



# Owner's Manual and Instructions

Premier Ductable Heaters

View this manual online at [www.lbwhite.com](http://www.lbwhite.com)



MODELS	OUTPUT (Btuh/kW)	FUEL
TS350	350,000/102.6	Propane Vapor Withdrawal or Natural Gas

Certification by:



## SCAN THIS QR CODE

with your smartphone or visit <http://goo.gl/nvneR> to view maintenance videos for L.B.White heaters.\*



\*Requires an app like QR Droid for Android or QR Reader for iPhone.

## Congratulations!

You have purchased the finest circulating construction heater available.

Your new L.B. White heater incorporates the benefits from the most experienced manufacturer of heating products using state-of-the-art technology.

We, at L.B. White, **thank you** for your confidence in our products and welcome any suggestions or comments you may have...contact us at 1-800-345-7200, or email us at [customerservice@lbwhite.com](mailto:customerservice@lbwhite.com).

### ATTENTION ALL USERS

This heater has been tested and evaluated by C.S.A. International in accordance with the requirements of Standard ANSI Z83.7 • CSA 2.14 and is listed and approved as a ductable direct gas-fired forced-air construction heater with application for the temporary heating of buildings under construction, alteration, or repair. If you are considering using this product for any application other than its intended use, then please contact your fuel gas supplier, or the L.B. White Co., Inc.



World Provider - Innovative Heating Solutions

411 Mason Street, Onalaska, WI 54650 ■ (800) 345 7200 ■ (608) 783 5691 ■ (608) 783 6115, fax ■ [www.lbwhite.com](http://www.lbwhite.com)



### GENERAL HAZARD WARNING

- Failure to comply with the precautions and instructions provided with this heater, can result in:
  - Death
  - Serious bodily injury or burns
  - Property damage or loss from fire or explosion
  - Asphyxiation due to lack of adequate air supply or carbon monoxide poisoning
  - Electrical shock
- Read this Owner's Manual before installing or using this product.
- Only properly-trained service people should repair or install this heater.
- Save this Owner's Manual for future use and reference.
- Owner's Manuals and replacement labels are available at no charge. See website, or for assistance, contact L.B. White at 1-800-345-7200.



### WARNING

- Proper gas supply pressure must be provided to the inlet of the heater.
- Refer to data plate for proper gas supply pressure.
- Gas pressure in excess of the maximum inlet pressure specified at the heater inlet can cause fires or explosions.
- Fires or explosions can lead to serious injury, death, or building damage.
- Gas pressure below the minimum inlet pressure specified at the heater inlet may cause improper combustion.
- Improper combustion can lead to asphyxiation or carbon monoxide poisoning and therefore serious injury or death.



### WARNING

#### Fire and Explosion Hazard

- Not for home or recreational vehicle use.
- Installation of this heater in a home or recreational vehicle may result in a fire or explosion.
- Fire or explosions can cause property damage or loss of life.



### WARNING

#### Fire and Explosion Hazard

- Keep solid combustibles a safe distance away from the heater.
- Solid combustibles include wood, paper, or plastic products, building materials and dust.
- Do not use the heater in spaces which contain or may contain volatile or airborne combustibles.
- Volatile or airborne combustibles include gasoline, solvents, paint thinner, dust particles or unknown chemicals.
- Failure to follow these instructions may result in a fire or explosion.
- Fire or explosions can lead to property damage, personal injury or loss of life.

### FOR YOUR SAFETY

If you smell gas:

1. Open windows.
2. Don't touch electrical switches.
3. Extinguish any open flame.
4. Immediately call your gas supplier.

### FOR YOUR SAFETY

Do not store or use gasoline or other flammable vapors and liquids in the vicinity of this or any other appliance.



<b>SECTION</b>	<b>PAGE</b>
General Information . . . . .	4
Heater Specifications . . . . .	4
Safety Precautions . . . . .	5
Installation Instructions	
General . . . . .	7
Gas Supply Sizing . . . . .	8
Connecting Hose to Heater . . . . .	8
Connecting Regulator to Gas Supply . . . . .	9
Installation of Heater . . . . .	10
Inside Structure . . . . .	10
Outside Structure (Using air distribution accessories) . . . . .	10
A. Extendable Duct . . . . .	10
B. End Diffuser . . . . .	11
Start-Up Instructions . . . . .	12
Shut-Down Instructions . . . . .	13
Gas Selector Valve . . . . .	13
Cleaning Instructions . . . . .	14
Maintenance Instructions . . . . .	14
Service Instructions	
General . . . . .	15
Belt Replacement . . . . .	15
Belt Tensioner . . . . .	16
Fan and Motor Pulley . . . . .	16
Drive Component Troubleshooting . . . . .	16
Fan Motor . . . . .	17
Air Proving Switch . . . . .	17
Igniter Assembly . . . . .	18
Testing the Manual Reset High Limit Switches . . . . .	19
Burner Orifice and Gas Control Valve . . . . .	19
Fan Wheel, Bearings, and Shaft . . . . .	20
Gas Pressure Checks . . . . .	21
Troubleshooting Information . . . . .	22
Electrical Connection and Ladder Diagram . . . . .	28
Heater Component Function . . . . .	29
Parts Identification	
Parts Schematic . . . . .	30
Parts List . . . . .	31 & 32
Warranty Policy . . . . .	33
Replacement Parts and Service . . . . .	33

## General Information

This Owner's Manual includes all options and accessories commonly used on this heater.

When calling for technical service assistance, or for other specific information, always have model number, configuration number and serial number available. This information is contained on the dataplate.

This manual will instruct you in the operation and care of your unit. Have your qualified installer review this manual with you so that you fully understand the heater and how it functions.

The gas supply line installation, installation of the heater, and repair and servicing of the heater requires continuing expert training and knowledge of gas heaters and should not be attempted by anyone who is not so qualified. See page 6 for definition of the necessary qualifications.

Contact your local L.B. White distributor or the L.B. White Co., Inc. for assistance, or if you have any questions about the use of the equipment or its application.

The L.B. White Co., Inc. has a policy of continuous product improvement. It reserves the right to change specifications and design without notice.

## Heater Specifications

SPECIFICATIONS		Model	
		TS350	
Fuel Type		Propane Gas	Natural Gas
Maximum Input (Btuh/kW)		350,000/102.6	
Inlet Gas Supply Pressure Acceptable at the Inlet of the Heater for Purpose of Input Adjustment (Inches W.C./kPa)	<b>MAX.</b>	13.5/3.36	
	<b>MIN.</b>	11.0/2.74	
Burner Manifold Pressure (Inches W.C./kPa)		5.2/1.30	5.3/1.32
Fuel Consumption Per Hour		16.2 lbs./7.34 kg	350 cu.ft./9.9 m <sup>3</sup>
Motor Characteristics		Ball Bearing 1 H.P./745.7 Watts, 1,725 RPM	
Blower Speed		915 RPM	
Electrical Supply (Volts/Hz/Phase)		115/60/1	
Amp Draw	<b>STARTING</b>	35.0	
	<b>CONTINUOUS OPERATION</b>	11.0	
Dimensions L x W x H (Inches/cm)		48 x 22.25 x 32.75/122 x 56.5 x 83.2	
Minimum Safe Distances From Nearest Combustible Materials (Feet/meters)	<b>TOP</b>	1/0.3	
	<b>SIDES</b>	1/0.3	
	<b>BACK</b>	1/0.3	
	<b>BLOWER OUTLET</b>	6/1.83	
<b>GAS SUPPLY</b>		Propane - U.S.: 6, Canada:3.05 Natural Gas - N/A	
Net Weight (lbs./kg)		295/133.8	
Shipping Weight (lbs./kg)		310/140.6	
Minimum Ambient Temperature in Which Heater May Be Used		- 20° F/-29°C	

# Safety Precautions

## **WARNING**

### **Asphyxiation Hazard**

- Do not use this heater for heating human living quarters, garages, workshops, or other such confined spaces.
- Do not use in unventilated areas.
- The flow of combustion and ventilation air must not be obstructed.
- Proper ventilation air must be provided to support the combustion air requirements of the heater being used.
- Lack of proper ventilation air will lead to improper combustion.
- Improper combustion can lead to carbon monoxide poisoning leading to serious injury or death. Symptoms of carbon monoxide poisoning can include headaches, dizziness and difficulty in breathing.
- Proper ventilation air for combustion must be provided in accordance with OSHA 29 CFR 1926.154, Temporary Heating Devices, ANSI A10.10, Safety Requirements for Temporary and Portable Space Heating Devices, or the Natural Gas and Propane Installation Code, CAN/CSA B149.1 as appropriate.

## **FUEL GAS ODOR**

Propane gas and natural gas have man-made odorants added specifically for detection of fuel gas leaks.

If a gas leak occurs, you should be able to smell the fuel gas.

**THAT'S YOUR SIGNAL TO GO INTO IMMEDIATE ACTION!**

- Do not take any action that could ignite the fuel gas. Do not operate any electrical switches. Do not pull any power supply or extension cords. Do not light matches or any other source of flame. Do not use your telephone.
- Get everyone out of the building and away from the area immediately.
- Close all propane gas tank or cylinder fuel supply valves, or the main fuel supply valve located at the meter if you use natural gas.
- Propane gas is heavier than air and may settle in low areas. When you have reason to suspect a propane leak, keep out of all low areas.
- Use your neighbor's phone and call your fuel gas supplier and your fire department. Do not re-enter the building or area.
- Stay out of the building and away from the area until declared safe by the firefighters and your fuel gas supplier.
- **FINALLY**, let the fuel gas service person and the firefighters check for escaped gas. Have them air out the building and area before you return. Properly trained service people must repair the leak, check for further leakages, and then relight the appliance for you.

## **ODOR FADING – NO ODOR DETECTED**

- Some people cannot smell well. Some people cannot smell the odor of the man-made chemical added to propane or natural gas. You must determine if you can smell the odorant in these fuel gases.
- Learn to recognize the odor of propane gas and natural gas. Local propane gas dealers will be more than happy to give you a scratch and sniff pamphlet. Use it to become familiar with the fuel gas odor.
- Smoking can decrease your ability to smell. Being around an odor for a period of time can affect your sensitivity to that particular odor.
- The odorant in propane gas and natural gas is colorless and the intensity of its odor can fade under some circumstances.
- If there is an underground leak, the movement of gas through the soil can filter the odorant.
- Propane gas odor may differ in intensity at different levels. Since propane gas is heavier than air, there may be more odor at lower levels.
- **Always be sensitive to the slightest gas odor.** If you continue to detect any gas odor, no matter how small, treat it as a serious leak. Immediately go into action as discussed previously.

## **ATTENTION – CRITICAL POINTS TO REMEMBER!**

- Propane gas has a distinctive odor. Learn to recognize these odors. (Reference Fuel Gas Odor and Odor Fading sections above.)
- If you have not been properly trained in repair and service of propane gas then do not attempt to light heater, perform service or repairs, or make any adjustments to the heater on the propane gas fuel system.
- Even if you are not properly trained in the service and repair of the heater, ALWAYS be consciously aware of the odors of propane gas and natural gas.
- A periodic sniff test around the heater or at the heater's joints; i.e. hose, connections, etc., is a good safety practice under any conditions. If you smell even a small amount of gas, CONTACT YOUR FUEL GAS SUPPLIER IMMEDIATELY. DO NOT WAIT!

1. Do not attempt to install, repair, or service this heater or the gas supply line unless you have continuing expert training and knowledge of gas heaters.

Qualifications for service and installation of this equipment are as follows:

- a. To be a qualified gas heater service person, you must have sufficient training and experience to handle all aspects of gas-fired heater installation, service and repair. This includes the task of installation, troubleshooting, replacement of defective parts and testing of the heater. You must be able to place the heater into a continuing safe and normal operating condition. You must completely familiarize yourself with each model heater by reading and complying with the safety instructions, labels, Owner's Manual, etc., that is provided with each heater.
  - b. To be a qualified gas installation person, you must have sufficient training and experience to handle all aspects of installing, repairing and altering gas lines, including selecting and installing the proper equipment, and selecting proper pipe and tank size to be used. This must be done in accordance with all local, state and national codes as well as the manufacturer's requirements.
  - c. In the Commonwealth of Massachusetts, this product must be installed by a gas fitter licensed in the Commonwealth of Massachusetts.
2. All installations and applications of L.B. White heaters must meet all relevant local, state and national codes. Included are L.P. gas, natural gas, electrical, and safety codes. Your local fuel gas supplier, a local licensed electrician, the local fire department or similar government agencies, or your insurance agent can help you determine code requirements.

Refer to the following:

U.S. Installations:

- ANSI/NFPA 58, latest edition, Standard for Storage and Handling of Liquefied Petroleum Gas and/or
- ANSI Z223.1/NFPA 54, National Fuel Gas Code
- ANSI/NFPA 70, National Electrical Code.

Canadian Installations:

- CSA B149.1 Natural Gas and Propane Gas Installation Code.
- CSA C22.1 Part 1 Standard Canadian Electrical Code, and CSA C22.2 No.3, Electrical Features of Fuel Burning Equipment.

3. We cannot anticipate every use which maybe made of our heaters. Check with the local fire safety authority if you have questions about applications.
4. Do not wash the interior of the heater. Use only compressed air, a soft brush or dry cloth to clean the interior of the heater and it's components.
5. For safety, this heater is equipped with manual reset high limit switches, an air-proving switch and a redundant gas control valve.

Never operate the heater with any safety device that has been bypassed. Do not operate this heater unless all of these features are fully functioning.

6. Do not locate fuel gas containers or fuel supply hoses within 20 ft./6.10 meters of the blower outlet of the heater.
7. Do not block air intakes or discharge outlets of the heater. Doing so may cause improper combustion or damage to heater components leading to property damage.
8. The hose assembly shall be visually inspected on a daily basis after heater relocation and when the heater is in use. If it is evident there is excessive abrasion or wear, or if the hose is cut, it must be replaced prior to the heater being put into operation. The hose assembly shall be protected from building materials, and contact with hot surfaces during use. The hose assembly shall be that specified by the manufacturer. See parts list.
9. This heater is equipped with a gas selector valve. The selector valve must be properly positioned for the gas supplied to the heater. Further information on this feature is provided on page 14 of this manual.
10. Check for gas leaks and proper function upon heater installation, when relocating, and after servicing. Refer to leak check instructions within installation section of this manual.
11. This heater should be inspected for proper operation by a qualified service person before each use and at least annually.
12. Always turn off the gas supply to the heater if the heater is not going to be used in the heating of the work space.
13. This heater is equipped with a three-prong (grounding) plug for your protection against shock hazard and must be plugged directly into a properly grounded three-prong receptacle. Failure to use a properly grounded receptacle can result in electrical shock, personal injury, or death.
14. If gas flow is interrupted and flame goes out, do not relight the heater until you are sure that all gas that may have accumulated has cleared away. In any event, do not relight the heater for at least 5 minutes.
15. The heater requires a minimum 500 gallon/1892 litre propane tank for proper gas supply pressure and operation. A larger tank may be required depending upon operating conditions at the site.
16. When the heater is to be stored indoors, the connection between the propane gas supply cylinder(s) and the heater must be disconnected and the cylinder(s) removed from the heater and stored in accordance with the Standard for the Storage and Handling of Liquefied Petroleum Gases, ANSI/NFPA 58 or Standard CSA B149.1 Natural Gas and Propane Installation Code as appropriate.
17. Propane gas supply containers have left handed threads. Always use the appropriate wrench to make a connection to tighten or loosen the pigtail connector's P.O.L. fitting at the container's gas supply valve.

### **WARNING**

#### **Fire and Explosion Hazard**

##### **Can cause property damage, severe injury or death**

- To avoid dangerous accumulation of fuel gas, turn off gas supply at the heater service valve before starting installation, and perform gas leak test after completion of installation.
- Do not force the gas control knob. Use only your hand to turn the gas control knob. Never use any tools. If the knob will not operate by normal hand pressure the gas control valve should be replaced by a qualified service technician. Force or attempted repair may result in fire or explosion.

### **WARNING**

#### **Fire and Explosion Hazard**

- Do not use open flame (matches, torches, candles, etc.) in checking for gas leaks.
- Use only approved leak detectors.
- Failure to follow this warning can lead to fires or explosions.
- Fires or explosions can lead to property damage, personal injury or death.

1. Read all safety precautions and follow L. B. White recommendations when installing this heater. If during the installation or relocating of heater, you suspect that a part is damaged or defective, call a qualified service agency for repair or replacement.
2. Make sure the heater is level and properly positioned before use. Observe and obey all minimum safe distances of the heater to the nearest combustible materials. Safe distances are given on the heater dataplate and on page 4 of this manual.
3. This heater may be installed either indoors or outdoors. For outdoor installations, only the following air distribution devices may be used:
  - 18 in./43.7 cm Dia. x 12 ft./3.66 m Duct: Part #22835
  - End Diffuser: Part #23189

#### **DO NOT USE ANY OTHER LENGTH OF DUCTWORK OR FIELD FABRICATED DUCT, TAPPS, STOVE PIPE, ETC. ON THIS HEATER.**

4. The heater's gas pressure regulator (with pressure relief valve) must be protected from adverse weather conditions (rain, ice, snow) as well as from building materials (tar, concrete, plaster, etc.) which can affect safe operation and could result in property damage or injury.
5. Heaters used in the vicinity of combustible tarpaulins, canvas, plastics, wind barriers, or similar coverings shall be located at least 10 ft./3.05 meters from the coverings. The coverings shall be securely fastened to prevent ignition or upsetting of the heater due to wind action on the covering or other material.
6. Check all connections for gas leaks using approved gas leak detectors. Gas leak testing is performed as follows:

- Check all pipe connections, hose connections, fittings and adapters upstream of the gas control with approved gas leak detectors.
- In the event a gas leak is detected, check the components involved for cleanliness and proper application of pipe compound before further tightening.
- Furthermore tighten the gas connections as necessary to stop the leak.
- After all connections are checked and any leaks are stopped, turn on the main burner.
- Stand clear while the main burner ignites to prevent injury caused from hidden leaks that could cause flashback.
- With the main burner in operation, check all connections, hose connections, fittings and joints as well as the gas control valve inlet and outlet connections with approved gas leak detectors.
- If a leak is detected, check the components involved for cleanliness in the thread areas and proper application of pipe compound before further tightening.
- Tighten the gas connection as necessary to stop the leak.
- If necessary, replace the parts or components involved if the leak cannot be stopped.
- Ensure all gas leaks have been identified and repaired before proceeding.

7. A qualified service agency must check for proper operating gas pressure upon installation of the heater.
8. Light according to instructions on heater or within owner's manual.
9. **The heater must have the proper regulator for the application. The gas pressure regulator supplied on this heater is approved for both propane and natural gas use.** Contact your gas supplier, or the L.B. White Co., Inc. if you have any questions.
10. This heater is configured for use for L.P. gas vapor withdrawal. Do not use the heater in an L.P. gas liquid withdrawal system or application. If you are in doubt, contact the L.B. White Co., Inc.

11. The heater must be installed so as not to interfere with or obstruct normal exits, emergency exits, doors and walkways.
12. Railing, fencing or suitable substitute materials must be used to keep the heating equipment from any people using and visiting the structure.
13. The heater shall be located so that rain, ice, or snow drainage from the structure does not affect equipment operation. If the heater is mounted outside, it must be mounted above any pooled or standing water. If the unit is to be located on the ground, a surrounding trench is recommended to drain any rain, ice or snow away from the unit.
14. The ground and surrounding terrain must be cleared of any combustible vegetation and other combustible materials when the heater is utilized outside.
15. Eventually, like all electrical/mechanical devices, the thermostat can fail. Thermostat failure may result in an underheating condition. The thermostat should be tested to make sure it turns the heater on and off within a temperature differential of  $\pm 3^{\circ}\text{F}$  ( $\pm 1.5^{\circ}\text{C}$ ).
16. Take time to understand how to operate and maintain the heater by using this Owner's Manual. Make sure you know how to shut off the gas supply to the building and also to the individual heater. Contact your fuel gas supplier if you have any questions.
17. Any defects found in performing any of the service or maintenance procedures must be eliminated and defective parts replaced immediately. The heater must be retested by properly qualified service personnel before placing the heater back into use.

## **GAS SUPPLY SIZING**

The vaporization of propane is affected by several factors: the surface area of the container, the liquid level of propane, temperature surrounding the container, and the relative humidity. All of these factors are specific to a site. Therefore, a degree of experience and judgement is required to select the proper propane supply.

Although experience is the best guide, the following recommendations can be used as a starting point. The table is based on experience in northern climates where cold weather and high humidity are prevalent in the winter. If more or less favorable conditions prevail at a specific site, adjustments can be made on the basis of experience.

### **Recommended Gas Supply**

<u>Propane Supply Tank:</u>	<u>Heater(s)/Container:</u>
500 gall./1892 litre	1
1000 gall./3784 litre	2

If more than one gas supply container is used per heater, the containers must be manifolded together to allow vapor withdrawal simultaneously from multiple containers. Manifold system shall be in accordance with NFPA 58 or CSA B149.1.

## **CONNECTING HOSE TO HEATER**

1. Thread swivel onto connector at gas inlet of heater. See Fig. 1. Tighten securely.
2. The hose may be coiled up and hung on the hose hanger, with the regulator stored within the regulator storage bracket.

**FIG. 1**

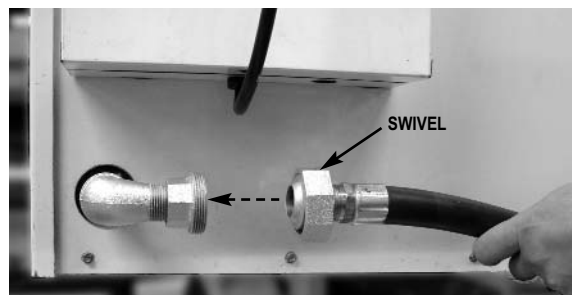



## CONNECTING REGULATOR TO GAS SUPPLY

### PROPANE HEATERS

1. Open the tank's cover.
2. Assemble bushing, pigtail connector and regulator as shown. Tighten connections securely. See Fig. 2.
3. Form the connector to ensure the regulator will be supported by the tank, and the tank valve cover will protect the regulator from weather conditions.

**FIG. 2**

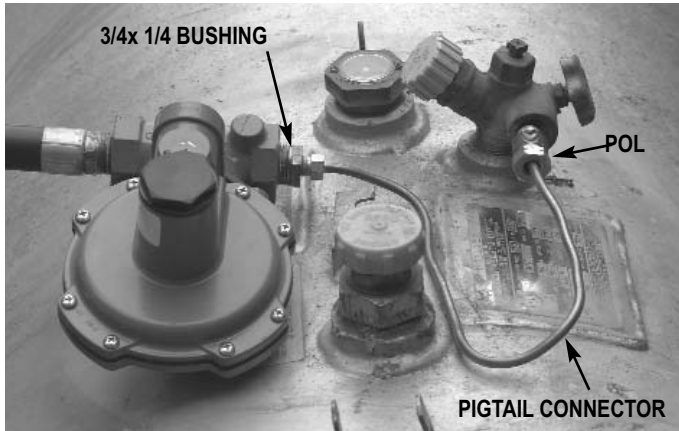

4. Thread connector's POL fitting counter-clockwise into the tank valve. Tighten securely. See Fig. 2.
5. Open the tank valve.
6. Check all connections with an approved leak detector. Close the tank's cover.
7. When storing or transporting the heater, ensure the connector's fitting is protected from damage and dirt entry.

### NATURAL GAS HEATERS

- The regulator only should be used if the supply pressure to the heater is above the maximum inlet pressure stated on the heater's dataplate.
- Connect the regulator to the natural gas supply line. Gas supply pressure to the regulator must be a minimum of 2 PSI/13.7 kPa.

# Installation of Heater

## INSIDE STRUCTURE

**FIG. 3**

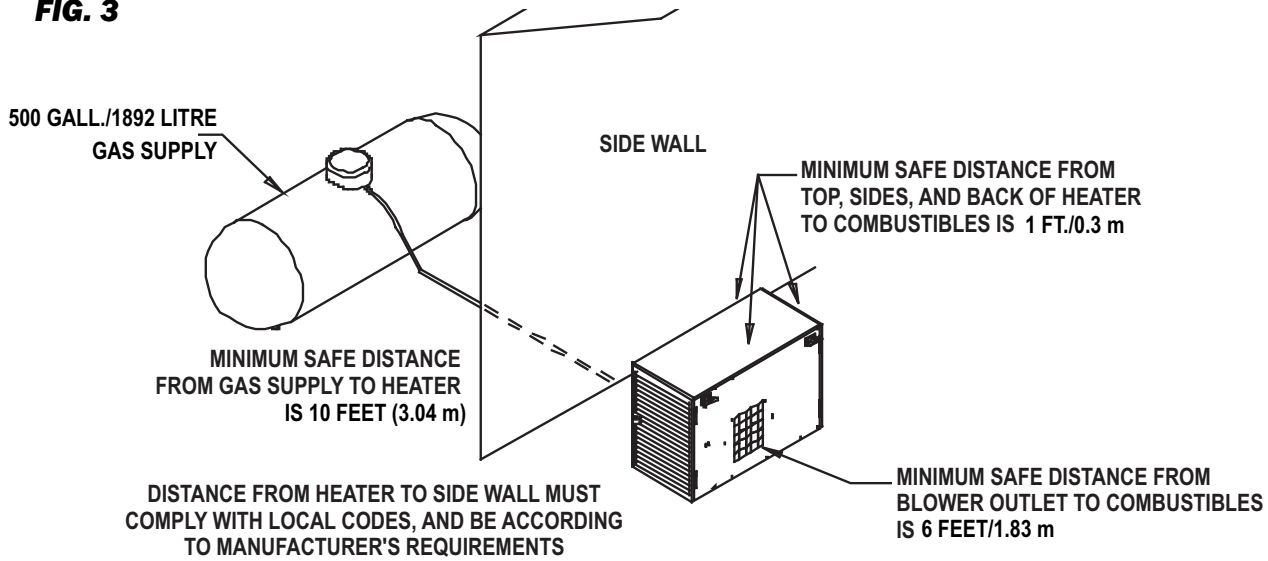

## OUTSIDE STRUCTURE

### (Air Distribution Accessories)

**A. Duct Kit**

Accessory # 22835

- 1.. Extend duct kit to 12 feet/3.6 meter length.
2. Mount duct to blower outlet of heater by inserting tabs on duct adapter into vertical and horizontal slots located at top and sides of blower outlet. See Fig. 4. Push down on duct adapter to secure adapter into slots. See below for for typical installation of heater located at exterior.

**FIG. 4**

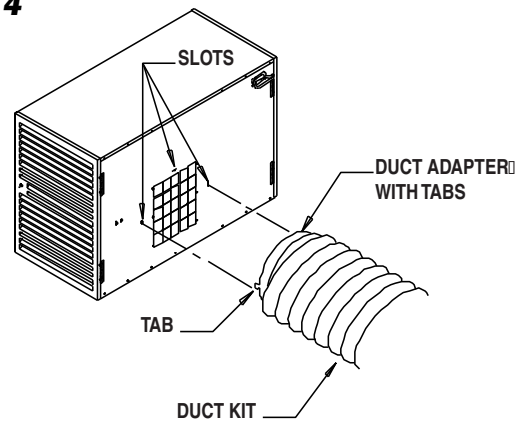

**FIG. 5**

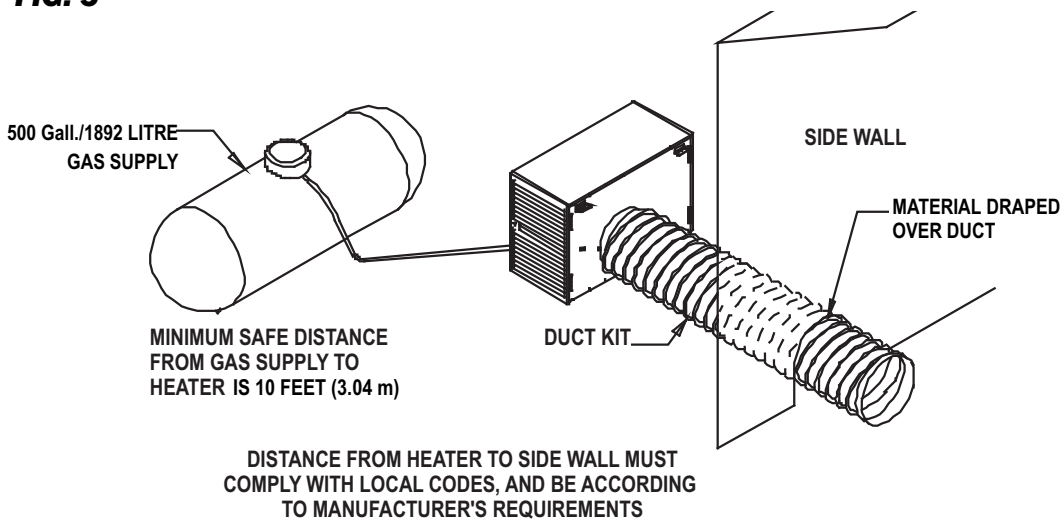

**B. Attaching End Diffuser to Duct**

Accessory # 23189

1. Loosen screw on duct clamp so clamp is easily positioned over ribs at end of flexible duct.
2. Slide duct adapter into duct end. Duct adapter tabs must be facing away from duct and are located at 3, 9 and 12 o'clock positions. See Fig. 6.
3. Tighten screw clamp so adapter is held securely within duct.
4. Insert tabs of adapter into slots on air diffuser back.
5. Push down on adapter so tabs are seated firmly to air diffuser.
6. Locate diffuser under side wall. See Fig. 7.

**FIG. 6**

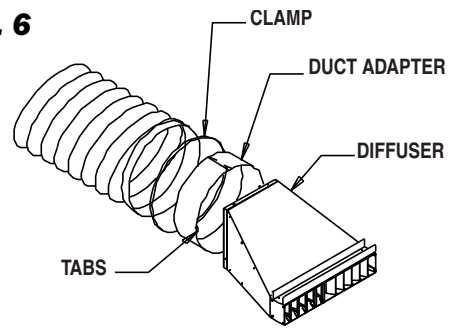

**FIG. 7**

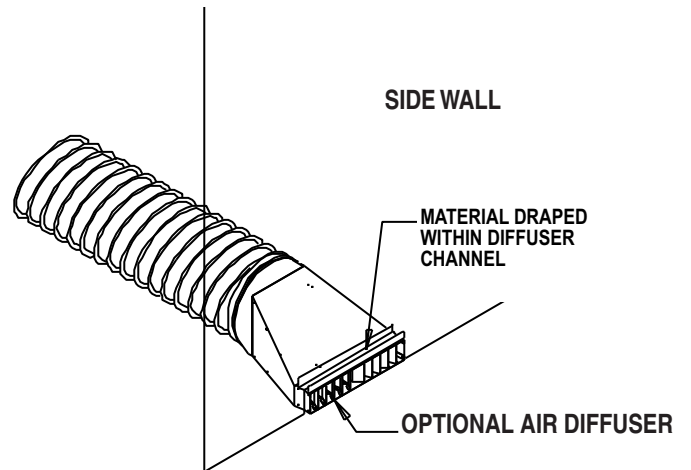

# Start-Up Instructions

For initial start-up after heater installation, follow steps 1-5. For normal start-up, set the thermostat above room temperature.

1. Connect electrical cord to an approved electrical outlet.
2. Set thermostat to desired room temperature.
3. A selector switch is located on the back of the heater. This switch allows you to either heat or ventilate (no heat). See Fig. 8 for selector switch positions.

**FIG. 8**



## A. Heating Mode Operation

- a. Open all manual fuel supply valves. Check for gas leaks using an approved leak detector. The gas control valve on the heater has a manual shut-off feature incorporated into the valve assembly. Ensure the indicator is turned to the on position. See Fig 9.

**FIG. 9**

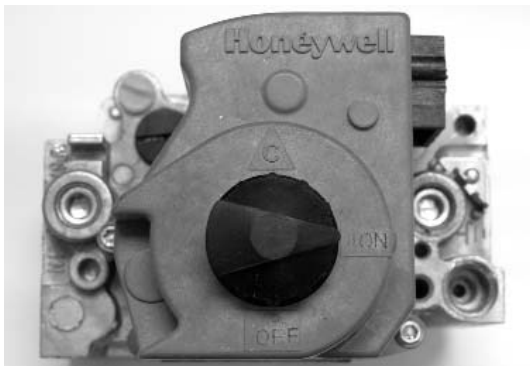

- b. Position the selector switch to heat.  See Fig. 8. A red light within the switch will come on. The fan motor will start, the igniter will spark and ignition will occur. The thermostat will cycle the heater on or off based upon temperature setting.

## B. Ventilation Mode Operation

When the selector switch is positioned to vent,  the red light will NOT be on. The fan motor will start, but the igniter will not spark, nor will ignition occur. This feature is used only when air circulation is required. The heater will not cycle on its thermostat setting. To discontinue the ventilation feature, position the switch to off or heat.

## C. Off

Position the switch to midpoint. 

## ATTENTION

- It is normal for air to be trapped in gas hose on new installations. The heater may attempt more than one trial for ignition before air is finally purged from line and ignition takes place.
4. The direct spark ignition (DSI) control board within this heater is self-diagnostic. The board works in conjunction with a light emitting diode (L.E.D.) built into the selector switch. The L.E.D. will flash a specific continuous flash pattern depending on a problem that occurs. Match specific flash pattern given by L.E.D. to troubleshooting label applied to inside of burner cap access panel of the heater. The troubleshooting label identifies the causes of the problem as it relates to specific flash pattern and remedies to correct the problem. See also "Troubleshooting Data" within this Owner's Manual.
  5. Do not exceed input rating stamped on nameplate or manufacturer's recommended burner orifice pressure for size orifice(s) used. Make certain that the primary air supply to main burner is open and free of dust, dirt and debris for complete, proper combustion.

## Shut-Down Instructions

If the heater is to be shut down for cleaning, maintenance, or repair, follow steps 1-5. Otherwise, set the thermostat to OFF or NO HEAT for standard shut-down.

1. Close the gas supply valve.
2. Allow the heater to burn off any fuel gas remaining in the gas supply line.
3. Set the thermostat to OFF or NO HEAT.

4. Position selector switch to off **O**
5. Disconnect the heater from its gas and electrical supplies.

**Note:** When the thermostat cycles the burner off, the fan motor will continue to run for 1minute, allowing the heat chamber to cool. After 1 minute, the fan motor will shut off.

## Gas Selector Valve

1. This feature allows the heater to operate on either propane or natural gas without changing out the burner orifice. The gas selector valve is located between the gas control valve and the burner. Gas selection is made by repositioning the valve's handle. THIS IS NOT A MANUAL GAS SHUT OFF VALVE.
2. Refer to Figs. 10 and 11. **The valve handle must be properly positioned for the specific gas being used.**
3. **The handle must be fully set at 90 degrees to gas flow (propane gas) or parallel to gas flow (natural gas) for proper operation.** Do not operate the heater with the valve handle set between either position, otherwise improper operation will occur.
4. The valve's handle can be locked to prevent improper positioning. Use the holes provided on the valve's body and handle. See Fig. 12.

**FIG. 10**

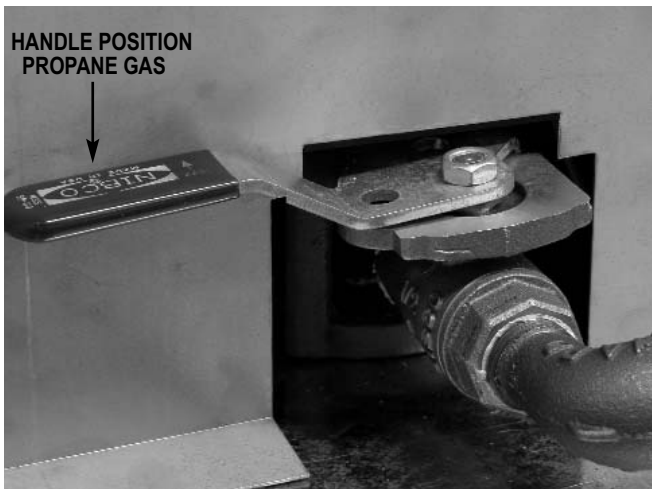

**FIG. 11**

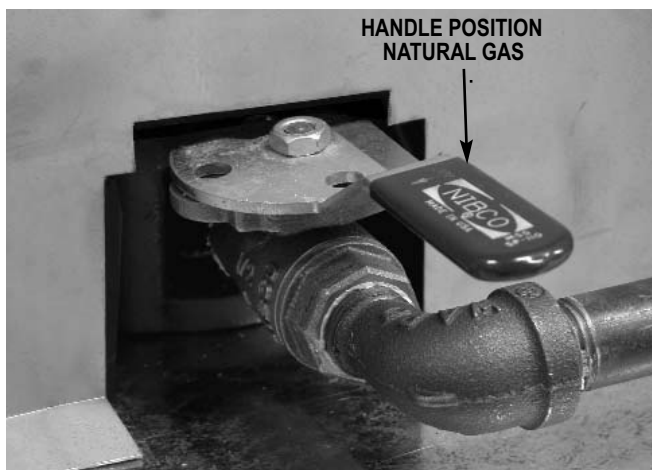

**FIG. 12**



## Cleaning Instructions



### WARNING

#### Fire, Burn, and Explosion Hazard

- This heater contains electrical and mechanical components in the gas management, and safety systems.
- Such components may become inoperative or fail due to dust, dirt, wear and aging.
- Periodic cleaning and inspection as well as proper maintenance are essential to avoid serious injury or property damage.

1. Before cleaning, shut off all gas supply valves and disconnect electrical supply.
2. The heater should have dirt or dust removed periodically:
  - a. Before each use give the heater a general cleaning using compressed air or a soft brush or dry rag on its case and internal components. At this time, dust off the motor case to prevent the motor from over-heating.
  - b. At least once a year, give the heater a thorough cleaning. At this time, remove the fan and motor assembly and brush or blow off the fan blade assembly. Additionally, make sure the burner air inlet venturi ports and the casting are free of dust accumulation.



### WARNING

Do not use a pressure washer, water, or liquid cleaning solution on any gas controls. Use of a pressure washer, water, or liquid cleaning solution on the control components can cause severe personal injury or property damage due to water and/or liquids:

- In electrical components, and wires causing electrical shock or equipment failure.
- On gas control valves causing corrosion which can result in gas leaks and fire or explosion from the leak.

Clean all components of the heater with pressurized air, a dry brush, or a dry cloth.

## Maintenance Instructions

1. The area surrounding the heater shall be kept clear and free from combustible materials, gasoline, and other flammable vapors and liquids.
2. Have your gas supplier check all gas piping annually for leaks or restrictions in gas lines.
3. Regulators must be periodically inspected to make sure the regulator vents are not blocked. Debris, insects, insect nests, snow, or ice on a regulator can block vents and cause excess pressure at the heater.
4. Regulators can wear out and function improperly. Have your gas supplier check the date codes on all regulators installed and check delivery pressures to the heater to make sure that the regulator is reliable.
5. Check all wiring associated terminals and electrical components within the heater for corrosion, frayed or cut insulation, tight connections, etc. Repair or replace as necessary.
6. Review all heater markings (i.e. wiring diagram,

warnings, start-up, shut-down, troubleshooting, etc.) at the time of maintenance for legibility. Make sure none are cut, torn, or otherwise damaged. Any damaged markings must be replaced immediately by contacting the L.B. White Co., Inc. Dataplates, start-up and shut-down instructions and warnings are available at no cost. A nominal charge will be applied for wiring diagrams.

7. Check the heater's fan drive belt. Make sure the belt is not cracked. If so, replace it. Additionally, ensure the belt is not slipping, that belt tension is proper and sheaves are properly aligned and not worn. These procedures should be done whenever the heater is being readied for use.
8. Lubricate the bearings once a month. Use NLGI grade 2 mineral oil lithium or lithium base grease.

**WARNING**  
**Burn Hazard**

- Heater surfaces are hot for a period of time after the heater has been shut down.
- Allow the heater to cool before performing service, maintenance, or cleaning.
- Failure to follow this warning will result in burns causing injury.

**WARNING**  
**Fire and Explosion Hazard**

- Do not disassemble or attempt to repair any heater components or gas train components.
- All component parts must be replaced if defects are found.
- Failure to follow this warning will result in fire or explosions, causing property damage, injury, or death.

1. Close the fuel supply valve to the heater and disconnect the electrical supply before servicing unless necessary for your service procedure.
2. Clean the heater's orifice with compressed air or a soft, dry rag. Do not use files, drills, broaches, etc. to clean the orifice hole. Doing so will enlarge the hole, causing combustion or ignition problems. Replace the orifice if it cannot be cleaned properly.
3. The high limit switches, HEAT/VENT switch, and

thermostat can be tested by disconnecting the leads at the component, and jumpering the leads together.:

- Reconnect the electrical supply and open fuel supply valves.
  - If the heater lights, the component is defective and must be replaced.
  - Do not leave the jumper on or operate the heater if the part is defective. Replace the part immediately.
  - An alternate method for checking the components is to perform a continuity check..
4. The air proving switch must not be jumpered. If jumpered, the ignition control will not allow heater operation. Test the air proving switch for continuity. If defective, replace the switch
  5. Open the respective case panel for access to burner or fan related components.
  6. For reassembly, reverse the respective service procedure. Ensure gas connections are tightened securely.
  7. After servicing, start the heater to ensure proper operation and check for gas leaks.
  8. If pulley or fan keys are lost during service, replacements are made by using 4.7 mm. square x 2.54 cm. bar stock. Otherwise, order Part #22955.

## BELT REPLACEMENT

1. Remove belt guard from heater.
2. Push the belt tensioner clockwise for removal of the belt . See Fig. 13.

**FIG. 13**

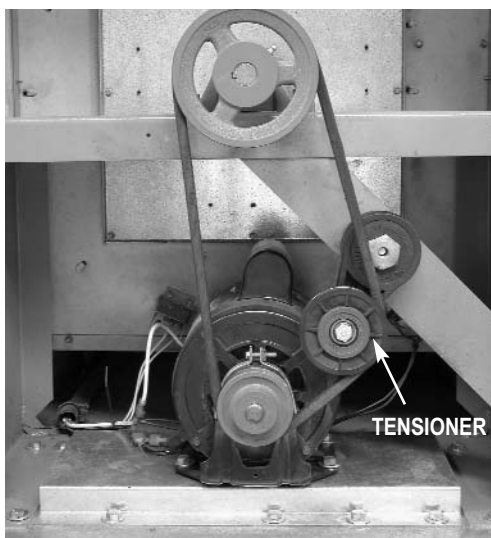

3

Check the fan and motor grooves for dirt. Clean the pulleys if needed.

4. Install new belt. Using a straight edge, check motor and fan pulley alignment. Contact must be made at edges of both pulleys. See Fig. 14.

**FIG. 14**

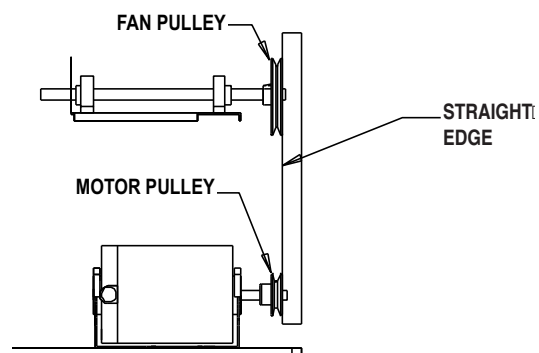

## BELT TENSIONER

1. The tensioner automatically applies proper tightness to the belt during operation, and eliminates the need for manually retensioning the belt after service.
2. When replacing the belt, and during routine maintenance, ensure tensioner is positioned as shown in Fig.15 after belt removal.

**FIG. 15**

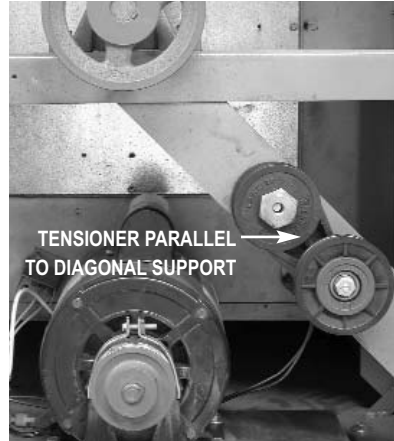

## FAN AND MOTOR PULLEYS

1. Remove belt guard from heater.
2. Remove belt from pulleys. See Belt Replacement.
3. Loosen set screw on fan and motor pulleys. See Fig. 16 for typical set screw location.
4. Remove pulleys and keys from fan shaft and motor.

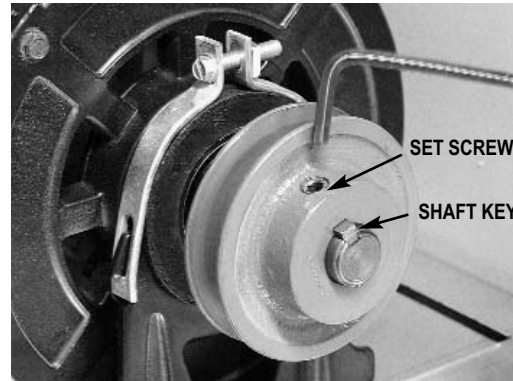

**FIG. 16**

## FAN DRIVE COMPONENTS TROUBLESHOOTING

Refer to the following table to identify basic problems, causes and cures associated with V-Belt drive systems.

<u>PROBLEM</u>	<u>CAUSE</u>	<u>CURE</u>	<u>PROBLEM</u>	<u>CAUSE</u>	<u>CURE</u>
<b>Belt slips</b>	Pulleys worn (Belts bottoming out in grooves)	Replace pulleys	<b>Belt Jumps Pulley Grooves</b>	Drive misaligned	Check and realign
	Oil or grease on belt	Clean pulley or belt.		Dirt entering pulley	Remove belt, clean the pulleys
<b>Belt Breaks</b>	Improper belt installation	Belt pried over pulleys using sharp or pointed tools. Install new belt properly.	<b>Belt Cracking</b>	Belt hitting belt guard	Realign guard (check for loose or missing guard screws)
	Improper belt tension.	Ensure belt tensioner is positioned properly.		Dirt or grease on belt or aged belt	Remove dirt or replace belt.
			<b>Belt wearing rapidly</b>	Belt hitting belt guard	Realign guard (check for loose or missing guard screws)
				Worn pulley	Replace pulley
				Dirt in pulleys	Remove dirt



---

## FAN MOTOR

1. Remove belt guard from heater.
2. Remove fan belt.
3. Remove motor pulley from motor and mounting hardware. See Fig. 17.

**FIG. 17**

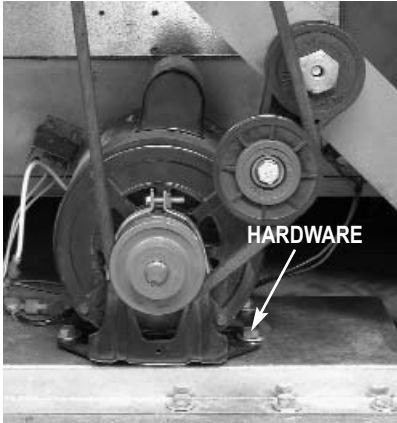

4. Open electrical supply access panel on motor and disconnect power supply wiring. See Fig. 18.

**FIG. 18**



- Ensure motor and fan pulleys are properly aligned before tightening pulleys to motor shaft.
- Refer to alignment procedures within manual
- Motor bearings are permanently lubricated.

---

## AIR PROVING SWITCH

1. Remove the screws and turn switch assembly so the paddle on the switch arm can be pulled through oblong hole on side of fan housing. See Fig. 19.
2. Disconnect the leads from the air proving switch.

**FIG. 19**

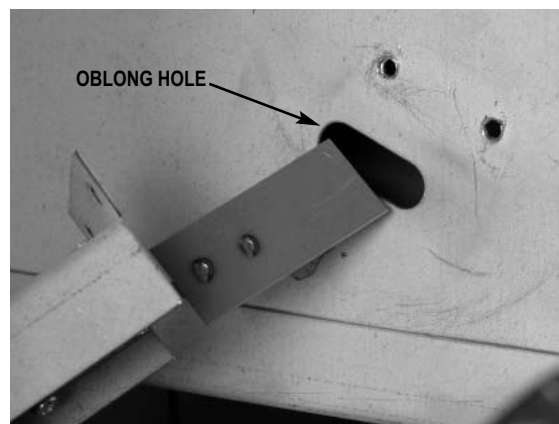

# IGNITER ASSEMBLY

1. Remove burner access panel. See Fig. 20.

**FIG. 20**

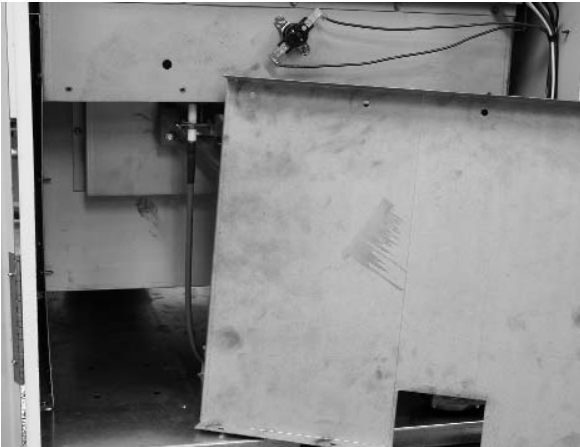

2. The igniter assembly is located at the top of the burner casting. Remove the two screws securing the mounting bracket to the burner. See Fig. 21.

**FIG. 21**

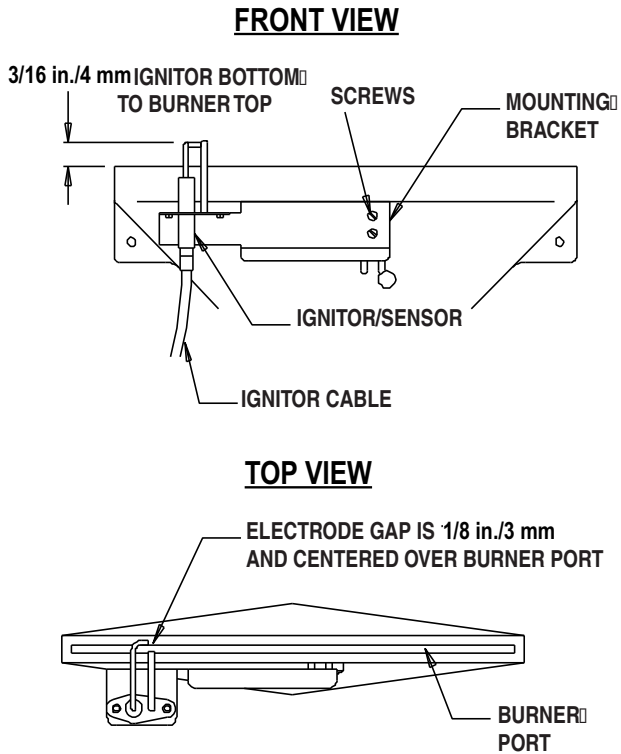

3. Disconnect high voltage ignition lead. Remove the screws. See Fig. 22.

**FIG. 22**

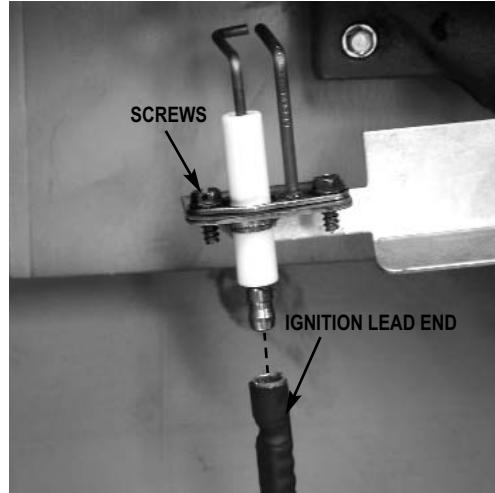

- The igniter and ground rod should be cleaned during routine maintenance to maintain proper ignition.
  - Use steel wool or emery cloth.
  - Rub briskly to remove buildup of dust, dirt, and oxide.
- Check the igniter's ceramic base for cracks.
  - Replace the igniter if cracks are found.

## TESTING THE MANUAL RESET HIGH LIMIT SWITCHES

### **WARNING** Fire Hazard

- Do not operate the heater with the high limit switch bypassed.
- Operating the heater bypassed high limit switch may lead to overheating, possibly resulting in a fire, with subsequent damage to the heater or property damage.

This heater has two limit switches. One is located at the burner end of the heater. The other is located on the fan housing at the motor end of the heater. Their purpose is to safely shut the heater down if the appliance should overheat.

Both high limit switches should be tested a minimum of once per year when the heater is given a thorough cleaning.

1. Remove the high limit switches.
2. Holding a switch by one of its mounting legs, apply a small flame only to the sensing portion on the back of the switch. See Fig. 23. **Be careful not to melt the plastic housing of the switch when conducting this test.**

3. Within a minute, you should hear a pop coming from the switch, which indicates the contacts of the switch have opened.
4. Allow the switch to cool for about a minute before firmly pressing its reset button. The switch may have a red cap over the button. If you removed the cap to reset the switch, ensure you put it back on.
5. Check for electrical continuity across the switch terminals to make sure the contacts have closed.

**FIG. 23**

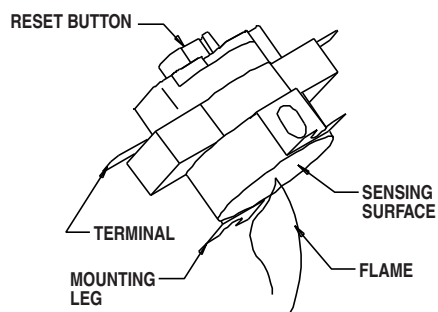

## BURNER ORIFICE AND GAS CONTROL VALVE

1. Remove hose and pipe nipple from control valve inlet.
2. Open burner end door.
3. Remove screws from gas control bracket and disconnect control valve's electrical wiring. See Fig. 24.
5. Remove burner retaining bolt from under base at gas control end of heater. See Fig. 26.

**FIG. 24**



4. Remove burner access panel. See Fig. 25.

**FIG. 25**



**FIG. 26**

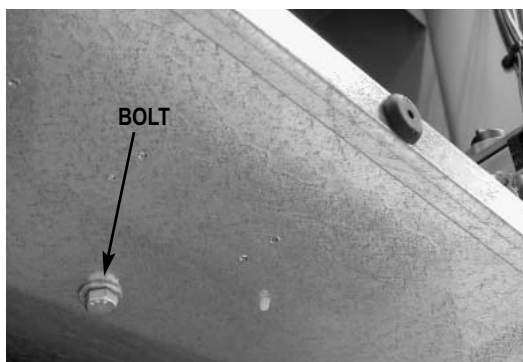

6. Lift and pivot the gas train assembly so orifice is exposed. See Fig. 27. Remove control valve or orifice as needed.

**FIG. 27**



# FAN WHEEL, BEARINGS, AND SHAFT

1. Remove the two lower case screws from both case sides. See Fig.28.
2. Spread the sides slightly so drive assembly with fan can be slid from heater.
3. Refer to the Figs. 29 & 30 for servicing of fan wheel, bearings, or shaft.

**FIG. 28**

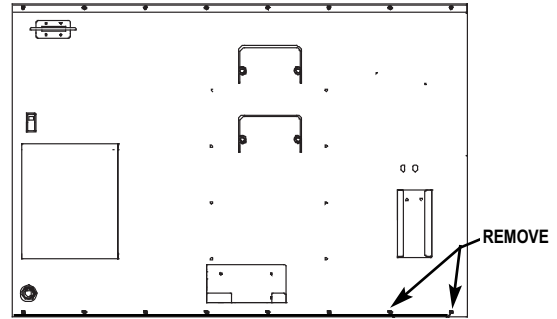

**FIG. 29**

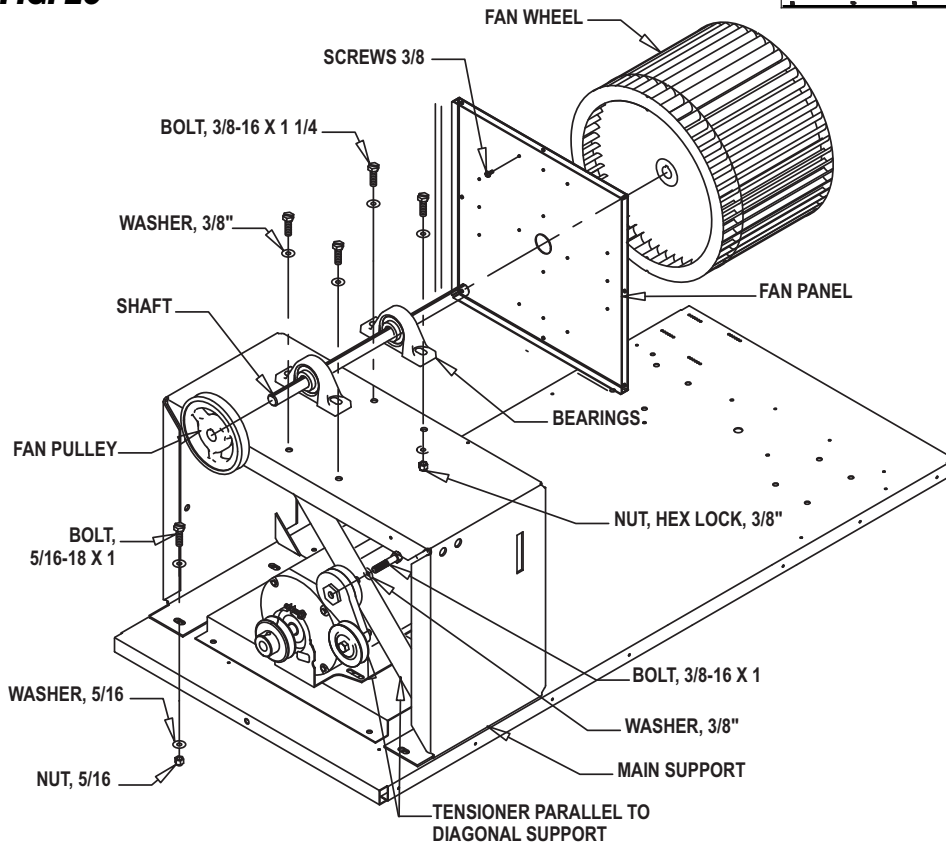

**FIG. 30**

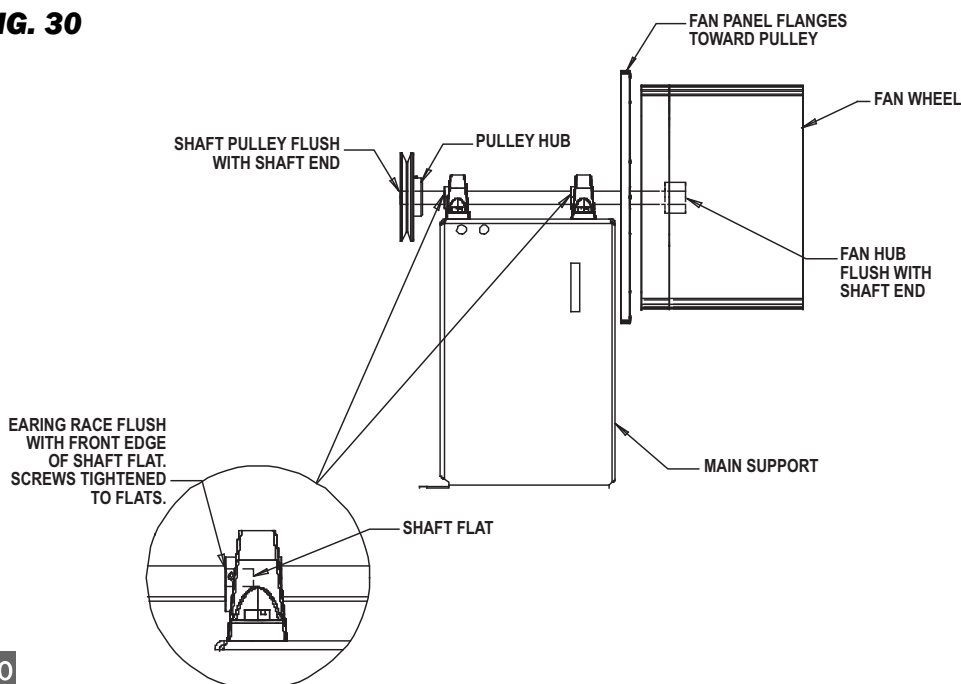

# Gas Pressure Checks

## WARNING

- Do not disassemble the gas control valve.
- Do not attempt to replace any components of the gas control valve.
- The gas control valve must be replaced if any physical damage occurs to the control valve assembly.
- Failure to follow this warning will result in fire or explosions, leading to injury or death to humans, and property damage.

## ATTENTION

- The following explains a typical procedure to be followed in checking gas pressures.
- The gas pressures will vary depending upon fuel type.
- Consult the dataplate on the heater or page 4 in this manual for specific pressures to be used in conjunction with this procedure.
- Gas pressure measured at the inlet to the gas valve is Inlet Pressure and gas pressure measured at the outlet of the gas valve is Burner Manifold Pressure.

## MATERIALS REQUIRED

(To be secured through local purchase)

Quantity	Description
2	Gas pressure gauges capable of reading up to 35 in.W.C./8.7 kPa

### A. Preparation

1. Disconnect the heater from the electrical supply and close the fuel supply valve to the heater.
2. Open the case access panel at burner end of heater.
3. Brush or blow off any dust or dirt in the vicinity of the gas control valve.

### B. Gauge Installation

1. Locate the gas control pressure taps. See Fig. 31. Remove the pressure tap plugs using an allen key.
2. Securely connect pressure gauges at these points.
3. Open the fuel supply valves to the heater and reconnect the heater electrical supply.
4. Start the heater

### C. Reading Pressures

1. With the heater operating, the pressure gauges should read the pressures specified on the dataplate.
2. Do the readings at the inlet and outlet pressure gauges agree with that specified on the dataplate? If so, then no further checking or adjustment is required. Proceed to section D.
3. If the inlet pressures do not agree with that specified on the dataplate, then the regulator controlling gas pressure to the heater requires adjustment.
  - Remove the regulator cap on the control valve.
  - Using a standard screwdriver turn the adjusting screw clockwise (to increase pressure) or counter-clockwise (to decrease pressure) until the burner manifold pressure is set.
  - Install regulator cap.
4. If the inlet pressure is correct but the burner manifold pressure does not agree with that specified on the dataplate, then the gas control valve's internal pressure regulator needs adjustment:
  - Remove the regulator cap on the control valve.
  - Using a standard screwdriver turn the adjusting screw clockwise (to increase pressure) or counter-clockwise (to decrease pressure) until the burner manifold pressure is set.
  - Install regulator cap.

### D. Completion

1. Once the proper inlet and burner manifold pressures have been confirmed and/or properly set, close the fuel supply valve to the heater and allow the heater to burn off any gas remaining in the gas supply line.
2. Disconnect the heater from its electrical supply and close fuel supply valve.
3. Remove the gauges.
4. Install pressure tap plugs.
5. Open fuel supply valve and reconnect electrical supply to heater. Start the heater and check for gas leaks.
6. Set thermostat to desired temperature.

**FIG. 31**

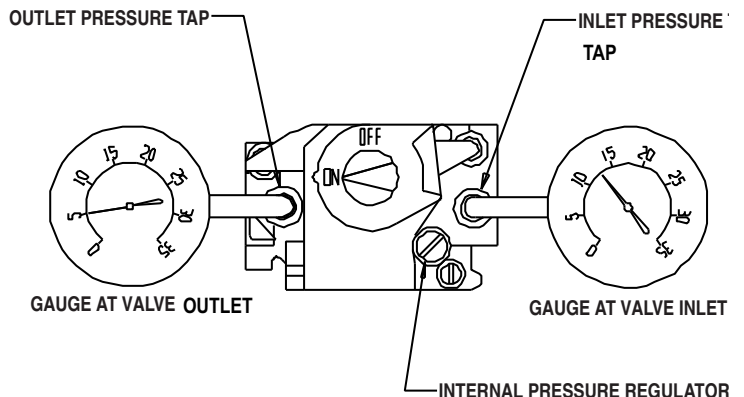

# Troubleshooting Information

**READ THIS ENTIRE SECTION BEFORE BEGINNING TO TROUBLESHOOT PROBLEMS.**

## **WARNING**

- This heater can start at any time.
- Troubleshooting this system may require operating the unit with line voltage present and gas on. Use extreme caution when working on the heater.
- Failure to follow this warning may result in property damage, personal injury or death.

The following troubleshooting guide provides systematic procedures for isolating equipment problems. This guide is intended for use by a **QUALIFIED GAS HEATER SERVICE PERSON. DO NOT ATTEMPT TO SERVICE THESE HEATERS UNLESS YOU HAVE BEEN PROPERLY TRAINED.**

### TEST EQUIPMENT REQUIRED

The following pieces of test equipment will be required to troubleshoot this system with minimal time and effort.

- **Digital Multimeter** - for measuring AC voltage and resistance.
  - **Low Pressure Gauge** - for checking inlet and outlet pressures at the gas control valve against dataplate rating.
- Visually inspect equipment for apparent damage.
  - Check all wiring for loose connections and worn insulation.

Refer to the system operation sequence in this section to gain an understanding as to how the equipment operates during a call for heat. Understanding the sequence of operation of the ignition module and related components is essential as it will relate directly to problem solving provided by the flow charts.

The ignition control module is self-diagnostic. The red light, located within the selector switch, will flash a specific light pattern depending upon the problem which is diagnosed. To effectively use the flow charts, you must first identify what the problem is by the light pattern of the L.E.D. (light emitting diode) diagnostic light. If the light is flashing, the flash pattern will be followed by a pause and then a repeat of the flash pattern until the problem is corrected. Refer to the tables below to identify what page to refer to when troubleshooting any problems.

The L.E.D. light will only be on when the selector switch is positioned to HEAT and the thermostat is set above room temperature. The light will not be on when the selector switch is positioned to VENT.

<b>Heating Mode Problems</b>	<b>Page</b>
L.E.D. is steady on. No flash pattern. ....	23
L.E.D. light is not on. ....	23

<b>Heating Mode Problems (Cont.)</b>	<b>Page</b>
L.E.D. diagnostic light is flashing:	
A. One Time .....	24
B. Two Times .....	25
C. Three Times .....	26
D. Four Times .....	26
E. Five Times .....	26

<b>Ventilation Mode Problems</b>	<b>Page</b>
A. Motor Does Not Run. ....	27
B. Motor "Hums," Does Not Run .....	27
C. Motor Runs with Low Air Output. ....	27

Components should be replaced only after each step has been completed and replacement is suggested in the flow chart. Refer to the Servicing sections as necessary to obtain information on disassembly and replacement procedures of the component once the problem is identified by the flow chart.

### **DIRECT IGNITION OPERATION SEQUENCE:**

- Selector switch is set to heat.
- Line voltage is sent to ignition control and to transformer.
- Red light on selector switch is illuminated.
- Transformer reduces line voltage to 24 volts which is sent to thermostat.
- The thermostat calls for heat.
- The thermostat sends 24 volts to ignition control.
- Ignition control module performs self safety check.
  - Internal components are tested.
  - Air proving circuit is checked.
- Ignition control module begins ignition trial sequence.
- Ignition control module sends 24 volts to air proving switch.
- Ignition control sends line voltage to motor relay
- Motor relay closes and fan motor starts.
- Air proving switch closes and 24 volts are returned to the ignition control module.
- Ignition control module sends high voltage to the igniter . electrode.
  - Igniter sparks.
- Ignition control module sends 24 volts to the gas control valve through the high limit switches.
  - Gas control valve opens.
- Ignition occurs.
  - Igniter continues to spark until flame proving occurs.
  - Ignition spark is cut off.
  - Gas valve stays open.
  - Gas control modulates based upon thermostat.
- Room warms to desired temperature.
  - Thermostat is satisfied.
  - Gas control closes, burner shuts down.
  - **Fan motor continues to run for 1 minute , cooling the heat chamber.**
  - Fan motor stops.
  - Heater shuts off.
- Process starts again on a call for heat.

### **IGNITION FAILURE SEQUENCE:**

- Trial for ignition takes approximately 10 seconds.
- If ignition module does not sense a flame within the ignition trial, the module goes into safety lockout (3 flash pattern.)
  - Gas valve closes.
  - Ignition spark shuts off.
  - Fan motor stops.
- To retry for ignition, the systems must be reset:
  - Turn the thermostat down and then up to call for heat or unplug heater and plug it back in or
  - Position selector switch to off and then back to on.

# HEATING MODE

LED Constant On → Normal Operation

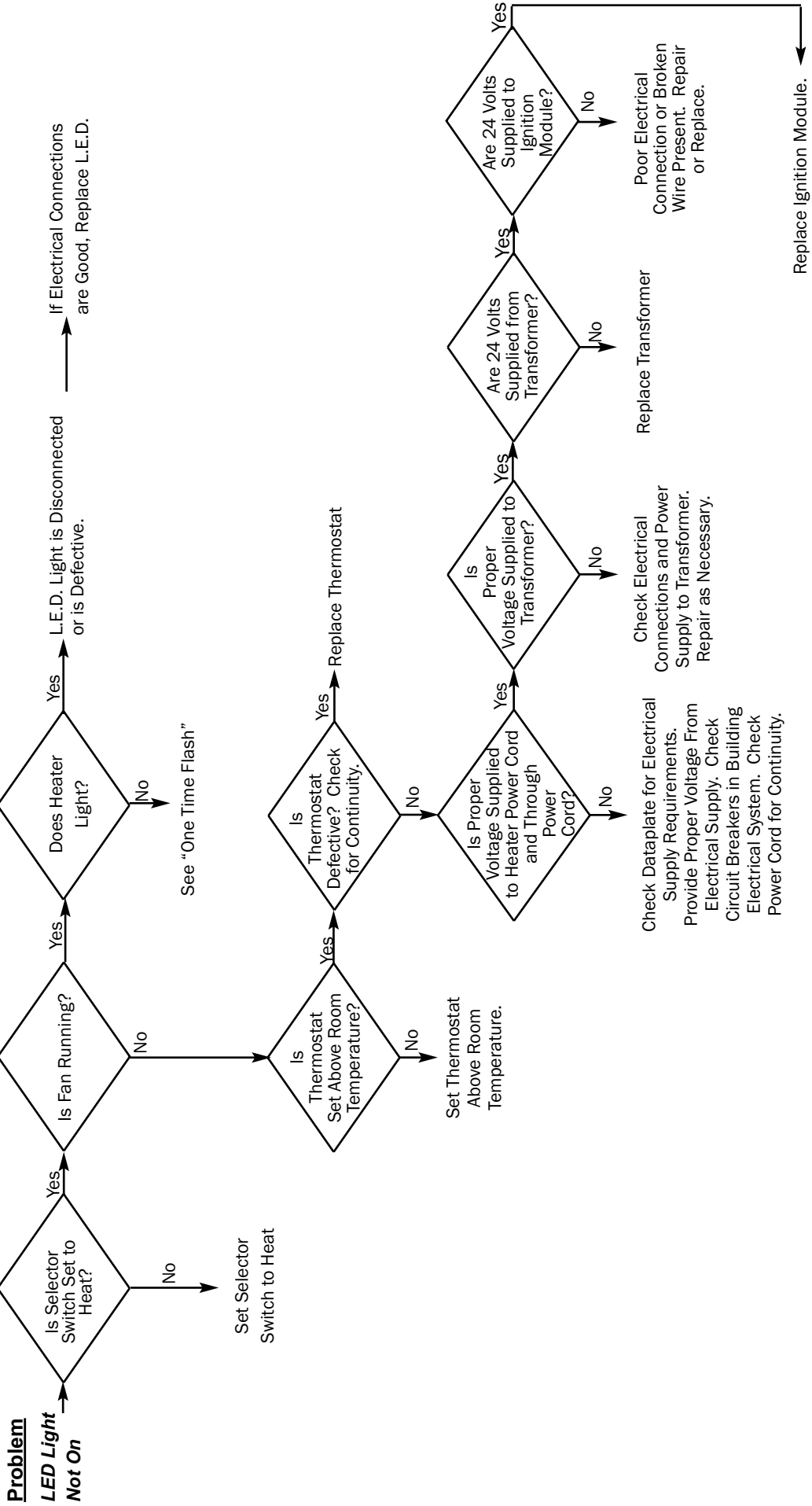

**Problem**

**LED Flashing**

**One Time  
Air proving Switch  
Contacts Are Closed  
before Fan Motor  
Starts.  
Pattern Begins 5  
Seconds After  
Condition  
Occurs.**

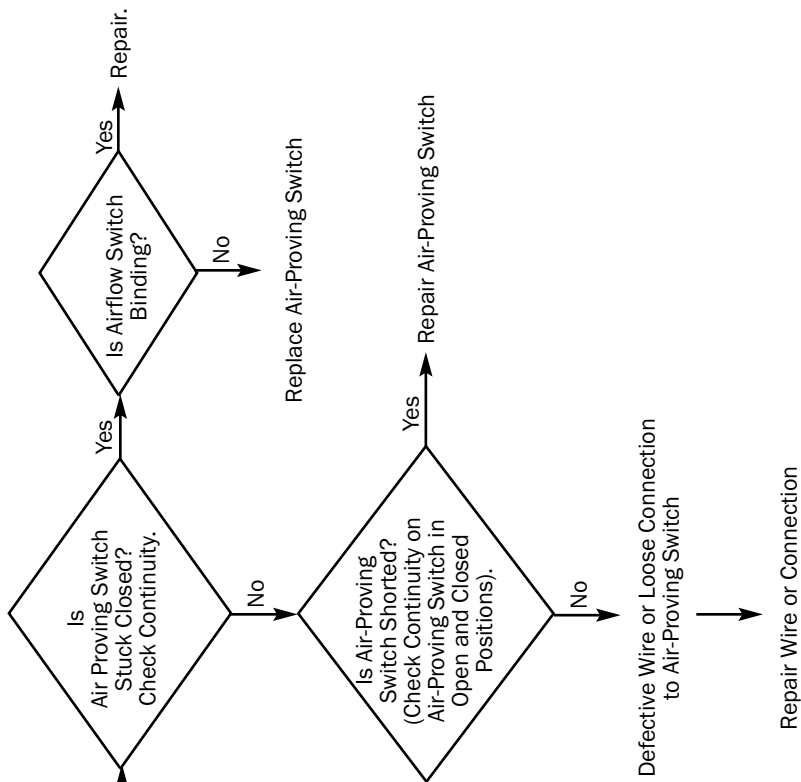



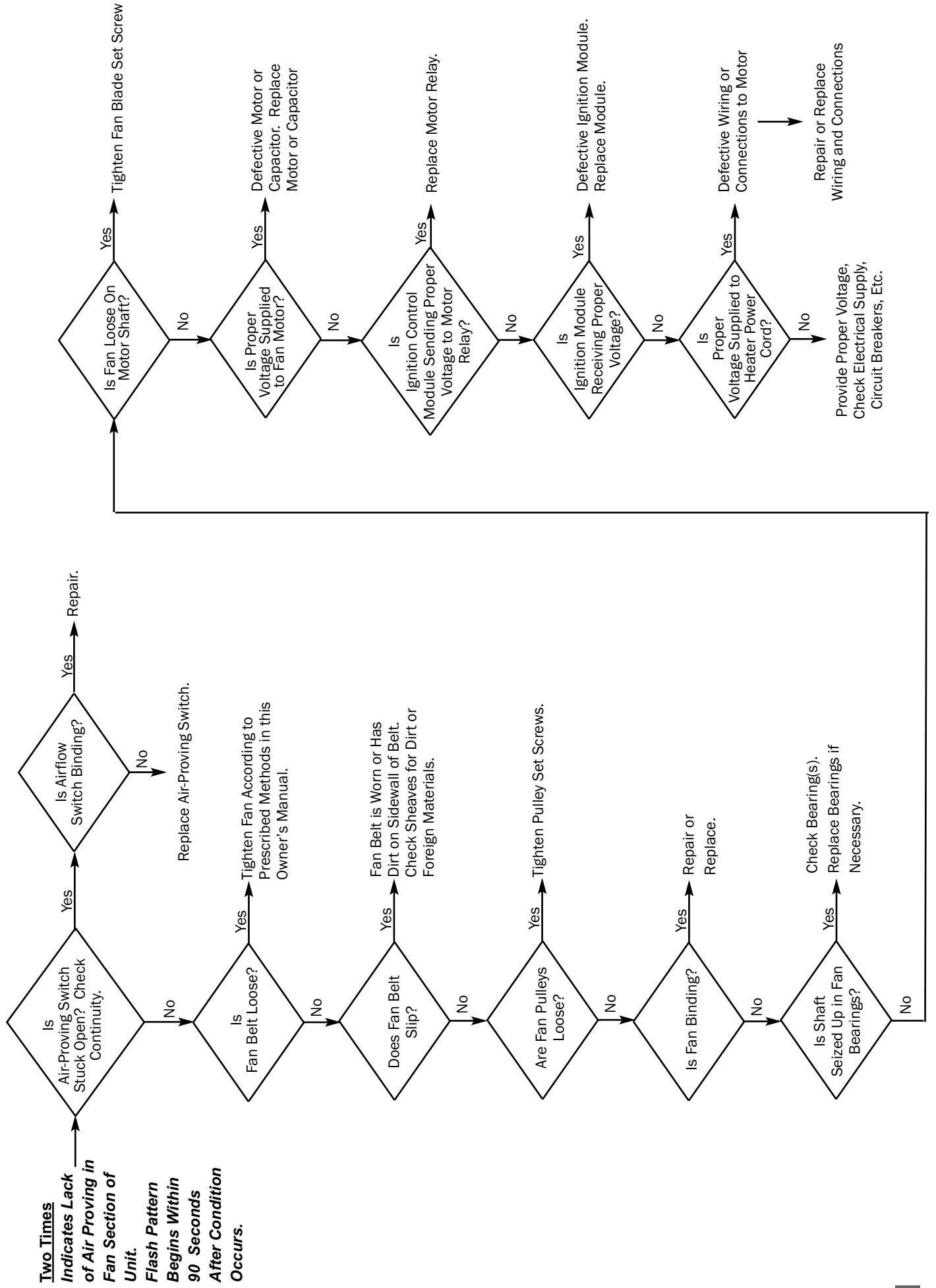

**Three Times**

**Indicates Burner Failure. The Control Module Has Gone into Safety Lockout. Flash Pattern Begins Within 30 Seconds After Condition Occurs.**

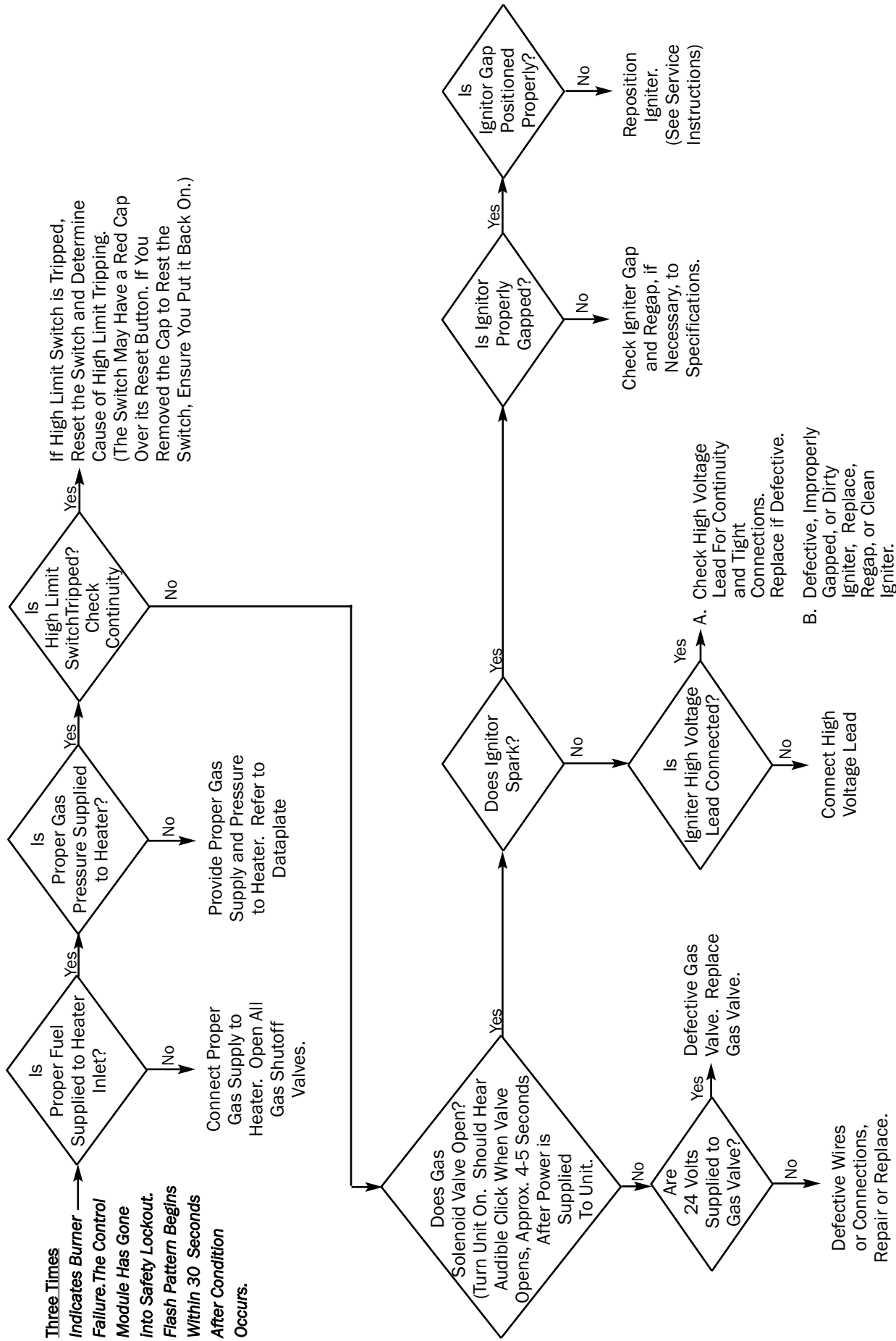

**Four Times**

**Lock Out From Flame Sense Loss** → Flame sense related problems. Check for cracked or dirty flame sensor, improperly positioned sensor, or poor flame sense ground.

**Five Times** → If control module does not reset, then replace the it (Internal board fault.) if module resets, then have qualified electrician check power source for power quality problems. (Frequency, line noise, line spikes, loose connections, too small wire gauge.)

# VENTILATION MODE

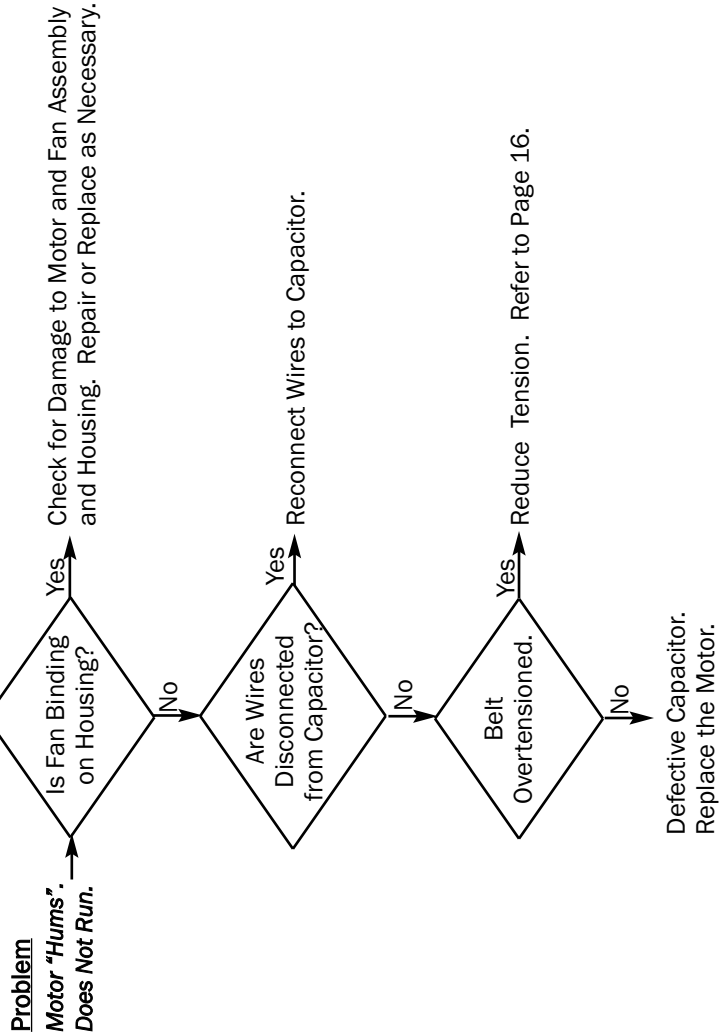
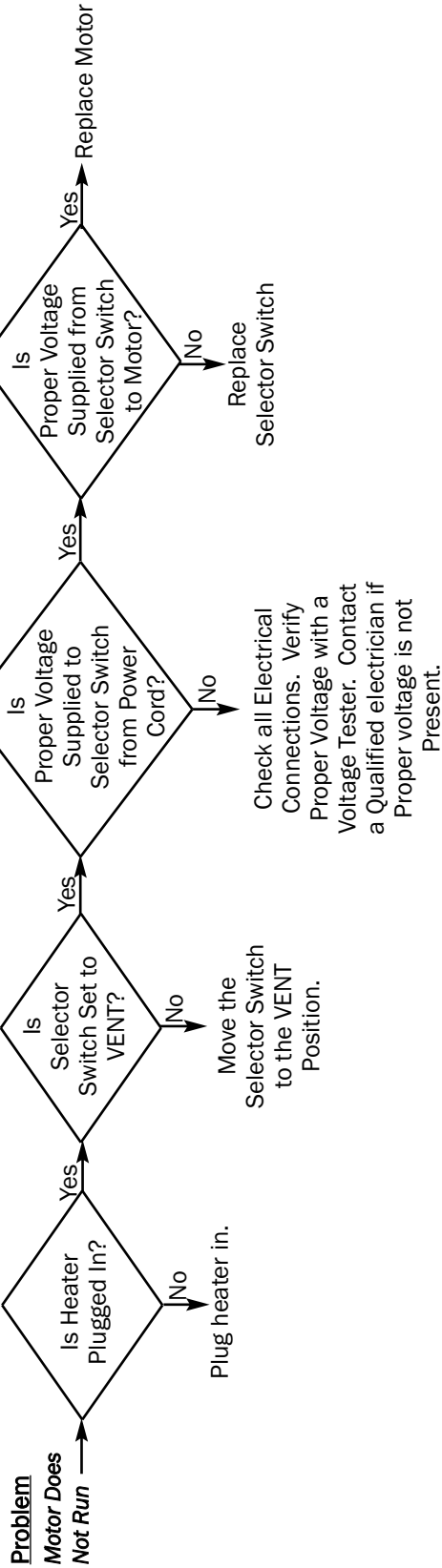

# Electrical Connection and Ladder Diagram

- BK: Black/Noir/Negro
  - BL: Blue/Bleu/Azul
  - BR: Brown/Bruin/Marrón
  - G: Green/Vert/Verde
  - GY: Gray/Gris
  - R: Red/Rouge/Rojo
  - W: White/Blanc/Blanco
  - Y: Yellow/Jaune/Amarillo
- APS: Air Proving Switch/  
Interrupteur de Vérification  
de Débit d'Air/Interruptor  
de Comprobación de Aire
  - DSI: Direct Sense Igniter/  
Allumeur Direct/Encendedor
  - GV: Gas Control Valve/Valve de  
Commande de Gaz/Válvula  
de Control de Gas
  - HL: High Limit Heat Switch/  
Interrupteur de Limite Élevée/  
Interruptor de Limite Superior
  - IGC: Ignition Control/  
Control de Allumage/  
Control de Encendido de Chispa
  - M: Motor/Moteur
  - MR: Motor Relay/ Relais de Moteur/  
Relé del Motor
  - PC: Power Cord/Cordon Electrique/  
Cordon de Potencia
  - SS: Selector Switch/Sélecteur/  
Interruptor de Selección
  - T: Thermostat/Termostato
  - TX: Transformer/Transformateur/  
Transformador
- ☀: LED/Voyant DEL/Luz LED
  - ⏚: Earth Ground/Mise a la terre/  
Conexión tierra

150-29935 REV.A

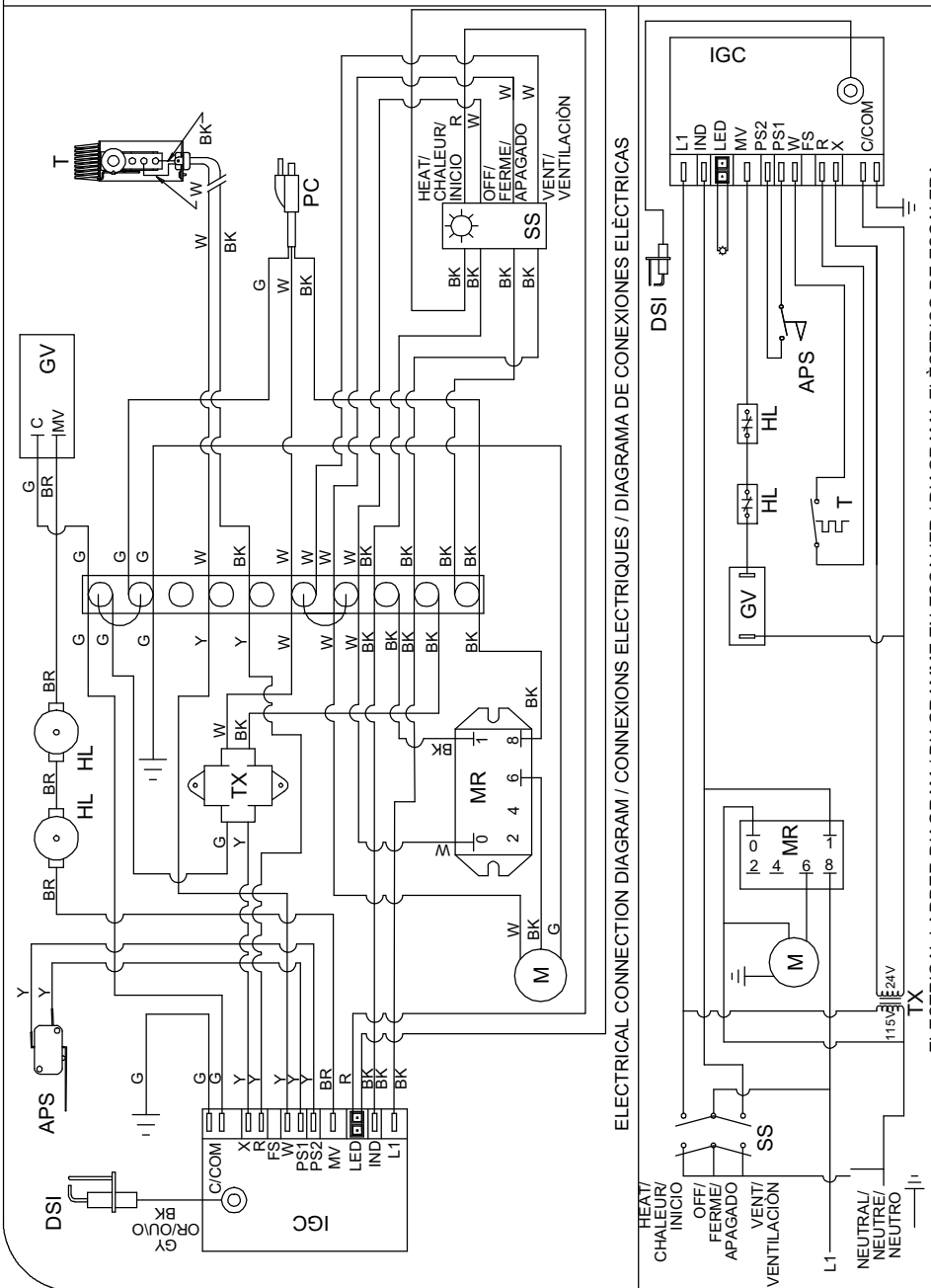

IF ANY OF THE ORIGINAL WIRING AS SUPPLIED WITH THE HEATER MUST BE REPLACED WITH WIRING MATERIAL HAVING A TEMPERATURE RATING OF AT LEAST 302F (150°C).  
S'IL FAUT REMPLACER UN DES FILS D'ORIGINE DE L'APPAREIL, IL FAUT LE REMPLACER PAR UN FIL AYANT UNE TEMPERATURE NOMINALE D'AU MOINS 302F (150°C).  
SI SE DEBE CAMBIAR CUALQUIER CABLE ORIGINAL PROPORCIONADO CON EL APARATO, SE DEBE CAMBIAR POR UN CABLE CON UNA CLASIFICACION DE TEMPERATURA DE AL MENOS 302F (150°C).

---

# Heater Component Function

## **Air Proving Switch**

Safety device used to insure that the proper air flow is being achieved before the gas valve is opened.

## **Belt**

Friction drive component used for transmission of power from motor to fan shaft. Used in conjunction with motor and fan sheaves.

## **Belt Tensioner**

A spring loaded device which applies proper tightness to the drive belt, thereby eliminating excess belt wear created by over or under tension.

## **Burner**

Cast iron component used to channel gas and provide an area at which the fuel may ignite.

## **Burner Orifice**

Brass metering device used to feed gas to burner at a specific rate.

## **Direct Spark Ignition Control Module**

Electronic printed circuit board which sends and receives voltages to various controls in an automatic ignition system. An important safety feature of the control board is that it will shut down the entire heater, thereby stopping the flow of fuel gas if burner flame goes out.

## **Fan Housing**

Chamber used for delivering air for efficient air movement.

## **Fan Wheel**

Component used in conjunction with the motor and fan housing to pull the hot air from heater and blow it into room for heating (also known as a squirrel cage).

## **Gas Control Valve**

Electrical device consisting of a low pressure regulator and electrical solenoids used for the control of gas flow to the burner assembly. A feature of the control valve is a built-in gas shut off which may be used to isolate the heater from its gas supply when servicing.

## **Gas Hose**

Flexible connector used to convey gas from supply line in building to heater.

## **Gas Selector Valve**

Allows easy gas conversion depending on gas being supplied at job site. Eliminates the need for changeout of the burner orifice .

## **Heat Chamber**

Metal "fire box" within the appliance that provides an area where burner flame mixes with combustion air, thereby providing heat.

## **High Limit Switch**

Safety device wired into the control system which is used to break an electrical circuit to the gas control valve in event of overheat situation.

## **Igniter**

Ignition device used on automatic direct spark ignition control systems. Ignites gas by spark.

## **Motor**

Electric device used to force preheated air through the heater and to circulate heat within a certain area. Converts electrical energy into mechanical energy.

## **Motor Relay**

Electrical component wired between ignition control and motor. Used to feed voltage to motor upon receipt of voltage from ignition control.

## **Pulleys**

Grooved friction drive components responsible for transmission of power from motor to fan shaft. Used in conjunction with V-Belt.

## **Regulator**

Mechanical device used in L.P. and natural gas distribution systems to reduce a higher inlet pressure to a preset lower pressure. The regulator is responsible to supply a steady outlet pressure to the heater(s) despite changes in inlet pressure, heater demand and weather conditions.

## **Selector Switch**

Electrical device which is used to allow the end user to use the heater in either a heating or ventilation application.

## **Thermostat**

Electrical device used as an automatic "on/off" switch which will respond to changes in temperature in a certain area. Can be wired so contacts in the thermostat open or close on temperature increase or decrease.

## **Transformer**

Electrical control used to accept line power supply primary voltage and reduce it to lower secondary voltage.

# Parts Identification

## PARTS SCHEMATIC

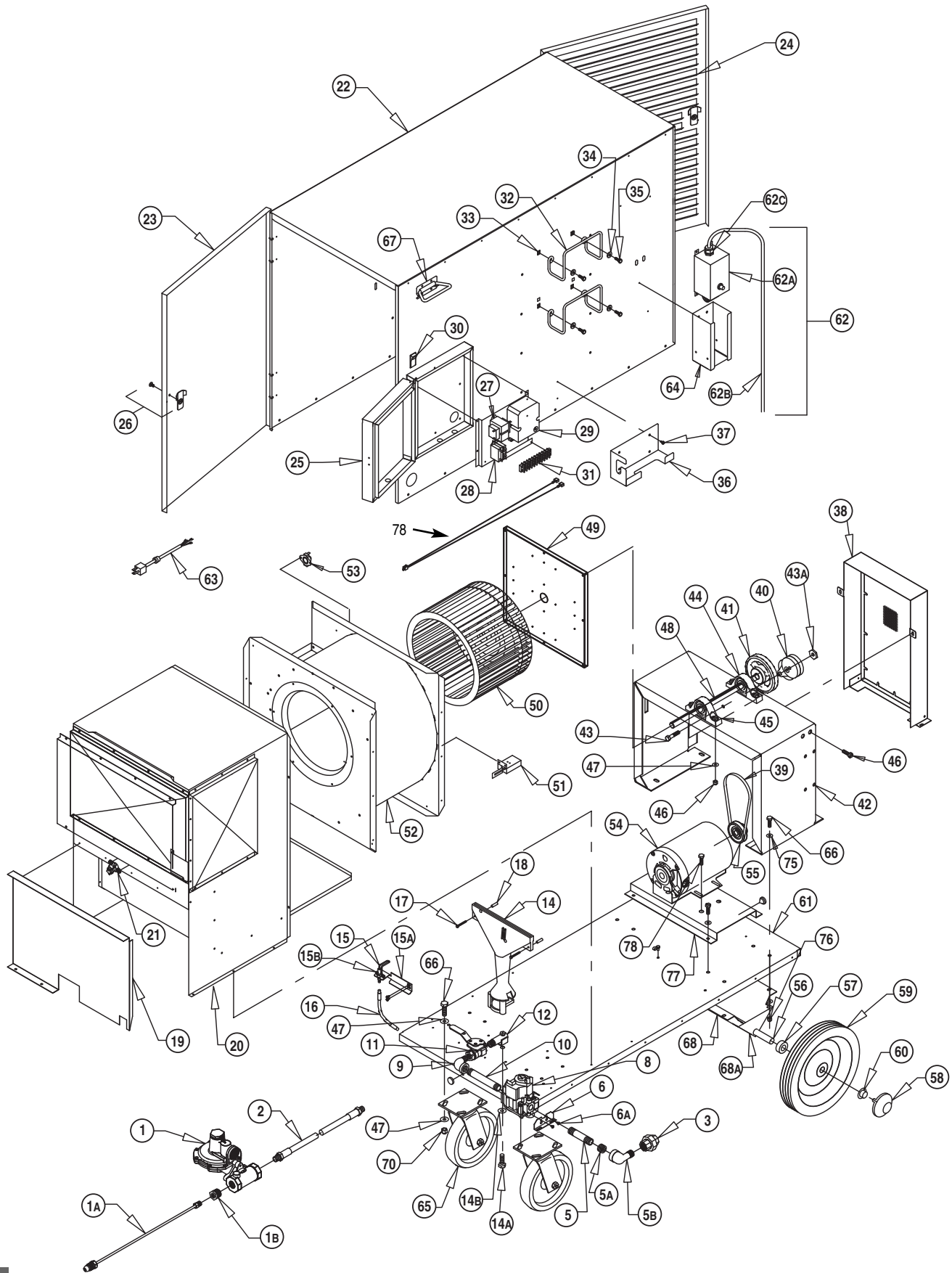

**PARTS LIST**

<b>Item</b>	<b>Description</b>	<b>Part Number</b>
1	Regulator	25141
1A	Pigtail Connector	Propane Gas 25774
1B	Bushing, 3/4 x 1/4	Propane Gas 25775
2	Hose, 3/4 ID x 15 Ft.	23078
3	Union	25272
5	Nipple, 1/2 x 4 In.	03128
5A	Bushing	08955
5b	Street Ell	25273
6	Bracket, Gas Control	21768
6A	Screws	09425
8	Valve, Gas Control	24025
9	Elbow, 1/2 NPT	01359
10	Nipple	02706
11	Gas Selector Valve	25826
12	Manifold w/ Burner Orifice	25828
13	Burner	571172
14A	Bolt, Burner	02692
14B	Washer	01589
15	Igniter	571662
15A	Bracket	22895
15B	Screws	07288
16	Lead, Ignition	24810
17	Screw, Burner Mounting	02688
18	Spacer, Burner	02687
19	Panel, Burner Access	24012
20	Chamber, Heat	571847
21	Switch, High Limit, Burner End, 325°F	81108
22	Case Assembly	573472
23	Panel, Case Access, Burner	573473
24	Panel, Case Access, Motor	573471
25	Panel, Control Box Cover	573474
26	Latch	570228
27	Transformer	09615
28	Relay	570221
29	Control Ignition	25590
30	Switch, Selector w/ L.E.D.	22017
31	Terminal Strip	22905
32	Hose Hanger	08936
33	Cage Nut	07708
34	Washer, 1/4	03054
35	Bolt, 1/4 - 20 x 3/4	11254
36	Bracket, Regulator Storage	22917
37	Screws. Regulator Storage Bracket and Thermostat Storage Bracket	07288
38	Guard, Belt	24021
39	Belt	24031
40	Belt Tensioner	25135
41	Pulley, Fan	23037
42	Drive Platform	25277
43	Bolt, 3/8 - 16 x 1	23128
44	Bearing, Pillow Block	25132
45	Bolt, 3/8 - 16 x 1 1/4	03147
46	Nut, 3/8 - 16	05100

**PARTS LIST (cont.)**

---

<b>Item</b>	<b>Description</b>	<b>Part Number</b>
47	Washer, 3/8	01589
48	Shaft, 3/4 Dia. with 3/16 keyway	25133-A
49	Panel, Fan Access	22887
50	Fan	22868
50A	Key, 3/16 in., Fan & Motor Sheaves, & Fan Shaft (Not Illustrated)	22955
51	Switch, Air Proving	09925
52	Housing, Fan	22882
53	Switch, High Limit, Fan End, 190°F	571400
54	Motor	571327
55	Pulley, Motor	23038
56	Axle, Wheel	22951
57	Spacer	07905
58	Hub Cap	07187
59	Wheel	22914
60	Cap, Retaining	01095
61	Base	24013
62	Thermostat Kit w/ 20 Ft. Cord	24041
62A	Thermostat	09381
62B	Cord, Thermostat	20164
62C	Connector, Liquid Tight	08948
63	Cord, Power, 10 Ft.	22907
64	Bracket, Thermostat Storage	23186
65	Wheel, Caster	23130
66	Bolt, 5/16 - 18	03141
67	Handle, Case	08534
68	Bracket, Axle Mount	25274
68A	Bracket, Axle	23113
76	Nut, 5/16 - 18	01680
77	Motor Mount	25276
78	Wire Harness, LED	24685



---

# Warranty Policy

---

## EQUIPMENT

L.B. White Co., Inc. warrants that the component parts of its heater are free from defects in material and workmanship, when properly installed, operated, and maintained in accordance with the Installation and Maintenance Instructions, safety guides and labels contained with each unit. If, **within 24 months from the date of purchase by the end user**, any component is found to be defective, L.B. White Co., Inc. will at its option, repair or replace the defective part or heater, with a new part or heater, F.O.B., Onalaska, Wisconsin.

Registering your product online with L.B.White will automatically qualify a unit and its component parts for warranty consideration. If a product has not been registered with L.B.White, a copy of the bill of sale will be required to establish warranty qualification. If neither is available, the warranty period will be 24 months from date of shipment from L B. White.

---

## PARTS

L.B. White Co., Inc. warrants that replacement parts purchased from the company and used on the appropriate L. B. White equipment are free from defects both in material and workmanship for **24 months from the date of purchase by the end user**. Warranty is automatic if a component is found defective within 24 months of the date code marked on the part. If the defect occurs more than 24 months later than the date code but within 24 months from the date of purchase by the end user, a copy of a bill of sale will be required to establish warranty qualification.

The warranty set forth above is the exclusive warranty provided by L.B. White, and all other warranties, including any implied warranties or merchantability or fitness for a particular purpose, are expressly disclaimed. In the event any implied warranty is not hereby effectively disclaimed due to operation of law, such implied warranty is limited in

duration to the duration of the applicable warranty stated above. The remedies set forth above are the sole and exclusive remedies available hereunder. L.B. White will not be liable for any incidental or consequential damages directly or indirectly related to the sale, handling or use of the equipment, and in any event L.B. White's liability in connection with the equipment, including for claims based on negligence or strict liability, is limited to the purchase price.

Some states do not allow limitations on how long an implied warranty lasts, so the above limitation may not apply to you. Some states do not allow the exclusion or limitation of incidental or consequential damages, so the above limitation or exclusion may not apply to you. This warranty gives you specific legal rights, and you may also have other rights which vary from state to state.

**To register your product and ensure full warranty, go to**

**[http://www.lbwhite.com/customer\\_care\\_center/product-registration/](http://www.lbwhite.com/customer_care_center/product-registration/). Please have the serial number(s) and model(s) handy for the products you are registering.**

---

## Replacement Parts and Service

Contact your local L.B. White dealer for replacement parts and service. You may also call the L.B. White Co., Inc. at 1-800-345-7200, for assistance, or email us at [customerservice@lbwhite.com](mailto:customerservice@lbwhite.com).

Be sure that you have your heater model number and configuration number when calling.