



Owner's Manual and Instructions

Premier Ductable Heaters

View this manual online at www.lbwhite.com



MODELS	INPUT (Btuh/kW)	FUEL
TS080	80,000/23.4	Propane Vapor Withdrawal or Natural Gas
TS170	170,000/49.8	

Certification by:



SCAN THIS QR CODE

with your smartphone or visit <http://goo.gl/5j21G> to view maintenance videos for L.B.White heaters.*



*Requires an app like QR Droid for Android or QR Reader for iPhone.

Congratulations!

You have purchased the finest circulating heater available.

Your new L.B. White heater incorporates the benefits from the most experienced manufacturer of heating products using state-of-the-art technology.

We, at L.B. White, **thank you** for your confidence in our products and welcome any suggestions or comments you may have...contact us at 1-800-345-7200, or email us at customerservice@lbwhite.com.

ATTENTION ALL USERS

This heater has been tested and evaluated by C.S.A. International in accordance with the requirements of Standard ANSI Z83.7• CSA 2.14 and is listed and approved as a ductable direct gas-fired forced-air construction heater with application for the temporary heating of buildings under construction, alteration, or repair. Additionally, this heater has been application reviewed and approved by C.S.A. International for U.S. and Canadian Tent Heating Applications with temporary human occupancy. If you are considering using this product for any application other than its intended use, then please contact your fuel gas supplier, or the L.B. White Co., Inc.



World Provider - Innovative Heating Solutions

411 Mason Street, Onalaska, WI 54650 ■ (800) 345 7200 ■ (608) 783 5691 ■ (608) 783 6115, fax ■ www.lbwhite.com

⚠ GENERAL HAZARD WARNING

- Failure to comply with the precautions and instructions provided with this heater, can result in:
 - Death
 - Serious bodily injury or burns
 - Property damage or loss from fire or explosion
 - Asphyxiation due to lack of adequate air supply or carbon monoxide poisoning
 - Electrical shock
- Read this Owner's Manual before installing or using this product.
- Only properly-trained service people should repair or install this heater.
- Save this Owner's Manual for future use and reference.
- Owner's Manuals and replacement labels are available at no charge. See website, or for assistance, contact L.B. White at 1-800-345-7200.

⚠ WARNING

- Proper gas supply pressure must be provided to the inlet of the heater.
- Refer to data plate for proper gas supply pressure.
- Gas pressure in excess of the maximum inlet pressure specified at the heater inlet can cause fires or explosions.
- Fires or explosions can lead to serious injury, death, or building damage.
- Gas pressure below the minimum inlet pressure specified at the heater inlet may cause improper combustion.
- Improper combustion can lead to asphyxiation or carbon monoxide poisoning and therefore serious injury or death.

⚠ WARNING

Fire and Explosion Hazard

- Not for home or recreational vehicle use.
- Installation of this heater in a home or recreational vehicle may result in a fire or explosion.
- Fire or explosions can cause property damage or loss of life.

FOR YOUR SAFETY

If you smell gas:

1. Open windows.
2. Don't touch electrical switches.
3. Extinguish any open flame.
4. Immediately call your gas supplier.

FOR YOUR SAFETY

Do not store or use gasoline or other flammable vapors and liquids in the vicinity of this or any other appliance.

⚠ WARNING

Fire and Explosion Hazard

- Keep solid combustibles a safe distance away from the heater.
- Solid combustibles include wood, paper, or plastic products, building materials and dust.
- Do not use the heater in spaces which contain or may contain volatile or airborne combustibles.
- Volatile or airborne combustibles include gasoline, solvents, paint thinner, dust particles or unknown chemicals.
- Failure to follow these instructions may result in a fire or explosion.
- Fire or explosions can lead to property damage, personal injury or loss of life.



Table of Contents

SECTION	PAGE
General Information	3
Heater Specifications	4
Safety Precautions	5
Installation Instructions	
General	7
Propane Gas Supply Sizing	8
Sliding Handle Assembly (Premier 170)	9
Hose Hanger, Regulator Storage Bracket & Thermostat Storage Bracket	9
Wheel, Leg & Lifting Handle Assembly (Premier 170)	10
Leg Assembly (Premier 80)	10
Hose and Regulator Assembly	11
Thermostat Assembly	11
Duct Kit Assembly	12
Unit Diffuser Assembly	12
End Diffuser Assembly	13
Connecting Regulator to Gas Supply	13
Start-Up Instructions	14
Shut-Down Instructions	15
Cleaning Instructions	15
Maintenance Instructions	15
Service Instructions	
General	16
Motor and Fan Wheel	16
Air Proving Switch	17
Igniter and Flame Sensor Assembly	17
Testing the Manual Reset High Limit Switches	18
Burner Orifice & Gas Control Valve	18
Gas Pressure Checks	20
Troubleshooting Information	21
Electrical Connection and Ladder Diagram, TS080/170	27
Heater Component Function	29
Parts Identification	
Parts Schematic and Parts List	
Premier 80	30 & 31
Premier 170	32 & 33
Warranty Policy	34
Replacement Parts and Service	34

General Information

This Owner's Manual includes all options and accessories commonly used on this heater.

When calling for technical service assistance, or for other specific information, always have model number, configuration number and serial number available. This information is contained on the dataplate.

This manual will instruct you in the operation and care of your unit. Have your qualified installer review this manual with you so that you fully understand the heater and how it functions.

The gas supply line installation, installation of the heater, and repair and servicing of the heater requires continuing expert training and knowledge of gas heaters and should not be attempted by anyone who is not so qualified. See page 6 for definition of the necessary qualifications.

Contact your local L.B. White distributor or the L.B. White Co., Inc. for assistance, or if you have any questions about the use of the equipment or its application.

The L.B. White Co., Inc. has a policy of continuous product improvement. It reserves the right to change specifications and design without notice.

Heater Specifications

SPECIFICATIONS		Model			
		TS080		TS170	
Fuel Type		Propane Gas	Natural Gas	Propane Gas	Natural Gas
Maximum Input (Btuh/kW)		80,000/23.4		170,000/49.8	
Burner Manifold Pressure (Inches W.C./kPa)		10.0/2.49	4.0/1.0	10.0/2.49	4.0/1.0
Inlet Gas Supply Pressure Acceptable at the Inlet of the Heater for Purpose of Input Adjustment (Inches W.C./kPa)	MAX.	13.5/3.36			
	MIN.	12.0/2.99	8.0/1.99	11.0/2.74	7.0/1.74
Fuel Consumption Per Hour		3.71 lbs./1.68 kg	80 cu.ft./2.27 m ³	7.88 lbs./3.57 kg	170 cu.ft./4.81 m ³
Motor Characteristics		Ball Bearing			
		1/8 H.P./93 Watts 1,100 RPM		1/3 H.P./ 248 Watts 1,100 RPM	
Electrical Supply (Volts/Hz/Phase)		115/60/1			
Amp Draw	STARTING	5.0		7.3	
	CONTINUOUS OPERATION	1.5		5.0	
Dimensions (Inches/cm) L x W x H		29.5 x 13.5 x 20/75 x 34 x 51		30.75x18.25 x 28.25/78 x 46.3 x 71.7	
Minimum Safe Distances From Nearest Combustible Materials (feet/meter)	TOP	1/0.3			
	SIDES	1/0.3			
	BACK	1/0.3			
	BLOWER OUTLET	6/1.83			
	GAS SUPPLY	Propane Gas - U.S: 6/1.83, Canada: 3.05 Natural Gas - N/A			
Net Weight (lbs/kg)		81/36.7		153/69.4	
Shipping Weight (lbs/kg)		88/38.5		161/73	
Minimum Ambient Temperature in Which Heater May Be Used		- 20 °F/- 29 °C			

Safety Precautions

WARNING **Asphyxiation Hazard**

- Do not use this heater for heating human living quarters, garages, workshops, or other such confined spaces.
- Do not use in unventilated areas.
- The flow of combustion and ventilation air must not be obstructed.
- Proper ventilation air must be provided to support the combustion air requirements of the heater being used.
- Lack of proper ventilation air will lead to improper combustion.
- Improper combustion can lead to carbon monoxide poisoning leading to serious injury or death. Symptoms of carbon monoxide poisoning can include headaches, dizziness and difficulty in breathing.
- Proper ventilation air for combustion must be provided in accordance with OSHA 29 CFR 1926.154, Temporary Heating Devices, ANSI A10.10, Safety Requirements for Temporary and Portable Space Heating Devices, or the Natural Gas and Propane Installation Code, CAN/CSA B149.1 as appropriate.

FUEL GAS ODOR

Propane gas and natural gas have man-made odorants added specifically for detection of fuel gas leaks.

If a gas leak occurs, you should be able to smell the fuel gas
THAT'S YOUR SIGNAL TO GO INTO IMMEDIATE ACTION!

- Do not take any action that could ignite the fuel gas. Do not operate any electrical switches. Do not pull any power supply or extension cords. Do not light matches or any other source of flame. Do not use your telephone.
- Get everyone out of the building and away from the area immediately.
- Close all propane gas tank or cylinder fuel supply valves, or the main fuel supply valve located at the meter if you use natural gas.
- Propane gas is heavier than air and may settle in low areas. When you have reason to suspect a propane leak, keep out of all low areas.
- Use your neighbor's phone and call your fuel gas supplier and your fire department. Do not re-enter the building or area.
- Stay out of the building and away from the area until declared safe by the firefighters and your fuel gas supplier.
- **FINALLY**, let the fuel gas service person and the firefighters check for escaped gas. Have them air out the building and area before you return. Properly trained service people must repair the leak, check for further leakages, and then relight the appliance for you.

ODOR FADING -- NO ODOR DETECTED

- Some people cannot smell well. Some people cannot smell the odor of the man-made chemical added to propane or natural gas. You must determine if you can smell the odorant in these fuel gases.
- Learn to recognize the odor of propane gas and natural gas. Local propane gas dealers will be more than happy to give you a scratch and sniff pamphlet. Use it to become familiar with the fuel gas odor.
- Smoking can decrease your ability to smell. Being around an odor for a period of time can affect your sensitivity to that particular odor.
- The odorant in propane gas and natural gas is colorless and the intensity of its odor can fade under some circumstances.
- If there is an underground leak, the movement of gas through the soil can filter the odorant.
- Propane gas odor may differ in intensity at different levels. Since propane gas is heavier than air, there may be more odor at lower levels.
- **Always be sensitive to the slightest gas odor.** If you continue to detect any gas odor, no matter how small, treat it as a serious leak. Immediately go into action as discussed previously.

ATTENTION -- CRITICAL POINTS TO REMEMBER!

- Propane gas has a distinctive odor. Learn to recognize these odors. (Reference Fuel Gas Odor and Odor Fading sections above.)
- If you have not been properly trained in repair and service of propane gas then do not attempt to light heater, perform service or repairs, or make any adjustments to the heater on the propane gas fuel system.
- Even if you are not properly trained in the service and repair of the heater, **ALWAYS** be consciously aware of the odors of propane gas and natural gas.
- A periodic sniff test around the heater or at the heater's joints; i.e. hose, connections, etc., is a good safety practice under any conditions. If you smell even a small amount of gas, **CONTACT YOUR FUEL GAS SUPPLIER IMMEDIATELY. DO NOT WAIT!**

1. Do not attempt to install, repair, or service this heater or the gas supply line unless you have continuing expert training and knowledge of gas heaters.

Qualifications for service and installation of this equipment are as follows:

 - a. To be a qualified gas heater service person, you must have sufficient training and experience to handle all aspects of gas-fired heater installation, service and repair. This includes the task of installation, troubleshooting, replacement of defective parts and testing of the heater. You must be able to place the heater into a continuing safe and normal operating condition. You must completely familiarize yourself with each model heater by reading and complying with the safety instructions, labels, Owner's Manual, etc., that is provided with each heater.
 - b. To be a qualified gas installation person, you must have sufficient training and experience to handle all aspects of installing, repairing and altering gas lines, including selecting and installing the proper equipment, and selecting proper pipe and tank size to be used. This must be done in accordance with all local, state and national codes as well as the manufacturer's requirements.
 - c. In the Commonwealth of Massachusetts, this product must be installed by a gas fitter licensed in the Commonwealth of Massachusetts.
2. All installations and applications of L.B. White heaters must meet all relevant local, state and national codes. Included are L.P. gas, natural gas, electrical, and safety codes. Your local fuel gas supplier, a local licensed electrician, the local fire department or similar government agencies, or your insurance agent can help you determine code requirements.

U.S. Installations:

 - NFPA 102, Standard for Assembly Seating, Tents and Membrane Structures.
 - ANSI/NFPA 58, latest edition, Standard for Storage and Handling of Liquefied Petroleum Gas and/or
 - ANSI Z223.1/NFPA 54, National Fuel Gas Code
 - ANSI/NFPA 70, National Electrical Code.

Canadian Installations:

 - CSA B149.1 Natural Gas and Propane Gas Installation Code.
 - CSA C22.1 Part 1 Standard Canadian Electrical Code, and CSA C22.2 No.3, Electrical Features of Fuel Burning Equipment.
3. We cannot anticipate every use which maybe made of our heaters. Check with the local fire safety authority if you have questions about applications.
4. Forced air heaters shall not be directed toward any propane gas container within 20 feet/6.10 meters. Do not wash the heater. Use only compressed air, a soft brush or dry cloth to clean the interior of the heater and it's components.
5. For safety, this heater is equipped with manual reset high limit switches, an air-proving switch and a redundant gas control valve. Never operate the heater with any safety device that has been bypassed. Do not operate this heater unless all of these features are fully functioning.
6. Do not locate fuel gas containers or fuel supply hoses anywhere near the blower outlet of the heater.
7. Do not block air intakes or discharge outlets of the heater. Doing so may cause improper combustion or damage to heater components leading to property damage.
8. The hose assembly shall be visually inspected on a daily basis after heater relocation and when the heater is in use. If it is evident there is excessive abrasion or wear, or if the hose is cut, it must be replaced prior to the heater being put into operation. The hose assembly shall be protected from building materials, and contact with hot surfaces during use. The hose assembly shall be that specified by the manufacturer. See parts list.
9. Check for gas leaks and proper function upon heater installation, when relocating, and after servicing. Refer to leak check instructions within installation section of this manual.
10. This heater should be inspected for proper operation by a qualified service person before each use and at least annually.
11. Always turn off the gas supply to the heater if the heater is not going to be used in the heating of the work space.
12. This heater is equipped with a three-prong (grounding) plug for your protection against shock hazard and must be plugged directly into a properly grounded three-prong receptacle. Failure to use a properly grounded receptacle can result in electrical shock, personal injury, or death.
13. If gas flow is interrupted and flame goes out, do not relight the heater until you are that all gas that may have accumulated has cleared away. In any event, do not relight the heater for at least 5 minutes.
14. Minimum propane gas supply cylinder size to be used shall be 100 lb./45 kg when using a cylinder supply system. The system must be arranged to provide vapor withdrawal from the operating cylinder.
15. When the heater is to be stored indoors, the connection between the propane gas supply cylinder(s) and the heater must be disconnected and the cylinder(s) removed form the heater and stored in accordance with the Standard for the Storage and Handling of Liquefied Petroleum Gases, ANSI/NFPA 58 or Standard CSA B149.1 Natural Gas and Propane Installation Code as appropriate.
16. Propane gas supply containers have left handed threads. Use the manual hand wheel supplied with the regulator to make a connection of the regulator's P.O.L. fitting into the cylinders' gas supply valve.
17. Use pipe joint compound that is resistant to propane and natural gas.

Installation Instructions

GENERAL

WARNING

Fire and Explosion Hazard

Can cause property damage, severe injury or death

1. To avoid dangerous accumulation of fuel gas, turn off gas supply at the heater service valve before starting installation, and perform gas leak test after completion of installation.
2. Do not force the gas control knob. Use only your hand to turn the gas control knob. Never use any tools. If the knob will not operate by normal hand pressure the gas control valve should be replaced by a qualified service technician. Force or attempted repair may result in fire or explosion.

1. Read all safety precautions and follow L.B. White recommendations when installing this heater. If during the installation or relocating of heater, you suspect that a part is damaged or defective, call a qualified service agency for repair or replacement.
2. The heating equipment must be properly positioned on a flat, stable, and horizontal surface before use. Observe and obey all minimum safe distances of the heater to the nearest combustible materials. Safe distances are given on the heater dataplate and on page 4 of this manual.
3. **L.P Gas Installation Requirements**
 - All LP. gas containers must be placed at least 5 feet/1.52 meters from the nearest tent wall structure.
 - Ensure all L.P. gas containers are secured and protected from all people, vehicular traffic and contact.
 - L.P. gas containers must be located on a flat, level, and stable surface.
 - L.P. gas cylinders (a.k.a. 100 lb/45 kg. cylinders/tanks) must be secured from tip-over.

Contact your local authorities, L.P. gas dealers, or fire marshalls for specifics dealing with installation in your area

4. This heater may be installed either indoors or outdoors. For outdoor installations, additional accessories are needed to properly provide heated air to the inside of the tent. These accessories are as follows:

Unit Diffuser:

This accessory provides the necessary clearance to combustible materials and also spreads the heated air inside the tent. Local codes may require a 3.04 m separation between the tent and the heater. In this case the unit mounted diffuser shall not be used.

Unit Diffuser Part Numbers:

Premier 80: 26349, Premier 170: 26351

Duct Kit, 12 in./3 m. diameter x 12 ft/3.65 m. length:

This accessory provides for locating the heater 10 ft./3.04 meters away from the tent as required by some local codes.

Duct Kit Part Numbers:

Gray 26346
White 26347
Clear 26348

End Diffuser:

This accessory is used with the 12 in./3 m. diameter x 12 ft./3.65 m. duct. It is placed under the tent edge and provides for spreading of the heated air inside the tent.

End Diffuser Part Number: 26350

DO NOT USE ANY OTHER DUCTWORK, DUCTING, FIELD FABRICATED DUCTS, TARPS, STOVE PIPE, or any other means of making the connection between the heater and the inside of the tent.

5. When using the unit diffuser or end diffuser air distribution accessories, ensure the tent material is laid within the accessory's channel, and the tent material is firmly anchored to hold the tent material securely within the channel. See pages 12 and 13 for specifics when using these air distribution accessories.
6. The heater's gas pressure regulator (with pressure relief valve) must be protected from adverse weather conditions (rain, ice, snow) as well as from building materials (tar, concrete, plaster, etc.) which can affect safe operation and could result in property damage or injury.
7. Insure that all accessories that ship within the heater have been removed from inside the heater and installed.
8. Check all connections for gas leaks using approved gas leak detectors. Gas leak testing is performed as follows:

WARNING

Fire and Explosion Hazard

- Do not use open flame (matches, torches, candles, etc.) in checking for gas leaks.
- Use only approved leak detectors.
- Failure to follow this warning can lead to fires or explosions.
- Fires or explosions can lead to property damage, personal injury or loss of life.

- Check all pipe connections, hose connections, fittings and adapters upstream of the gas control with approved gas leak detectors.
- In the event a gas leak is detected, check the components involved for cleanliness and

- proper application of pipe compound before further tightening.
 - Tighten the gas connections as necessary to stop the leak.
 - After all connections are checked and any leaks are stopped, turn on the main burner.
 - Stand clear while the main burner ignites to prevent injury caused from hidden leaks that could cause flashback.
 - With the main burner in operation, check all connections, hose connections, fittings and joints as well as the gas control valve inlet and outlet connections with approved gas leak detectors.
 - If a leak is detected, check the components involved for cleanliness in the thread areas and proper application of pipe compound before further tightening.
 - Tighten the gas connection as necessary to stop the leak.
 - If necessary, replace the parts or components involved if the leak cannot be stopped.
 - Ensure all gas leaks have been identified and repaired before proceeding.
9. A qualified service agency must check for proper operating gas pressure upon installation of the heater.
 10. Light according to instructions on heater or within owner's manual.
 11. The heater must have the proper gas regulator for the application. Use only the L.B. White regulator originally supplied with the heater. This regulator includes a POL fitting incorporating an excess flow valve. The excess flow valve is a safety device which protects against discharge from the propane gas supply container if the regulator is broken off. If the POL fitting is ever replaced, it needs to be replaced with an L.B. White POL fitting. Failure to do so can result in fires, explosions, loss of property, injury or death.
 12. A regulator must be connected to the gas supply so that the pressure to the inlet of the gas control valve is regulated within the range specified on the dataplate at all times. Contact your gas supplier or the L.B.white Co., if you have any questions.
 13. This heater is configured for use for propane gas vapor withdrawal only. Do not use the heater in an propane gas liquid withdrawal system or application. If you are in doubt, contact the L.B. White Co., Inc.
 14. The heater must be installed so as not to interfere with or obstruct normal exits, emergency exits, doors and walkways.
 15. Railing, fencing or suitable substitute materials must be used to keep the heating equipment from any people using and visiting the structure.
 16. The unit shall be located so that rain, ice, or snow drainage from the structure does not affect equipment operation. If the unit is mounted outside, it must be mounted above any pooled or standing water. If the unit is to be located on the ground, a surrounding trench is recommended to drain any rain, ice or snow away from the unit.
 17. The ground and surrounding terrain must be cleared of any combustible vegetation and other combustible materials when the heater is mounted outside.
 18. Eventually, like all electrical/mechanical devices, the thermostat can fail. Thermostat failure may result in an underheating condition. The thermostat should be tested to make sure it turns the heater on and off within a temperature differential of $\pm 3^{\circ}\text{F}$ ($\pm 1.5^{\circ}\text{C}$).
 19. Take time to understand how to operate and maintain the heater by using this Owner's Manual. Make sure you know how to shut off the gas supply to the building and also to the individual heater. Contact your fuel gas supplier if you have any questions.
 20. Any defects found in performing any of the service or maintenance procedures must be eliminated and defective parts replaced immediately. The heater must be retested by properly qualified service personnel before placing the heater back into use.

PROPANE GAS SUPPLY SIZING

The vaporization of propane is affected by several factors: the surface area of the container, the liquid level of propane, temperature surrounding the container, and the relative humidity. All of these factors are specific to a site. Therefore, a degree of experience and judgement is required to select the proper propane supply.

Although experience is the best guide, the following recommendations can be used as a starting point. The table is based on experience in northern climates where cold weather and high humidity are prevalent in the winter. If more or less favorable conditions prevail at a specific site, adjustments can be made on the basis of experience.

Recommended Propane Gas Supply

Average Temp ° F/°C		50/10	40/4.4	30/-1.1	20/-6.7	10-12.2	0/-17.8	010/-23
Number of 100 lb. /45 KG Cylinders to Use Per Heater	TS080	1	1	2	2	2	2	2
	TS170	2	2	3	3	3	3	3

* Cylinders must be manifolded together to allow simultaneous vapor withdrawal from all cylinders.

SLIDING HANDLE Premier 170

The Premier 170 is equipped with sliding handles for convenient “wheel-barrow” style mobility.

- Depress the snap-button on the underside of the sliding handle storage bracket.
- Fully extend both handles until the snap button locks into place.
- For storage, depress the snap button and push the handles to fully retracted position.

FIG. 1

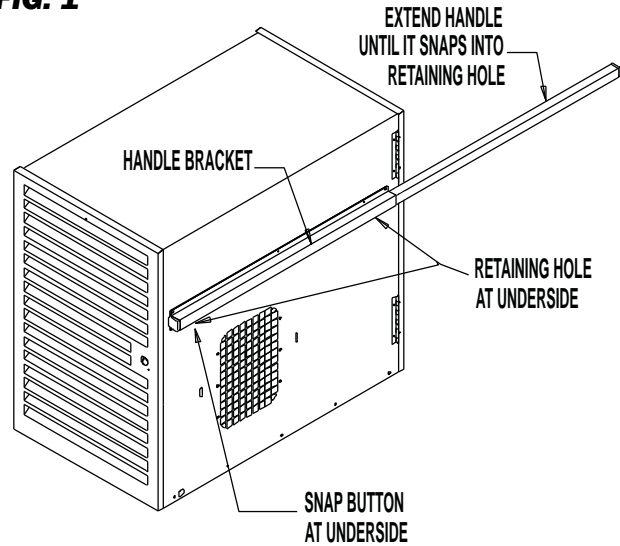

HOSE HANGER, REGULATOR STORAGE BRACKET & THERMOSTAT STORAGE BRACKET ASSEMBLY

1. Hose Hanger Assembly

- a. Align wire hose hanger to cage nuts on back of heater.
- b. Mount the hanger using the 1/4-20 x 3/4 in. bolts and 1/4 in. flat washers. Tighten securely. See Fig. 2.

2. Thermostat Storage Bracket Assembly

- a. Align regulator storage bracket to the four 1/8 in. diameter holes on heater case back.
- b. Mount the storage bracket to the case using the four 3/8 in. hex head screws. Tighten securely. See Fig. 2. Store the thermostat as shown in Fig. 3 when not in use.

3. Regulator Storage Bracket Assembly (PREMIER 170)

- a. Align regulator storage bracket to the two 1/8 in. diameter holes on heater case back.
- b. Mount the storage bracket to the case using the two 3/8 in. hex head screws at this point. Tighten securely. See Fig. 2.

FIG. 2

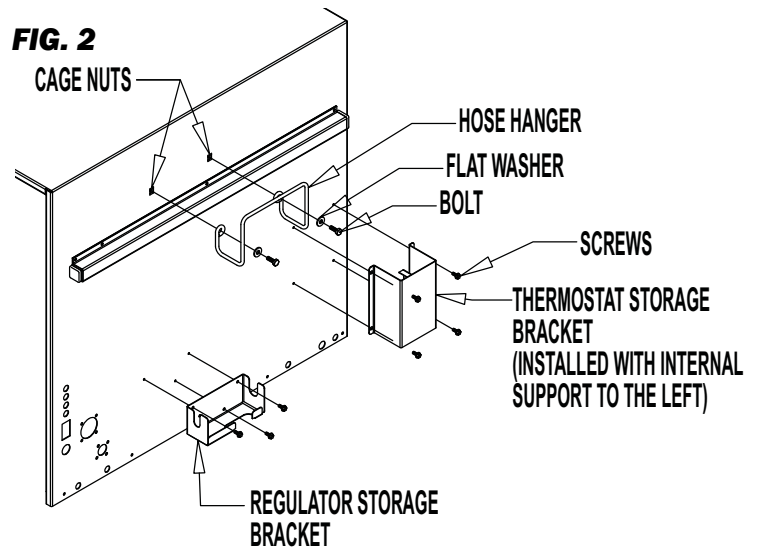
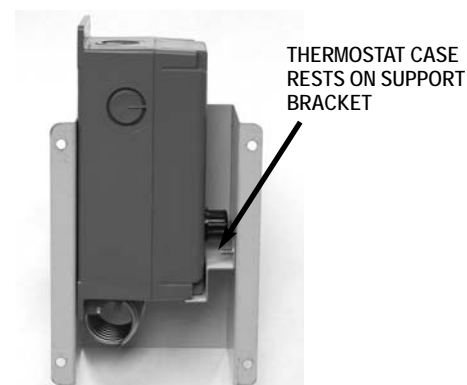

FIG. 3

INTERNAL VIEW

Thermostat Storage



WHEEL, LEG & LIFTING HANDLE ASSEMBLY Premier 170

See Fig. 4 for assembly of components. Ensure all hardware is tightened securely.

FIG. 4

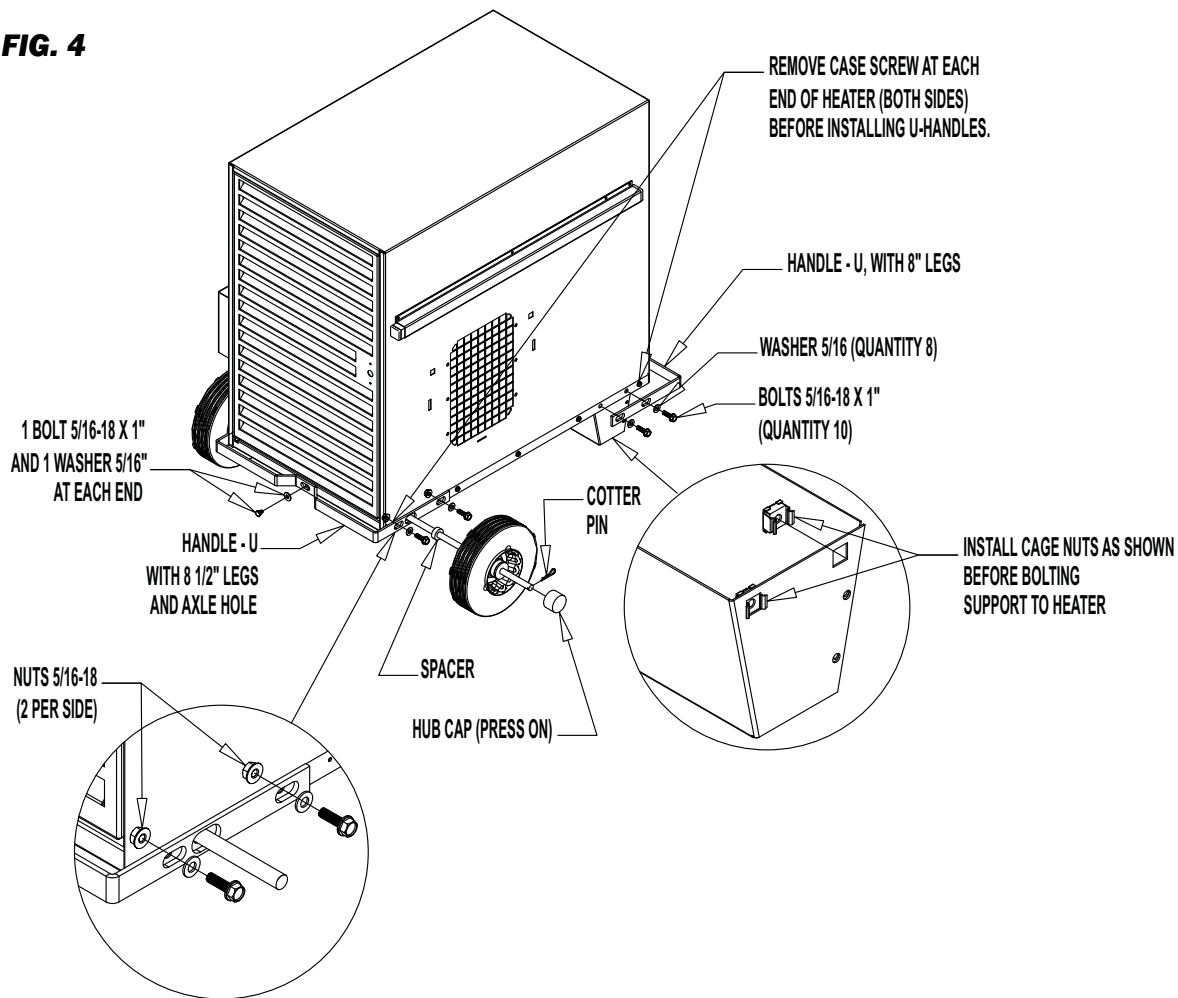

LEG ASSEMBLY Premier 80

Assemble the legs to the heater as shown. Tighten all hardware securely.

FIG. 5

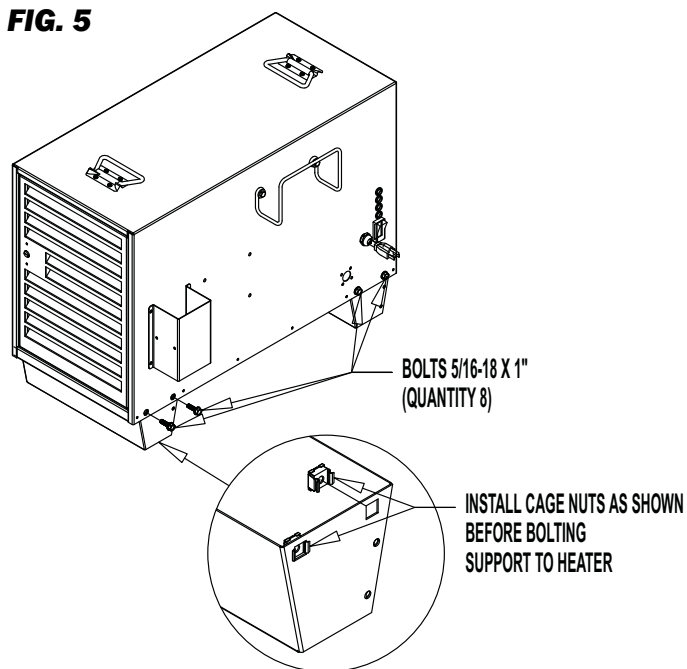

HOSE AND REGULATOR ASSEMBLY

1. Connect rigid end of hose to regulator outlet. Connect other end to hose adapter at heater. Tighten securely. See Fig 6.

FIG. 6

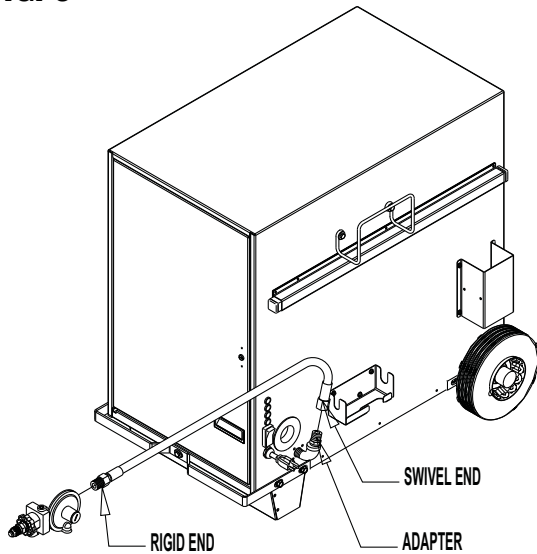

2. The hose may be coiled up and hung on the hose hanger as shown in Fig. 7.
3. For Premier 170 heaters, store the regulator in the storage bracket (Fig. 7) when the regulator is not in use.

FIG. 7

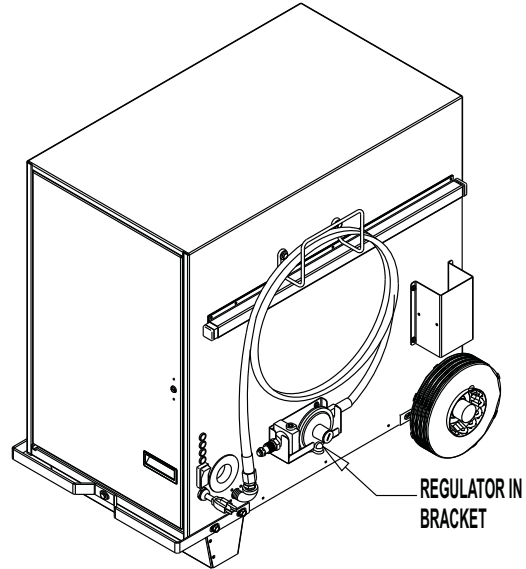

THERMOSTAT ASSEMBLY

1. Connect male plug on heater into female side of series tap plug on thermostat. See Fig. 8.
2. Plug male side of series tap plug into grounded, heavy-duty, electrical extension cord. Plug extension cord into approved electrical outlet.

FIG. 8

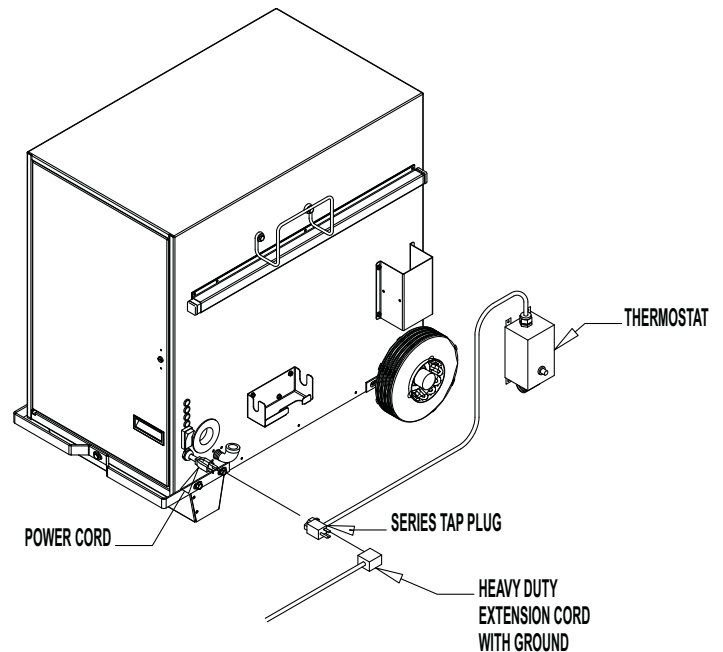

DUCT KIT ASSEMBLY Accessory 26346

1. Extend duct kit to 12 ft./3.65 m. length.
2. See Fig. 9 for installation of duct. Hand tighten the screws snugly. (Note: Slots are also provided at the sides of heater's air discharge to accommodate earlier style duct adapters with tab mounting configuration.)
3. Position duct as shown. Eliminate any kinks in duct.

FIG. 9

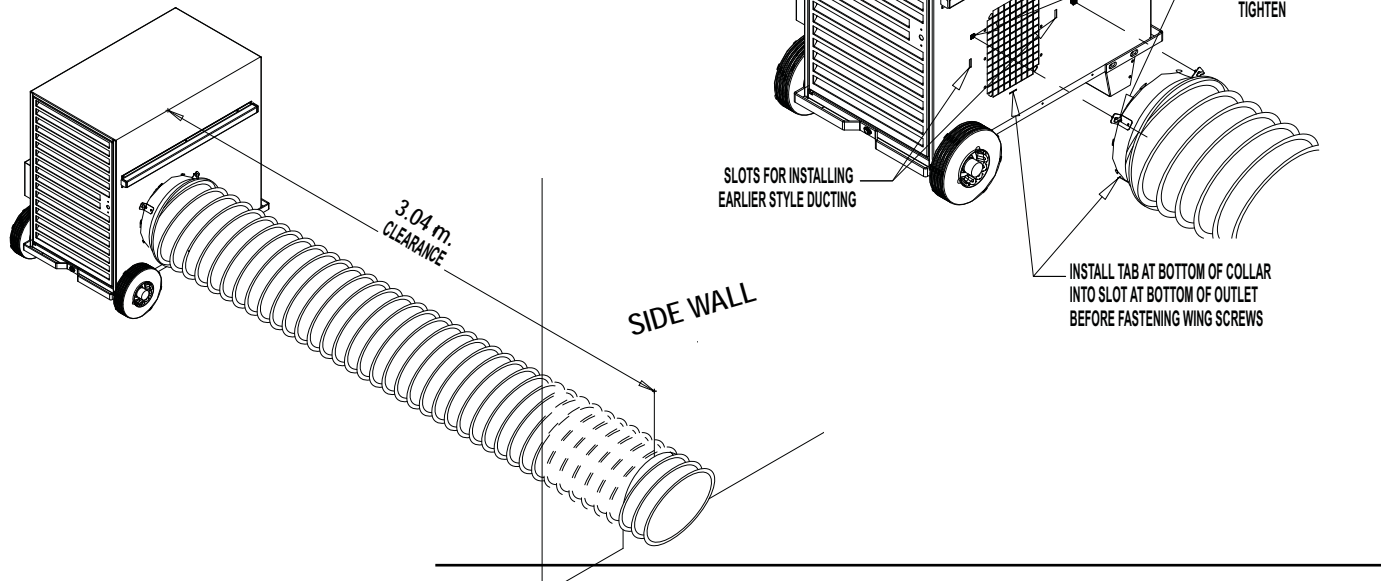

UNIT DIFFUSER Accessory 26349 (Premier 80) & 26351 (Premier 170)

1. See Fig. 10 for installation of unit diffuser. Hand tighten the screws snugly. (Note: Slots are provided to accommodate earlier style unit diffusers with tab mounting.)
2. Position the diffuser under the tent wall as shown. Lay the tent material within the channel of the diffuser. Ensure the material is securely anchored within the channel to prevent contact with the heater. See below for typical installation.

FIG. 10

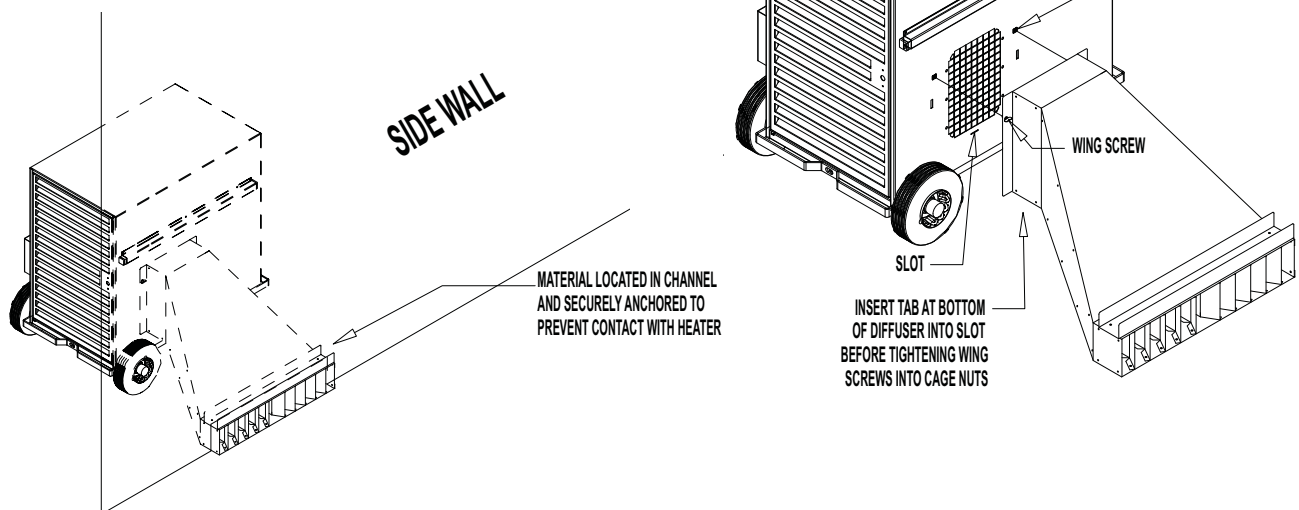

END DIFFUSER Accessory 26350

1. Wrap the duct clamp around duct and collar. Saddle of clamp lays over duct coil. Connect clamp ends together and tighten securely. See Fig. 11.

FIG. 11

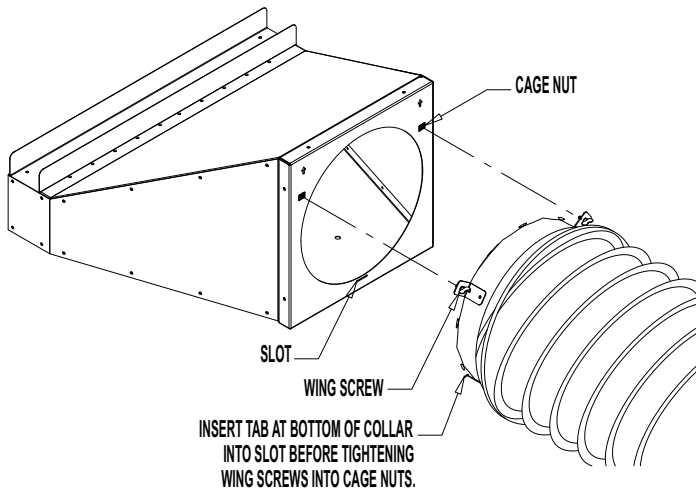

2. Position the diffuser under the tent wall as shown. Lay the tent material within the channel of the diffuser. Ensure the material is securely anchored within the channel. See Fig. 12.

FIG. 12

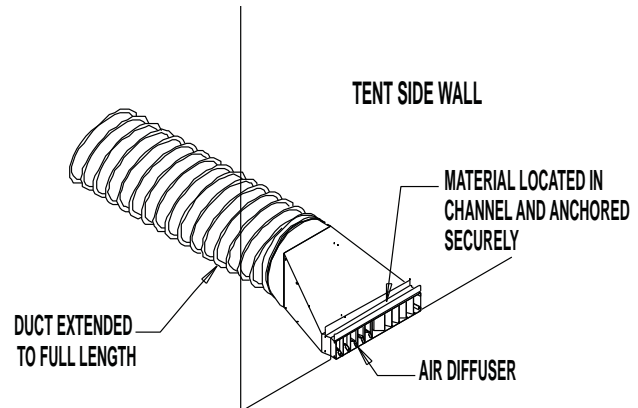

CONNECTING REGULATOR TO GAS SUPPLY

- Only use the L.B. White regulator supplied with the heater.
- The heater must be regulated at all times for proper operation.
- The regulator must be installed so its vent are directed downward.
- Leak check all regulator connections whenever the regulator is connected to the gas supply.

Propane Gas Heaters

1. Remove the cap from the POL fitting. Insert the POL stem into the cylinder valve. Push the spring loaded hand wheel up against the threaded nut. Turning counter clockwise, thread the POL nut into into the container valve using the hand wheel. Firmly tighten. See Fig. 13.

FIG. 13

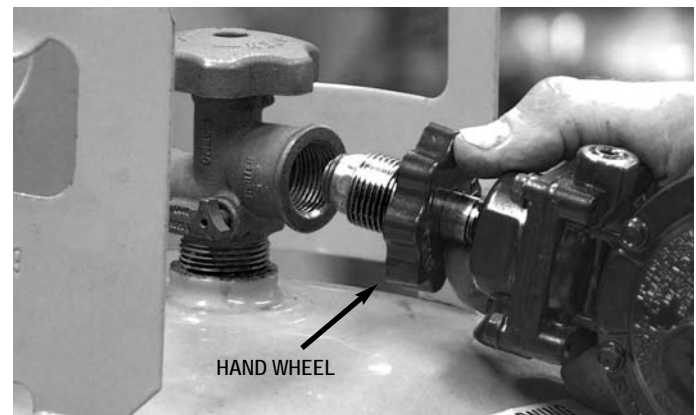

2. Slowly open the cylinder valve. This will prevent lock-up of the excess flow valve built within POL stem.
3. When storing or transporting the heater, ensure the POL fitting is protected from damage and water entry.

Natural Gas Heaters

- A regulator is required if the supply pressure to the heater is above the maximum pressure stated on the heater's dataplate.
- Connect the natural gas regulator (part # 09795) to the natural gas supply line. Gas supply pressure to the regulator must be a minimum of 14 in.W.C./3.48 kPa.

Start-Up Instructions

1. Connect the electrical cord to an approved electrical outlet.

A selector switch located on the back of the heater allows heater operation in either heating or ventilation (no heat) modes. See Fig. 15.

A. Heat Mode Operation

- a. Open all manual fuel supply valves. Check for gas leaks using an approved leak detector. The gas control valve in the heater has a manual shut-off feature incorporated into the valve assembly. Ensure the indicator on the valve is positioned to ON. See Fig 14.

FIG. 14

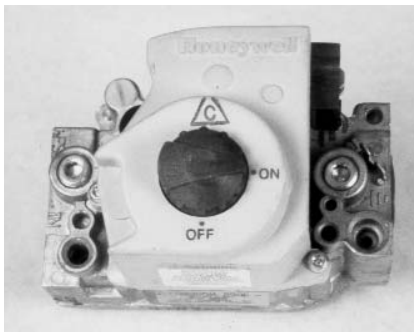

- b. Push the selector switch to heat.  See Fig.15.
- c. Set the thermostat above room temperature
 - The fan motor will start
 - Igniter will spark
 - Ignition occurs
- d. The thermostat cycles the heater on and off based on set point.

(It is normal for air to be trapped in the gas hose on new installations. The heater may attempt more than one trial for ignition before air is finally purged from line and ignition takes place.)

FIG. 15



When the switch is set to heat, four status lights (see Fig.15) will be activated in sequence as specific circuits are checked by the ignition control. **If the heater does not light, and a status light is off**, refer to the troubleshooting label on the inside of the heater's burner end access door or the troubleshooting of the manual.

B. Vent Mode Operation

- Push the selector switch to off, **O**, then to vent. 
- Only the fan motor will operate. The igniter will not spark, nor will ignition occur.

The ventilation feature is used when air circulation is required. The heater will not cycle on its thermostat setting.

C. Off **O**

1. Position the switch to midpoint **O**.
2. Do not exceed input rating stamped on nameplate or manufacturer's recommended burner orifice pressure for size orifice(s) used. Make certain that the primary air supply to main burner is open and free of dust, dirt and debris for complete, proper combustion.

Shut-Down Instructions

For normal shut-down, set the thermostat below room temperature. When servicing or performing maintenance, follow steps 1 - 5.

1. Close the fuel supply valve.
2. Allow the heater to burn off any fuel gas remaining in the gas supply line.
3. Set the thermostat to "Off" or "No Heat".
4. Position selector switch to **O** (off).
5. Disconnect the heater from its gas and electrical supplies.

Cleaning Instructions



WARNING Fire, Burn, and Explosion Hazard

- This heater contains electrical and mechanical components in the gas management, and safety systems.
- Such components may become inoperative or fail due to dust, dirt, wear and aging.
- Periodic cleaning and inspection as well as proper maintenance are essential to avoid serious injury or property damage.

1. Before cleaning, shut off all gas supply valves and disconnect electrical supply.
2. The heater should have dirt or dust removed periodically:
 - a. Before each use give the heater a general cleaning using compressed air or a soft brush or dry rag on its case and internal components. At this time, dust off the motor case to prevent the motor from over-heating.
 - b. At least once a year, give the heater a thorough cleaning. At this time, remove the fan and motor assembly and brush or blow off the fan blade assembly. Additionally, make sure the burner air inlet venturi ports and the casting are free of dust accumulation.



WARNING

Do not use a pressure washer, water, or liquid cleaning solution on any gas controls. Use of a pressure washer, water, or liquid cleaning solution on the control components can cause severe personal injury or property damage due to water and/or liquids:

- In electrical components, and wires causing electrical shock or equipment failure.
- On gas control valves causing corrosion which can result in gas leaks and fire or explosion from the leak.

Clean all components of the heater with pressurized air, a dry brush, or a dry cloth.

Maintenance Instructions

1. The area surrounding the heater shall be kept clear and free from combustible materials, gasoline, and other flammable vapors and liquids.
2. Have your gas supplier check all gas piping annually for leaks or restrictions in gas lines.
3. Regulators must be periodically inspected to make sure the regulator vents are not blocked. Debris, insects, insect nests, snow, or ice on a regulator can block vents and cause excess pressure at the heater.
4. Regulators can wear out and function improperly. Have your gas supplier check the date codes on all regulators installed and check delivery pressures to the heater to make sure that the regulator is reliable.
5. Check all wiring, associated terminals, and electrical components within the heater for corrosion, frayed or cut insulation, tight connections, etc. Repair or replace as necessary.
6. Review all heater markings (i.e. wiring diagram, warnings, start-up, shut-down, troubleshooting, etc.) at the time of maintenance for legibility. Make sure none are cut, torn, or otherwise damaged. Any damaged markings must be replaced immediately by contacting the L.B. White Co., Inc. Dataplates, start-up and shut-down instructions and warnings are available at no cost. A nominal charge will be applied for wiring diagrams.

**WARNING
Burn Hazard**

- Heater surfaces are hot for a period of time after the heater has been shut down.
- Allow the heater to cool before performing service, maintenance, or cleaning.
- Failure to follow this warning will result in burns causing injury.

**WARNING
Fire and Explosion Hazard**

- Do not disassemble or attempt to repair any heater components or gas train components.
- All component parts must be replaced if defects are found.
- Failure to follow this warning will result in fire or explosions, causing property damage, injury, or death.

1. Close the fuel supply valve to the heater and disconnect the electrical supply before servicing unless necessary for your service procedure.
2. Clean the heater's orifice with compressed air or a soft, dry rag. Do not use files, drills, broaches, etc. to clean the orifice hole. Doing so will enlarge the hole, causing combustion or ignition problems. Replace the orifice if it cannot be cleaned properly.

3. The high limit switches, HEAT/VENT switch, and thermostat can be tested by disconnecting the leads at the component, and jumpering the leads together:
 - Reconnect the electrical supply and open fuel supply valves.
 - If the heater lights, the component is defective and must be replaced.
 - Do not leave the jumper on or operate the heater if the part is defective. Replace the part immediately.
 - An alternate method for checking the components is to perform a continuity check.
4. The air proving switch must not be jumpered. If jumpered, the ignition control will not allow heater operation. Test the air proving switch for continuity. If defective, replace the switch.
5. Open the respective case panel for access to burner or fan related components.
6. Disconnect the electrical leads for the respective component.
7. For reassembly, reverse the respective service procedure. Ensure gas connections are tightened securely.
8. After servicing, start the heater to ensure proper operation and check for gas leaks.

MOTOR AND FAN WHEEL

1. Open louvered access panel opposite burner end of heater. Disconnect motor leads.
2. Remove screws securing motor mounting plate to housing.
3. Pull fan and motor assembly from housing.
4. Loosen set screws on fan wheel.
5. Pull fan wheel from motor shaft.
6. Remove the four nuts securing motor to mounting plate.

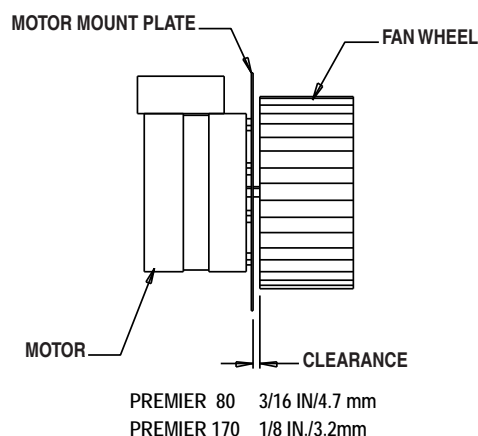
FIG. 16

AIR PROVING SWITCH

1. Open louvered case access panel.
2. Remove two sheet metal screws holding air proving switch blower housing. Remove assembly by turning switch assembly 90 degrees so the switch paddle can be pulled through oblong hole on side of fan housing. See Fig. 17.
3. Disconnect the leads from the air proving switch.
4. When installing replacement switch, use care in not bending the switch arm, otherwise ignition problems may occur.

FIG. 17

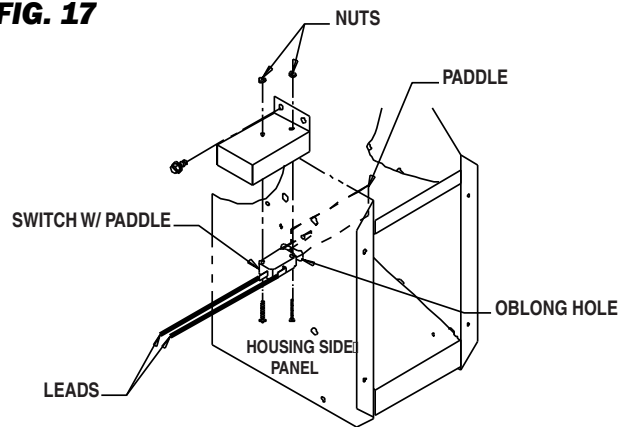

IGNITER AND FLAME SENSOR ASSEMBLY

1. See Fig. 18 or 19, depending on heater model, for location of igniter/sensor assembly.
 2. Remove the two screws securing the mounting bracket to the burner. Remove igniter assembly.
 3. Disconnect high voltage cable from igniter assembly.
 4. Remove the two screws that secure the igniter sensor to the mounting bracket.
- The igniter and ground rod should be cleaned to maintain proper ignition.
 - Use steel wool or emery cloth.
 - Rub briskly to remove buildup of dust, dirt, and oxide.
 - Check the igniter's ceramic base for cracks.
 - Replace the igniter if cracks are found.

FIG. 18
Premier 170

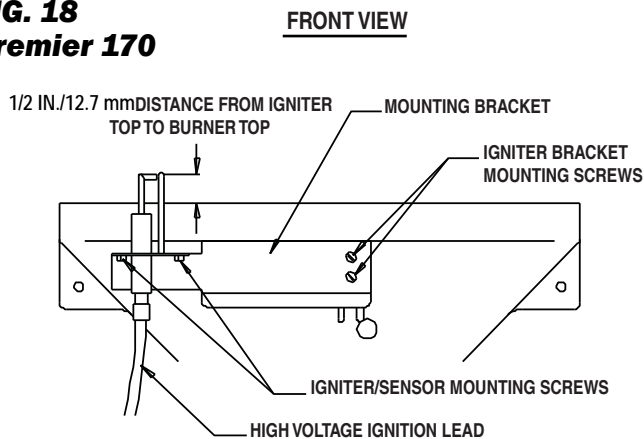

TOP VIEW

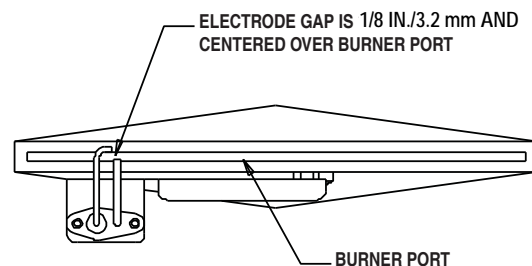
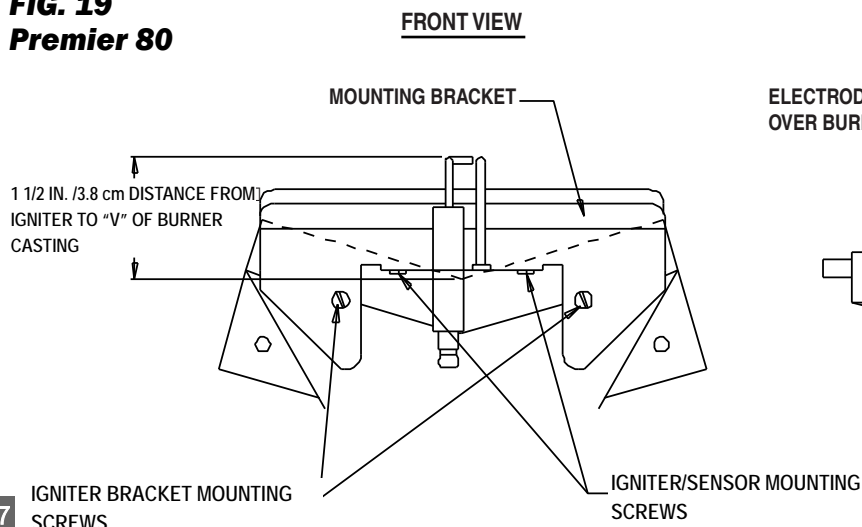
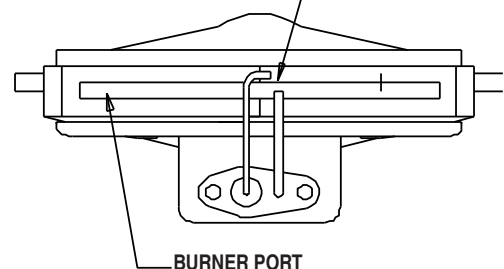

FIG. 19
Premier 80



TOP VIEW

ELECTRODE GAP IS: 1/8 in./3.2 mm AND CENTERED OVER BURNER PORT



BURNER PORT

TESTING THE MANUAL RESET HIGH LIMIT SWITCHES



WARNING

Fire Hazard

- Do not operate the heater with the high limit switch bypassed.
- Operating the heater bypassed high limit switch may lead to overheating, possibly resulting in a fire, with subsequent damage to the heater or property damage.

This heater has two limit switches, one on the heat chamber, the other on the fan housing. Both switches should be tested annually, typically when the heater is given a thorough cleaning.

1. Remove either high limit switch.
2. Holding the switch by one of its mounting legs, apply a small flame only to the sensing portion on the back of the switch. Be careful not to melt the plastic housing of the switch when conducting this test.
3. Within a minute, you should hear a pop coming from the switch, indicating the contacts of the switch have opened.

4. Allow the switch cool down for about a minute. Remove the red cap and firmly press the reset button on the switch.
5. Check for electrical continuity across the switch terminals to make sure the contacts have closed. Install red cap.

FIG. 20

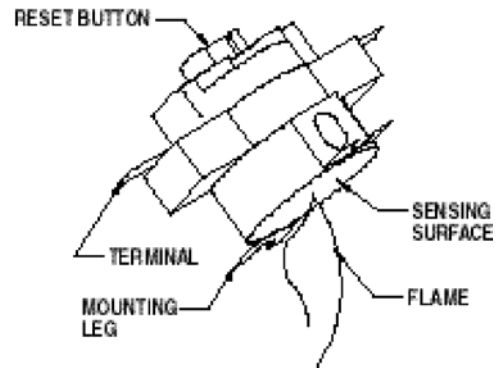

BURNER ORIFICE & GAS CONTROL VALVE

1. Open the burner end access door and remove gas hose from heater.
2. Remove the elbow and all screws at inlet of gas control valve. See Fig. 21.

FIG. 21



FIG. 22

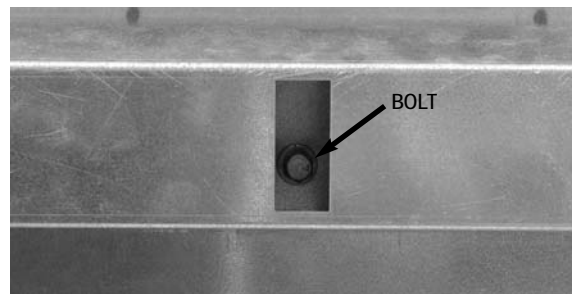
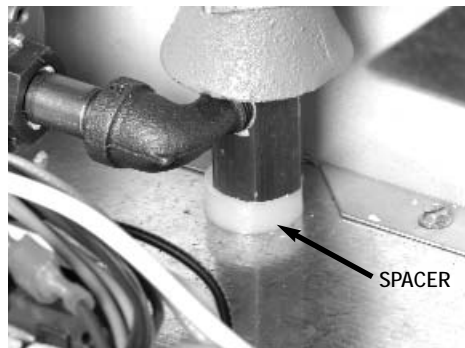

FIG. 23



3. Remove the burner retaining bolt at the underside of the heater's base. For Premier 170 heaters, the bolt is accessible through an opening in the heater's support leg. Use a ratchet with extension and 9/16 in. socket. See Fig. 22. For model TS080, also remove the spacer between heater base and burner. See Fig. 23.

- Pivot the gas control assembly to expose the burner orifice. See Fig. 24. Replace components as needed.

FIG. 24

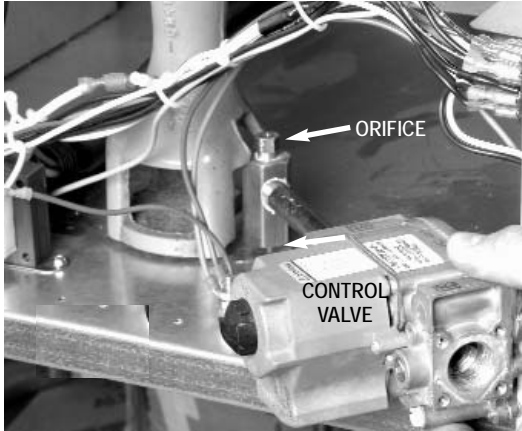

- When assembling the control valve to manifold, the valve must be offset 8 degrees from the orifice holder to ensure the control valve aligns to its mounting holes. See Fig. 25.

FIG. 25

Premier 80

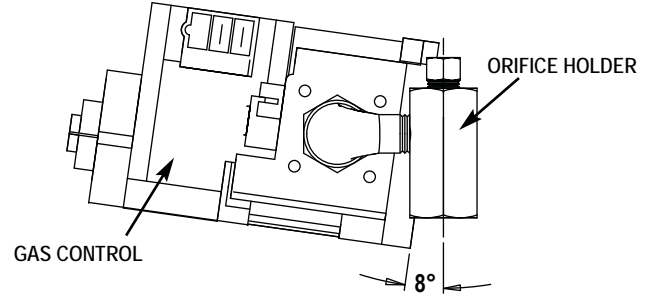

Premier 170

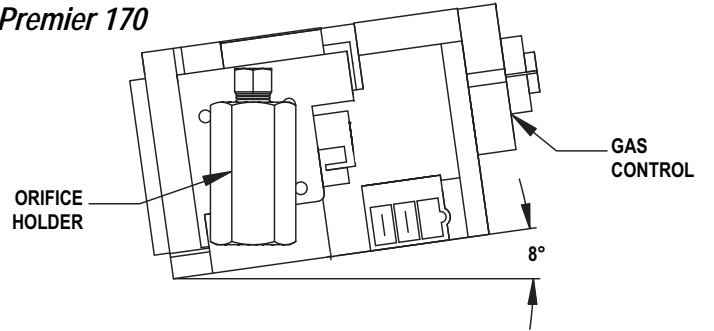

⚠ WARNING

- Do not disassemble the gas control valve.
- Do not attempt to replace any components of the gas control valve.
- The gas control valve must be replaced if any physical damage occurs to the control valve assembly.
- Failure to follow this warning will result in fire or explosions, leading to injury or death to humans, and property damage.

ATTENTION

- The following explains a typical procedure to be followed in checking gas pressures.
- The gas pressures will vary depending upon fuel type.
- Consult the dataplate on the heater or page 4 in this manual for specific pressures to be used in conjunction with this procedure.
- Gas pressure measured at the inlet to the gas valve is Inlet Pressure and gas pressure measured at the outlet of the gas valve is Burner Manifold Pressure.

A. Preparation

1. Obtain two pressure gauges capable of reading up to 35 In.W.C./8.7 kPa.
2. Disconnect the heater from the electrical supply and close the fuel supply valve to the heater inlet.
3. Open the burner access panel.
4. Brush or blow off any dust and dirt on or in the vicinity of the gas control valve.

B. Gauge Installation

1. Locate the inlet and outlet pressure taps. See Fig. 26. Remove the pressure tap plug using a 3/16 in. allen key.

FIG. 26

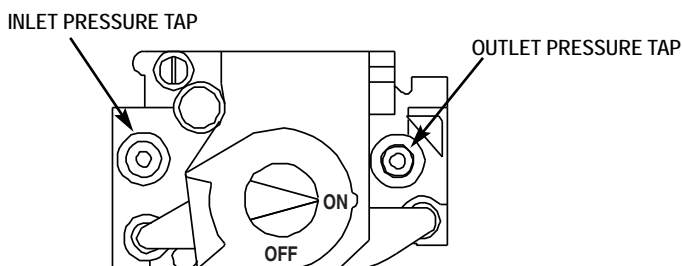

2. Securely connect a pressure gauge to each pressure tap.
3. Open the fuel supply valves to the heater and reconnect the heater electrical supply.
4. Start the heater

C. Reading Pressures

1. With the heater operating, the pressure gauges should read the pressures specified on the dataplate.
2. Do the readings at the inlet and outlet pressure gauges agree with that specified on the dataplate? If so, then no further checking or adjustment is required. Proceed to section D.
3. If the inlet pressures do not agree with that specified on the dataplate, then the regulator controlling gas pressure to the heater requires adjustment.
4. If the inlet pressures are correct and the burner manifold pressure does not agree with that specified on the dataplate, then the gas control valve's internal pressure regulator requires adjustment. See Fig. 27 for regulator location.

FIG. 27

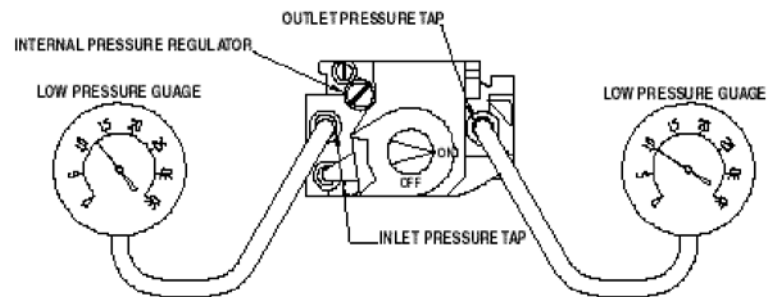

EXAMPLE SHOWS PRESSURE FOR PROPANE GAS
ALWAYS REFER TO PRESSURE ON DATAPLATE

D. Completion

1. Once the proper inlet and burner manifold pressures have been confirmed and/or properly set, close the fuel supply valve to the heater and allow the heater to burn off any gas remaining in the gas supply line.
2. Disconnect the heater from its electrical supply.
3. Remove the gauges and connecting hoses.
4. Install pressure tap plugs and tighten securely. Check for gas leaks.

Troubleshooting Information

READ THIS ENTIRE SECTION BEFORE BEGINNING TO TROUBLESHOOT PROBLEMS.



WARNING

- This heater can start at any time.
- Troubleshooting this system may require operating the unit with line voltage present and gas on. Use extreme caution when working on the heater.
- Failure to follow this warning may result in property damage, personal injury or death.

The following troubleshooting guide provides systematic procedures for isolating equipment problems. This guide is intended for use by a **QUALIFIED GAS HEATER SERVICE PERSON**. **DO NOT ATTEMPT TO SERVICE THESE HEATERS UNLESS YOU HAVE BEEN PROPERLY TRAINED.**

TEST EQUIPMENT REQUIRED

The following pieces of test equipment will be required to troubleshoot this system with minimal time and effort.

- **Digital Multimeter** - for measuring AC and DC voltage and resistance.
- **Low Pressure Gauge** - for checking inlet and outlet pressures at the gas control valve against dataplate rating.
- Visually inspect equipment for apparent damage.
- Check all wiring for loose connections and worn insulation.

Refer to the system operation sequence in this section to gain an understanding as to how the heater operates during a call for heat. Understanding the sequence of operation is important as it relates to problem solving.

Four green lights are located next to the selector switch. Each light will be activated in sequence as that circuit within the heater is verified by the ignition control. If the circuit is not verified, that respective light will not be activated. The most common heating mode problems are identified by a green light being OFF if a specific fault occurs. However, two other problems may also occur. See the following.

Identify the specific problem and then refer to the appropriate troubleshooting flow chart.

<u>Heating Mode Problems</u>	<u>Page</u>
Power status light not on	22
Transformer status light not on	22
Air proving status light not on	23
Gas control status light not on	24
All lights are on, but burner does not light	25
Heater lights but does not stay lit	26

<u>Ventilation Mode Problem</u>	<u>Page</u>
Motor Does Not Run	26

Components should be replaced only after each step has been completed and replacement is suggested in the flow chart. Refer to the Servicing sections as necessary to obtain information on disassembly and replacement procedures of the component once the problem is identified by the flow chart.

DIRECT IGNITION OPERATION SEQUENCE:

- The thermostat calls for heat.
 - Light activated indicating heater is receiving its main power supply.
- Line voltage is sent to selector switch.
- Selector switch sends line voltage to the transformer and to ignition control.
- Transformer reduces line voltage to 24 volts which is sent to ignition control.
 - Light is activated indicating that ignition control is receiving 24 volts from transformer.
- Ignition control module performs self safety check.
- Fan motor starts.
- Ignition control module sends 24 volts to air proving switch.
 - Internal components are tested.
 - Air proving circuit is checked and proven.
 - Light is activated indicating that the air proving circuit is operating properly.
- Ignition control module begins ignition trial sequence.
- Air proving switch closes and 24 volts are returned to the ignition control module.
- Ignition control module sends high voltage to the igniter electrode.
 - Igniter sparks.
- Ignition control module sends 24 volts to the gas control valve through the high limit switches.
 - Light is activated indicating that gas control valve is receiving 24 volts.
 - Gas control valve opens.
- Ignition occurs.
 - Igniter continues to spark until flame proving occurs.
 - Ignition spark is cut off.
 - Gas valve stays open.
- Room warms to desired temperature.
 - Thermostat is satisfied.
 - Heater shuts down.
- Process starts again on a call for heat.

IGNITION FAILURE SEQUENCE:

- There are three ignition trials. Each trial takes 10 seconds.
- If burner flame is not maintained at the end of the third trial, the module goes into safety lockout
 - Gas valve closes.
 - Ignition spark shuts off.
 - Fan motor stops.
- **To retry for ignition, the systems must be reset:**
 - Turn the thermostat down and then up to call for heat or unplug heater and plug it back in or
 - Position selector switch to off and then back to on.

HEATING MODE

All lights are ON → Normal Operation

Power status light not on →

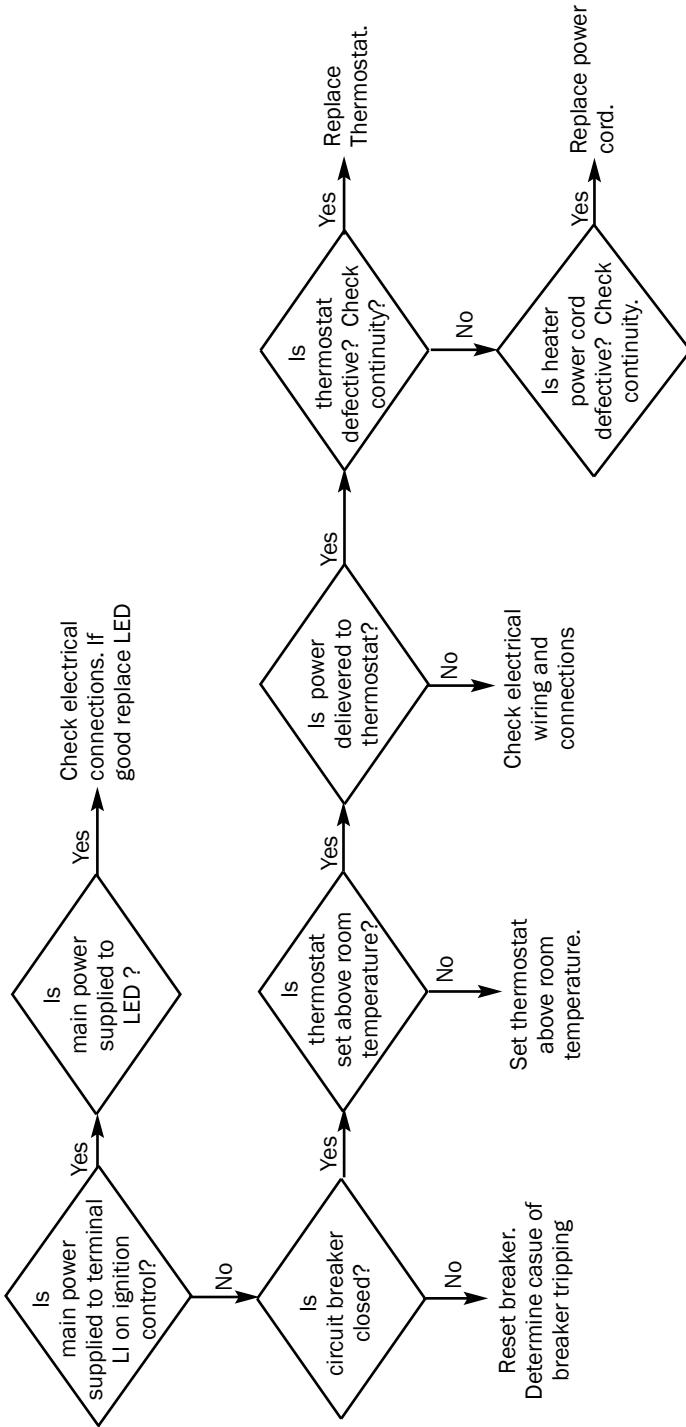

Transformer status light is not on.

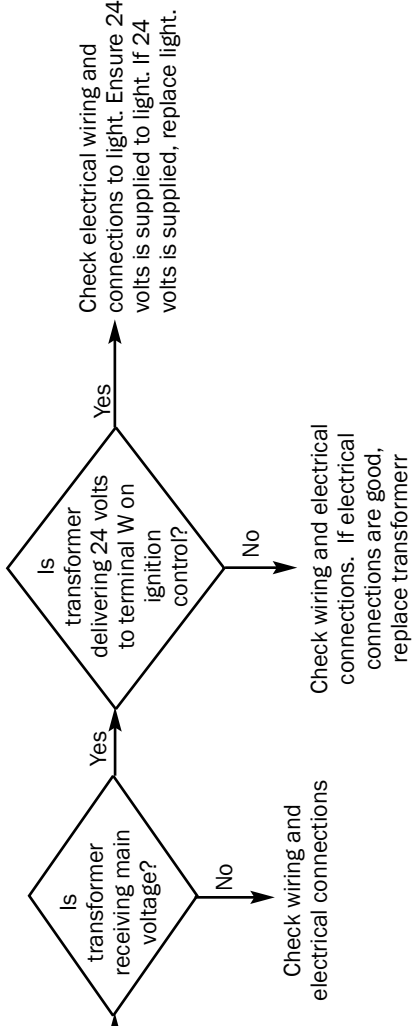

Air proving status light is not on.

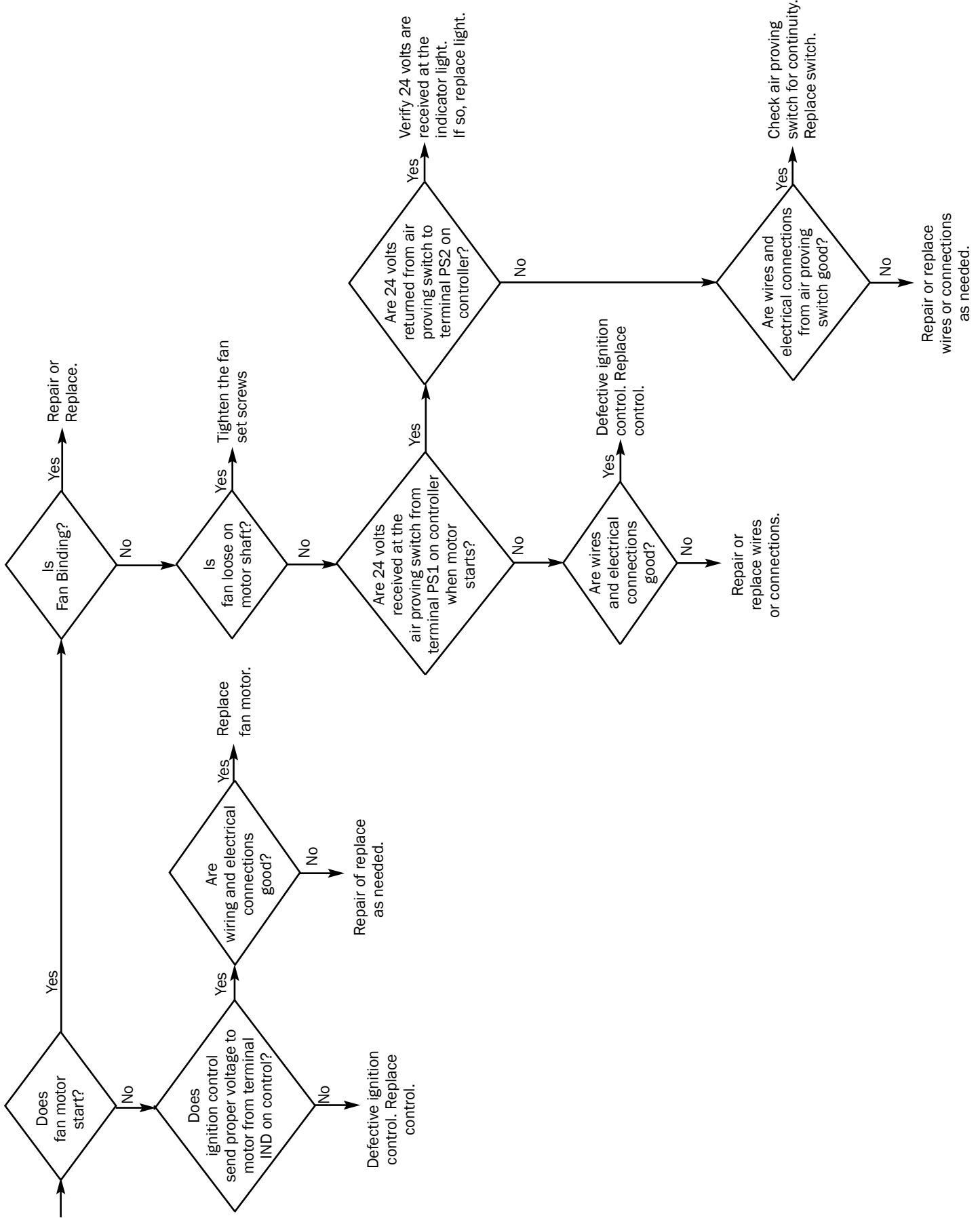

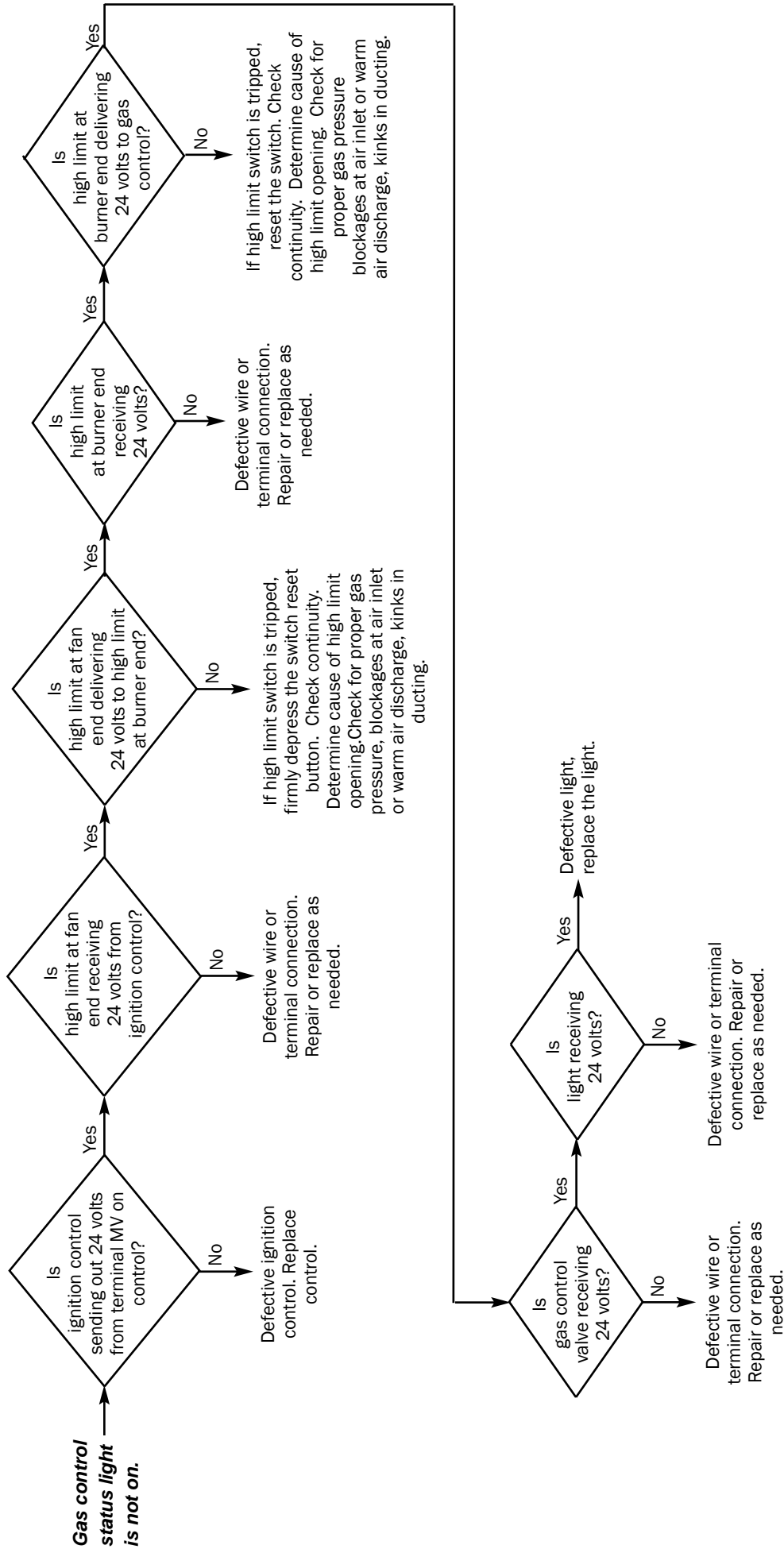

All lights are on, but burner does not light..

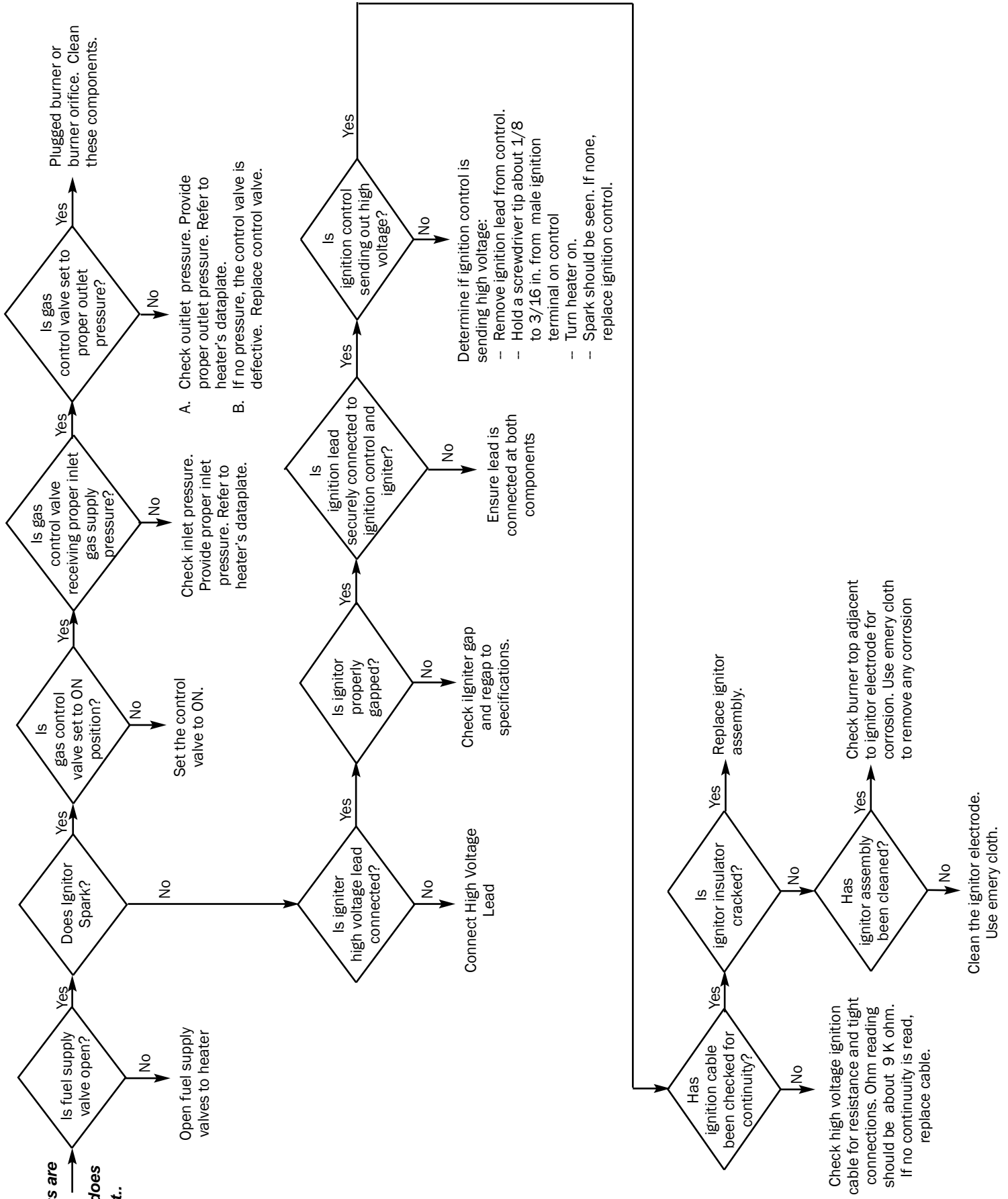

All lights are on. Heater lights but does not stay lit. → Caused by poor flame sense related problems. Check for cracked or dirty flame sensor, improperly positioned sensor, or poor heater and power supply grounds.

VENTILATION MODE

Problem
Motor Does Not Run →

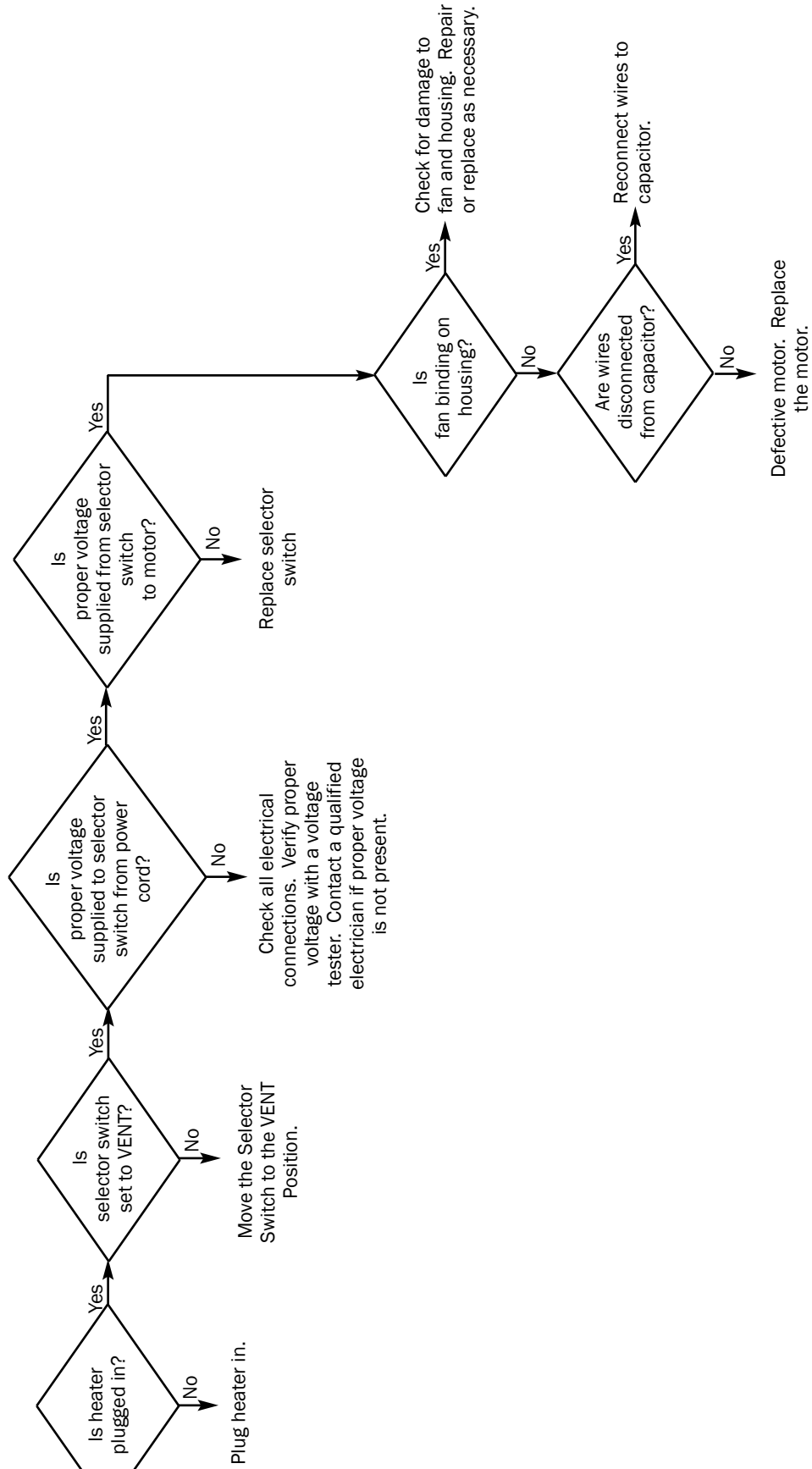

Electrical Connection and Ladder Diagram

PREMIER 80/170

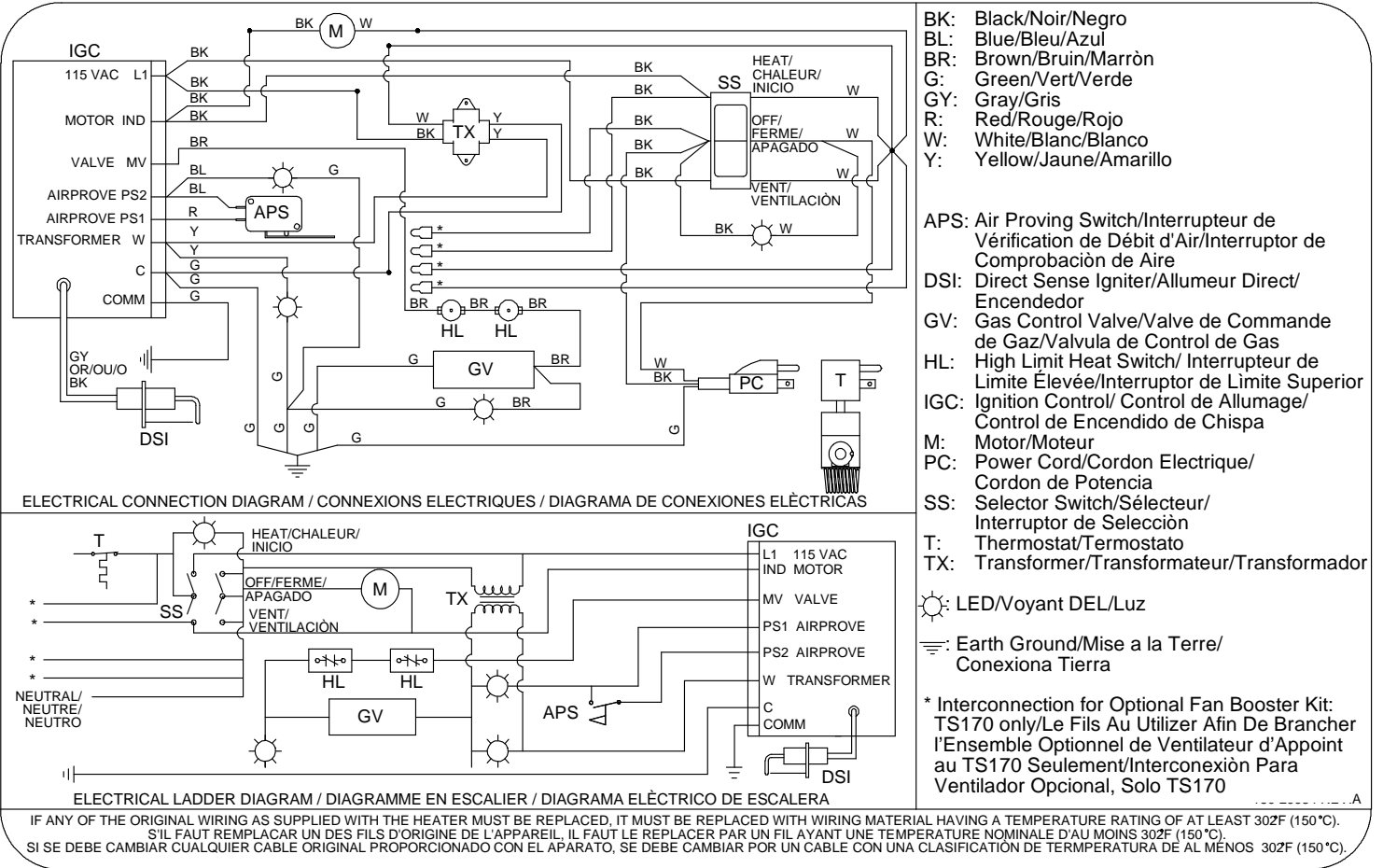

Heater Component Function

Air Proving Switch

Safety device used to insure that the proper air flow is being achieved before the gas valve is opened.

Burner

Cast iron component used to channel gas and provide an area at which the fuel may ignite.

Burner Orifice

Brass metering device used to feed gas to burner at a specific rate.

Direct Spark Ignition Control Module

Electronic printed circuit board which sends and receives voltages to various controls in an automatic ignition system. An important safety feature of the control board is that it will shut down the entire heater, thereby stopping the flow of fuel gas if burner flame goes out.

Fan Housing

Chamber used for delivering air for efficient air movement.

Fan Wheel

Component used in conjunction with the motor and fan housing to pull the hot air from heater and blow it into room for heating (also known as a squirrel cage).

Gas Control Valve

Electrical device consisting of a low pressure regulator and electrical solenoids used for the control of gas flow to the burner assembly. A feature of the control valve is a built-in gas shut off which may be used to isolate the heater from its gas supply when servicing.

Gas Hose

Flexible connector used to convey gas from supply line in building to heater.

Heat Chamber

Metal "fire box" within the appliance that provides an area where burner flame mixes with combustion air, thereby providing heat.

High Limit Switch

Safety device wired into the control system which is used to break an electrical circuit to the gas control valve in event of overheat situation.

Igniter

Ignition device used on automatic direct spark ignition control systems. Ignites gas by spark.

Motor

Electric device used to force preheated air through the heater and to circulate heat within a certain area. Converts electrical energy into mechanical energy.

Regulator

Mechanical device used in gas distribution systems to reduce a higher inlet pressure to a preset lower pressure. The regulator is responsible to supply a steady outlet pressure to the heater(s) despite changes in inlet pressure, heater demand and weather conditions.

Selector Switch

Electrical device which is used to allow the end user to use the heater in either a heating or ventilation application.

Status Light

A green light emitting diode (L.E.D.) wired into the electrical circuit. Provides an easily recognizable indication of heater operation.

Thermostat

Electrical device used as an automatic "on/off" switch which will respond to changes in temperature in a certain area. Can be wired so contacts in the thermostat open or close on temperature increase or decrease.

Transformer

Electrical control used to accept line power supply primary voltage and reduce it to lower secondary voltage to operate certain control systems.

Parts Identification

PREMIER 80 PARTS SCHEMATIC

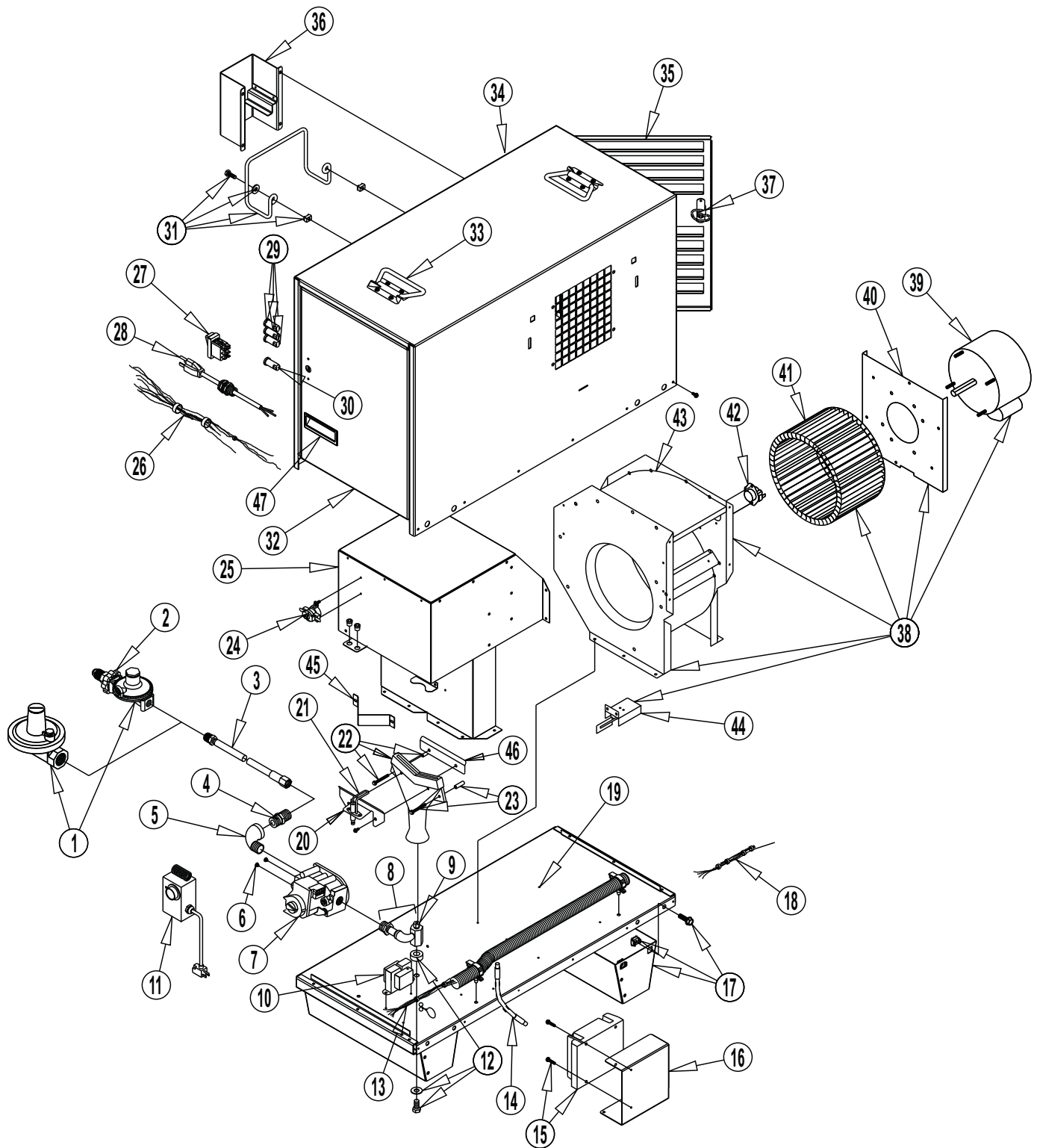

PREMIER 80 PARTS LIST

Item	Description		Part Number
1	Regulator	Propane Gas	26377
		Natural Gas	21999
2	Handwheel w/ Spring	Propane Gas	26395
3	Universal Hose Kit, 4.57 m. Hose w/ Adapters		24600
4	Adapter 1/2 NPT x 5/8 - 18		06655
5	EII		09309
6	Screw		09425
7	Valve, Gas Control	Propane Gas	522076
		Natural Gas	522078
8	Manifold Assembly w/ Orifice	Propane Gas	26391
		Natural Gas	26438
9	Orifice, Burner	Propane Gas	571625
		Natural Gas	571626
10	Transformer		26412
11	Thermostat Kit w/ 6.10 m.Cord		09454
12	Washer, Bolt, Spacer		25866
13	Harness, Wire, Burner End		26383
14	Wire, Igniter		25840
15	Control Ignition		25865
16	Bracket, Ignition Control		26411
17	Support Leg		26378
18	Harness, Wire, Motor End		26382
19	Base		26380
20	Bracket, Igniter/Sensor		571663
21	Igniter		571662
22	Burner		26484
23	Screws and Spacers		571211
24	Switch, High Limit, Burner End (275 °F)		503933
25	Chamber, Heat		571666
26	Harness, Wire, Status Lights		26381
27	Switch, Selector		26385
28	Cord, Power		26379
29	Light,Status, 24 Volt		26392
30	Light,Status, 120 Volt		26393
31	Hanger, Hose		571619
32	Door Assembly, Burner End	Propane Gas	573453
		Natural Gas	573454
33	Handle		571628
34	Case Assembly	Propane Gas	573455
		Natural Gas	573456
35	Door Assembly, Fan End		573457
36	Thermostat Bracket		26401
37	Latch, Door		26437
38	Fan Assembly		26384
39	Motor		520292
40	Motor Mount		571686
41	Fan		570304
42	Switch, High Limit, Fan End (250 °F)		571671
43	Housing, Fan		571612
44	Switch, Air Proving		26485
45	Bracket, Burner		571649
46	Bracket, Flame Arrestor		571609
47	Handle, Door Pull		26479

PREMIER 170 PART SCHEMATIC

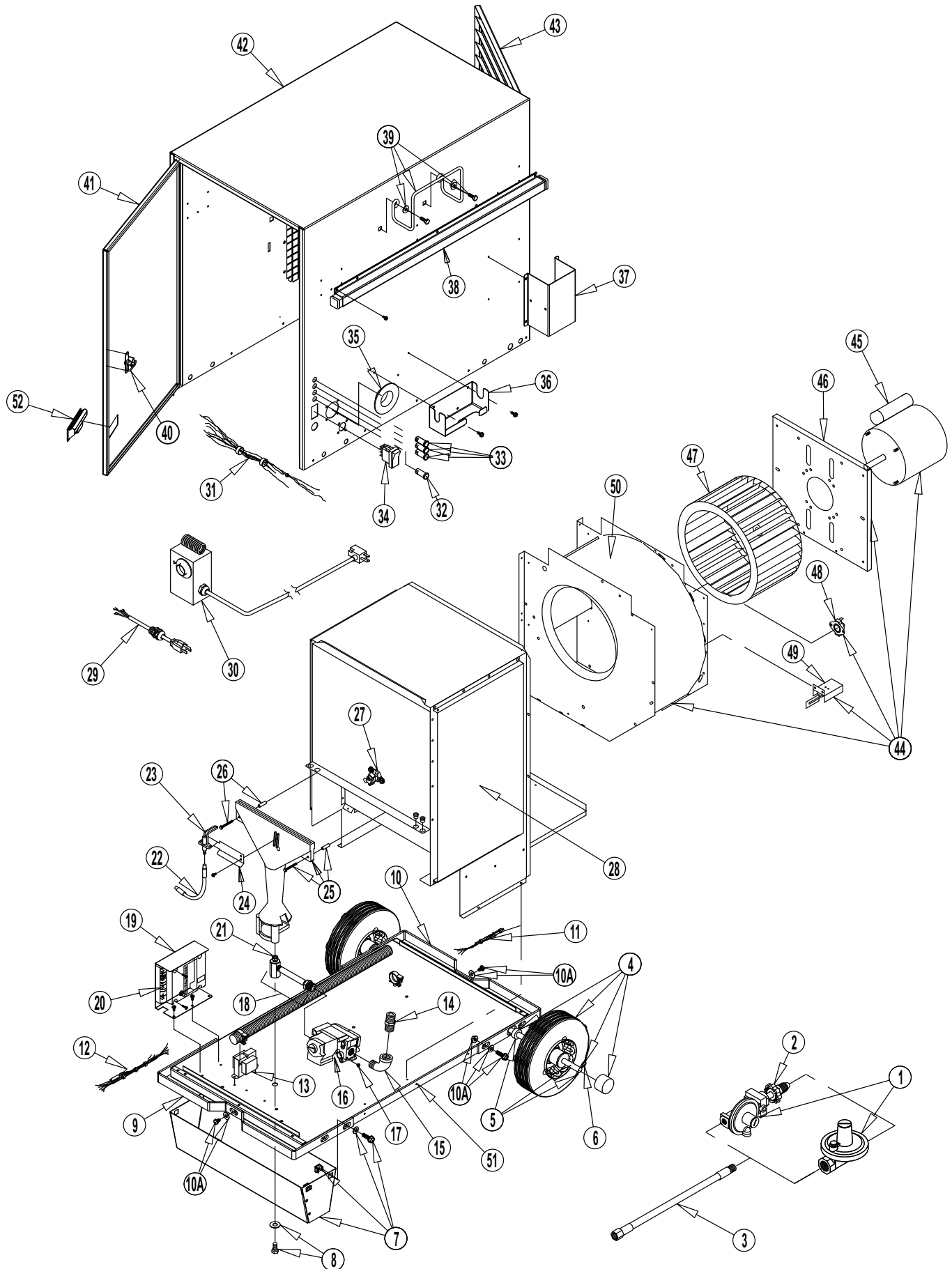

PREMIER 170 PARTS LIST

Item	Description		Part Number
1	Regulator	Propane Gas	26419
		Natural Gas	09795
2	Hand Wheel with Spring	Propane Gas	26395
3	Universal Hose Kit, 4.57m. Hose w/ Adapters		24600
4	Wheel Kit		26418
5	Axle		26415
6	Cotter Pin		26417
7	Kit, Leg Bracket		26413
8	Bolt and Washer		25866
9	Handle, Bracket, Burner End		26426
10	Handle, Bracket, Motor End		26427
10A	Nut, Bolt & Washer		26443
11	Wire Harness, Motor End		26406
12	Wire Harness, Burner and Gas Control End		26407
13	Transformer		26412
14	Adapter,Hose, 1/2 NPT x 5/8-18	Propane Gas	06655
		Natural Gas	25873
15	EII		09309
16	Valve, Gas Control	Propane Gas	522076
		Natural Gas	522078
17	Screw		09425
18	Manifold Assembly with Orifice	Propane Gas	26404
		Natural gas	26441
19	Bracket, Ignition Control		26410
20	Ignition Control		25865
21	Orifice	Propane Gas	21573
		Natural Gas	571624
22	Wire, Igniter		25840
23	Igniter		25841
24	Bracket, Igniter		25843
25	Burner with Mounting Hardware		25842
26	Burner Mounting Hardware		571211
27	Switch, High Limit, Burner End (275° F)		503933
28	Chamber, Heat		26403
29	Cord, Power		26379
30	Thermostat Kit w/ 20 ft. Cord		09454
31	Wire Harness, Status Lights		26408
32	Light,Status, 120 Volt		26393
33	Light,Status, 24 Volt		26392
34	Switch, Heat/Vent, Rocker		26385
35	Plug		25747
36	Bracket, Regulator Storage		26402
37	Bracket, Thermostat Storage		26401
38	Handle, Sliding		571760
39	Hanger, Hose		571619
40	Latch, Door		26437
41	Door, Burner End	Propane gas	573458
		Natural Gas	573459
42	Case Assembly	Propane Gas	573460
		Natural Gas	573461
43	Door, Louvered, Motor End		573462
44	Housing Assembly w/ Motor, Fan, High Limit and Air Proving Switches		26439

(Continued on page 34)

PREMIER 170 PARTS LIST (Continued)

Item	Description	Part Number
45	Motor	520169
46	Mount, Motor	25835
47	Fan	570481
48	Switch, High Limit, Motor End (190°F)	571400
49	Switch, Air Proving	09925
50	Housing, Fan	26440
51	Base	26414
52	Handle, Door	26479

Warranty Policy

HEATER

L.B. White Co., Inc. warrants that the component parts of its heater are free from defects in material and workmanship, when properly installed, operated, and maintained in accordance with the Installation and Maintenance Instructions, safety guides and labels contained with each unit. If, **within 24 months from the date of purchase by the end user**, any component is found to be defective, L.B. White Co., Inc. will at its option, repair or replace the defective part or heater, with a new part or heater, F.O.B., Onalaska, Wisconsin.

Registering your product online with L.B. White will automatically qualify a unit and its component parts for warranty consideration. If a product has not been registered with L.B. White, a copy of the bill of sale will be required to establish warranty qualification. If neither is available, the warranty period will be 24 months from date of shipment from L. B. White.

PARTS

L.B. White Co., Inc. warrants that replacement parts purchased from the company and used on the appropriate L. B. White equipment are free from defects both in material and workmanship for **24 months from the date of purchase by the end user**. Warranty is automatic if a component is found defective within 24 months of the date code marked on the part. If the defect occurs more than 24 months later than the date code but within 24 months from the date of purchase by the end user, a copy of a bill of sale will be required to establish warranty qualification.

duration to the duration of the applicable warranty stated above. The remedies set forth above are the sole and exclusive remedies available hereunder. L.B. White will not be liable for any incidental or consequential damages directly or indirectly related to the sale, handling or use of the equipment, and in any event L.B. White's liability in connection with the equipment, including for claims based on negligence or strict liability, is limited to the purchase price.

The warranty set forth above is the exclusive warranty provided by L.B. White, and all other warranties, including any implied warranties or merchantability or fitness for a particular purpose, are expressly disclaimed. In the event any implied warranty is not hereby effectively disclaimed due to operation of law, such implied warranty is limited in

Some states do not allow limitations on how long an implied warranty lasts, so the above limitation may not apply to you. Some states do not allow the exclusion or limitation of incidental or consequential damages, so the above limitation or exclusion may not apply to you. This warranty gives you specific legal rights, and you may also have other rights which vary from state to state.

To register your product and ensure full warranty, go to

http://www.lbwhite.com/customer_care_center/product-registration/. Please have the serial number(s) and model(s) handy for the products you are registering.

Replacement Parts and Service

Contact your local L.B. White dealer for replacement parts and service. You may also call the L.B. White Co., Inc. at 1-800-345-7200, for assistance, or email us at customerservice@lbwhite.com.

Be sure that you have your heater model number and configuration number when calling.