



An Oshkosh Corporation Company

---

# ***Operation and Safety Manual***

*Original Instructions - Keep this manual with the machine at all times.*

***Models***

***12SP***

***15SP***

***ANSI***



**3120774**

*June 29, 2018 - Rev N*

---



## **WARNING**

Operating, servicing and maintaining this vehicle or equipment can expose you to chemicals including engine exhaust, carbon monoxide, phthalates, and lead, which are known to the State of California to cause cancer and birth defects or other reproductive harm. To minimize exposure, avoid breathing exhaust, do not idle the engine except as necessary, service your vehicle or equipment in a well-ventilated area and wear gloves or wash your hands frequently when servicing. For more information go to [www.P65Warnings.ca.gov](http://www.P65Warnings.ca.gov).

## **FOREWORD**

This manual is a very important tool! Keep it with the machine at all times.

The purpose of this manual is to provide owners, users, operators, lessors, and lessees with the precautions and operating procedures essential for the safe and proper machine operation for its intended purpose.

Due to continuous product improvements, JLG Industries, Inc. reserves the right to make specification changes without prior notification. Contact JLG Industries, Inc. for updated information.

## **SAFETY ALERT SYMBOLS AND SAFETY SIGNAL WORDS**



This is the Safety Alert Symbol. It is used to alert you to the potential personal injury hazards. Obey all safety messages that follow this symbol to avoid possible injury or death

### **⚠ DANGER**

INDICATES AN IMMINENTLY HAZARDOUS SITUATION. IF NOT AVOIDED, WILL RESULT IN SERIOUS INJURY OR DEATH. THIS DECAL WILL HAVE A RED BACKGROUND.

### **⚠ WARNING**

INDICATES A POTENTIALITY HAZARDOUS SITUATION. IF NOT AVOIDED, COULD RESULT IN SERIOUS INJURY OR DEATH. THIS DECAL WILL HAVE AN ORANGE BACKGROUND.

### **⚠ CAUTION**

INDICATES A POTENTIALITY HAZARDOUS SITUATION. IF NOT AVOIDED, MAY RESULT IN MINOR OR MODERATE INJURY. IT MAY ALSO ALERT AGAINST UNSAFE PRACTICES. THIS DECAL WILL HAVE A YELLOW BACKGROUND.

### **NOTICE**

INDICATES INFORMATION OR A COMPANY POLICY THAT RELATES DIRECTLY OR INDIRECTLY TO THE SAFETY OF PERSONNEL OR PROTECTION OF PROPERTY.

## SECTION - SAFETY ALERT SYMBOLS AND SAFETY SIGNAL WORDS

---

### **WARNING**

THIS PRODUCT MUST COMPLY WITH ALL SAFETY RELATED BULLETINS. CONTACT JLG INDUSTRIES, INC. OR THE LOCAL AUTHORIZED JLG REPRESENTATIVE FOR INFORMATION REGARDING SAFETY RELATED BULLETINS WHICH MAY HAVE BEEN ISSUED FOR THIS PRODUCT.

### **NOTICE**

JLG INDUSTRIES, INC. SENDS SAFETY RELATED BULLETINS TO THE OWNER OF RECORD OF THIS MACHINE. CONTACT JLG INDUSTRIES, INC. TO ENSURE THAT THE CURRENT OWNER RECORDS ARE UPDATED AND ACCURATE.

### **NOTICE**

JLG INDUSTRIES, INC. MUST BE NOTIFIED IMMEDIATELY IN ALL INSTANCES WHERE JLG PRODUCTS HAVE BEEN INVOLVED IN AN ACCIDENT INVOLVING BODILY INJURY OR DEATH OF PERSONNEL OR WHEN SUBSTANTIAL DAMAGE HAS OCCURRED TO PERSONAL PROPERTY OR THE JLG PRODUCT.

### **For :**

- Accident Reporting
- Product Safety Publications
- Current Owner Updates
- Questions Regarding Product Safety
- Standards and Regulations Compliance Information
- Questions Regarding Special Product Applications
- Questions Regarding Product Modifications

### **Contact :**

Product Safety and Reliability Department  
JLG Industries, Inc.  
13224 Fountainhead Plaza  
Hagerstown, MD 21742

or Your Local JLG Office  
(See addresses on manual rear cover)

### **In USA:**

Toll Free: 877-JLG-SAFE (877-554-7233)

### **Outside USA:**

Phone: 240-420-2661  
E-mail: [ProductSafety@JLG.com](mailto:ProductSafety@JLG.com)

**REVISION LOG**

Original Issue	A - April 4, 1999
Revised	B - March 7, 2000
Revised	C - April 13, 2000
Revised	D - April 20, 2000
Revised	E - January 16, 2002
Revised	F - January 20, 2006
Revised	G - July 12, 2006
Revised	H - July 23, 2008
Revised	I - November 26, 2008
Revised	J - December 7, 2010
Revised	K - May 3, 2011
Revised	L - May 4, 2012
Revised	M - March 23, 2015
Revised	N - June 29, 2018 - Revised Covers, Prop 65

## TABLE OF CONTENTS

SECTION - PARAGRAPH, SUBJECT	PAGE
FOREWORD .....	A
SAFETY ALERT SYMBOLS AND SAFETY SIGNAL WORDS ..	B
Contact: .....	C
In USA: .....	C
Outside USA: .....	C
REVISION LOG	
<b>SECTION - 1 - SAFETY PRECAUTIONS</b>	
1.1 GENERAL .....	1-1
1.2 PRE-OPERATIONAL SAFETY .....	1-2
1.3 OPERATING SAFETY .....	1-3
1.4 ELECTROCUTION HAZARD .....	1-7
1.5 TRANSPORTING .....	1-8
1.6 TRANSPORT SAFETY .....	1-8
<b>SECTION - 2 - USER RESPONSIBILITIES, MACHINE PREPARATION, AND INSPECTION</b>	
2.1 PERSONNEL TRAINING .....	2-1
Operator Training .....	2-1
Training Supervision .....	2-1
Operator Responsibility .....	2-1
2.2 PREPARATION, INSPECTION, AND MAINTENANCE ..	2-2
Pre-Start Inspection .....	2-4

SECTION - PARAGRAPH, SUBJECT	PAGE
2.3 FUNCTION CHECK .....	2-4
2.4 DAILY WALK-AROUND INSPECTION .....	2-5
General .....	2-5
Batteries Charged .....	2-7
Overall Cleanliness .....	2-7
Placards .....	2-7
Lubrication .....	2-7
<b>SECTION - 3 - MACHINE CONTROLS AND INDICATORS</b>	
3.1 OPERATING CHARACTERISTICS AND LIMITATIONS	3-1
General .....	3-1
Placards .....	3-1
Capacities .....	3-1
Stability .....	3-1
3.2 CONTROLS AND INDICATORS .....	3-2
Ground Control Station .....	3-2
Platform Control Station .....	3-4
Decal Installation .....	3-5
<b>SECTION - 4 - MACHINE OPERATION</b>	
4.1 MACHINE DESCRIPTION .....	4-1
4.2 GENERAL .....	4-2
4.3 BATTERY CHARGING .....	4-2

## TABLE OF CONTENTS

SECTION - PARAGRAPH, SUBJECT	PAGE
Battery Charger Operation . . . . .	4-2
Abnormal Cycle Indicator LED . . . . .	4-4
4.4 MACHINE SET-UP AND OPERATION . . . . .	4-7
Floor Stop Operation . . . . .	4-7
Raising and Lowering the Platform . . . . .	4-8
4.5 PLATFORM CONFIGURATIONS . . . . .	4-9
Platform Loading . . . . .	4-9
StockPicking Platform Operation . . . . .	4-10
Extendible Platform Operation - OPTION . . . . .	4-11
Extendible Platform - Lanyard Attachment . . . . .	4-12
Side Entry Platform with Material Tray - OPTION . . . . .	4-13
Platform Gate Alarm - OPTION . . . . .	4-13
4.6 QUICK-CHANGE PLATFORM MOUNTING . . . . .	4-14
Platform Removal . . . . .	4-14
Platform Installation . . . . .	4-14
4.7 STOWING MACHINE . . . . .	4-15
4.8 TRANSPORTING, LIFTING AND TIE DOWN . . . . .	4-15
General . . . . .	4-15
Transporting by Pushing . . . . .	4-15
Lifting . . . . .	4-16
Transport Vehicle Tie Down . . . . .	4-16
4.9 RUG CARRIER ACCESSORY (OPTION) . . . . .	4-17
General . . . . .	4-17
Pre-Start Inspection . . . . .	4-17

SECTION - PARAGRAPH, SUBJECT	PAGE
Hanging a Rug using the Rug Carrier	
Accessory Arms . . . . .	4-18
Removing a Rug using Rug Carrier	
Accessory Arms . . . . .	4-19

### SECTION - 5 - OPTIONAL EQUIPMENT

5.1 OPTIONAL EQUIPMENT . . . . .	5-1
Extra Power Pack (DC Battery, Charger & Case) . . . . .	5-1
Lifting Hook . . . . .	5-1
Platform Auxiliary Power Lowering Device . . . . .	5-1
Amber Beacon Light . . . . .	5-1
Platform Motion Alarm . . . . .	5-1
Foot-Operated Platform Controller . . . . .	5-1
Rug Carrier Accessory . . . . .	5-1
Machine Cycle Counter Meter . . . . .	5-2
Platform Gate Alarm . . . . .	5-2

### SECTION - 6 - EMERGENCY PROCEDURES

6.1 GENERAL INFORMATION . . . . .	6-1
6.2 EMERGENCY OPERATION . . . . .	6-1
Operator Unable to Control Machine . . . . .	6-1
Platform Caught Overhead . . . . .	6-1
6.3 INCIDENT NOTIFICATION . . . . .	6-1



## TABLE OF CONTENTS

<b>SECTION - PARAGRAPH, SUBJECT</b>	<b>PAGE</b>	<b>SECTION - PARAGRAPH, SUBJECT</b>	<b>PAGE</b>
<b>SECTION - 7 - GENERAL SPECIFICATIONS AND OPERATOR MAINTENANCE</b>		<b>LIST OF FIGURES</b>	
7.1 INTRODUCTION .....	7-1	1-1. Read Your Manual. ....	1-2
7.2 GENERAL SPECIFICATIONS .....	7-2	1-2. Always Look in the Direction of Movement. Watch for Overhead and Other Obstructions. ...	1-4
Machine Specifications .....	7-2	1-3. Death or Serious Injury Could Occur from a Tip Over .....	1-4
Electrical Specifications .....	7-3	1-4. All Personnel Must Stand Clear When Platform Is Being Raised Or Lowered. ....	1-5
Machine Component Weights .....	7-5	1-5. Falling from Platform could cause Death or Serious Injury .....	1-6
Serial Number Locations .....	7-5	1-6. Use Handles Provided On Mast Crossbar To Move Machine .....	1-9
7.3 OPERATOR MAINTENANCE .....	7-6	1-7. Do Not Move Unit on Soft or Uneven Surfaces or Over Obstructions, Bumps, Debris, Etc. ....	1-9
Battery .....	7-6	1-8. Two People May Be Required on Slopes Up To Five Degrees. Also Always Travel With Platform End On The Low Side of Slope. ....	1-10
Lubrication .....	7-7	2-1. Daily Walk-Around Inspection. ....	2-6
Lubrication Points .....	7-8	3-1. Ground Control Station .....	3-2
7.4 SUPPLEMENTAL INFORMATION .....	7-10	3-2. Manual Descent Valve Location .....	3-3
<b>SECTION - 8 - INSPECTION AND REPAIR LOG</b>		3-3. Platform Control Station .....	3-4
		3-4. SP Machine - Decal Installation .....	3-5
		4-1. Battery Box and Charger Assembly - (Original Design) .....	4-3

## TABLE OF CONTENTS

SECTION - PARAGRAPH, SUBJECT	PAGE
4-2. Battery Box and Charger Assembly - (Compact Design) . . . . .	4-3
4-3. Battery Charger - Front Panel - 120V-AC Input . .	4-5
4-4. Battery Charger - Front Panel - 120 - 240V-AC Input . . . . .	4-6
4-5. Engaging & Releasing Floor Stop . . . . .	4-8
4-6. Platform Operating Configurations. . . . .	4-10
4-7. Platform Operating Configurations. . . . .	4-11
4-8. SP Tie Down Pockets. . . . .	4-17

SECTION - PARAGRAPH, SUBJECT	PAGE
------------------------------	------

### LIST OF TABLES

1-1	Minimum Approach Distance (M.A.D.) . . . . .	1-7
2-1	Inspection and Maintenance Table . . . . .	2-3
3-1	SP Series Decal Installation Chart. . . . .	3-6
4-1	Maximum Platform Capacity. . . . .	4-9
7-1	Lubrication Specifications . . . . .	7-7
7-2.	Lubrication Intervals for Various Components . . .	7-9
8-1	Inspection and Repair Log. . . . .	8-1

## SECTION 1. SAFETY PRECAUTIONS

### 1.1 GENERAL

This section prescribes the proper and safe practices for major areas of machine usage which have been divided into three basic categories: Transporting, Pre-Operation and Operation. In order to promote proper usage of the machine, it is mandatory that a daily routine be established based on instruction given in this section. A maintenance program must also be established by a qualified person and must be followed to ensure that the machine is safe to operate.

The user/operator of the machine should not accept operating responsibility until this manual has been READ and UNDERSTOOD, and operating instructions of the machine under the supervision of an experienced and qualified operator, has been completed. If there is a question on application and/or operation, JLG Industries Product Safety and Reliability Department should be consulted.

#### **WARNING**

**MODIFICATION OF THE MACHINE WITHOUT APPROVAL OF JLG INDUSTRIES INC., OR CERTIFICATION BY A NATIONALLY RECOGNIZED TESTING LAB TO BE IN CONFORMITY WITH APPLICABLE OSHA REGULATIONS, AND TO BE AT LEAST AS SAFE AS BEFORE MODIFICATION, IS PROHIBITED AND IS A VIOLATION OF OSHA RULES.**

### 1.2 PRE-OPERATIONAL SAFETY

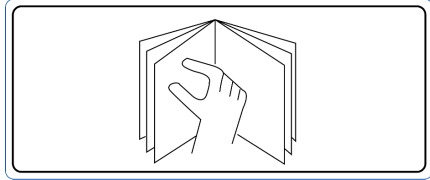

**Figure 1-1. Read Your Manual.**

- Read your manual. understand what you've read - then begin operations.
- Allow only those authorized and qualified personnel to operate machine who have demonstrated that they understand safe and proper operation and maintenance of the unit.
- An operator must not accept operating responsibilities until adequate training has been given by competent and authorized persons.
- Before operation check work area for overhead electric lines. (see *electrocution hazard*, section 1-2.)
- Before operation check work area for machine traffic such as forklifts, cranes, and other construction equipment.
- Set-up machine for operation only on a smooth, firm level surface.
- Ensure that operators of other overhead and floor level machines are aware of the aerial platforms presence. Disconnect power to overhead cranes, barricade floor area if necessary.
- Precautions to avoid all known hazards in the work area must be taken by the operator and his supervisor before starting the work.
- Do not operate this machine unless it has been serviced and maintained according to the manufacturers specifications and schedule.
- Ensure daily inspection and function check is performed prior to placing machine into operation. Have authorized personnel take any necessary corrective action before placing machine into operation.
- Never disable or modify any safety device. Any modification of the machine is a safety violation and is a violation of osha and ansi rules.
- Do not operate machine when exposed to high wind, rain or snow.
- Never operate or raise platform when machine is on a truck or other vehicle.

- Approved head gear (i.e. hard hat, etc.) must be worn when required by all operating and ground personnel.
- Read and obey all danger, warnings, cautions and operating instructions on machine and in this manual.
- Be familiar with location and operation of ground station and emergency controls.

### 1.3 OPERATING SAFETY

- Do not operate any machine on which danger, warning, caution or instruction placards or decals are missing or illegible.
- Never exceed manufacturers rated platform capacity - refer to capacity decal on machine.
- Do not enter platform until the floor brake has been properly adjusted and the unit's base frame is level according to the bubble level indicator on base frame.
- Do not operate machine on soft footing that will allow the floor brake to settle into or break through surface.
- Never operate a malfunctioning machine. If a malfunction occurs, shut down the machine, remove it from service, and notify proper authorities.
- While operating the machine, personnel in the platform shall at all times wear approved fall protection equipment and other safety gear as required. A lanyard attachment is supplied on the top rail at the rear of the platform. Failure to follow these instructions could result in death or serious injury.
- Check clearances above, on sides and bottom of platform when raising and lowering platform.
- Never use the mast to gain access to or leave platform.

## SECTION 1 - SAFETY PRECAUTIONS

---

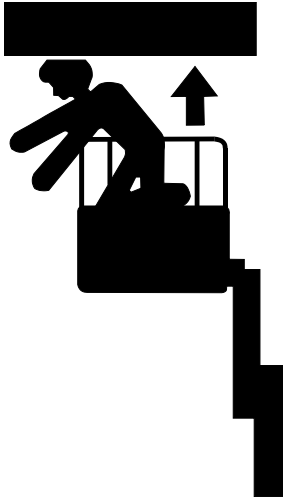

**Figure 1-2. Always Look in the Direction of Movement.  
Watch for Overhead and Other Obstructions.**

- Do not attach overhanging loads to the platform or increase the platform size with unauthorized deck extensions or attachments.
- Do not tie off machine to any adjacent structure. never attach wire, cable or any similar items to platform.

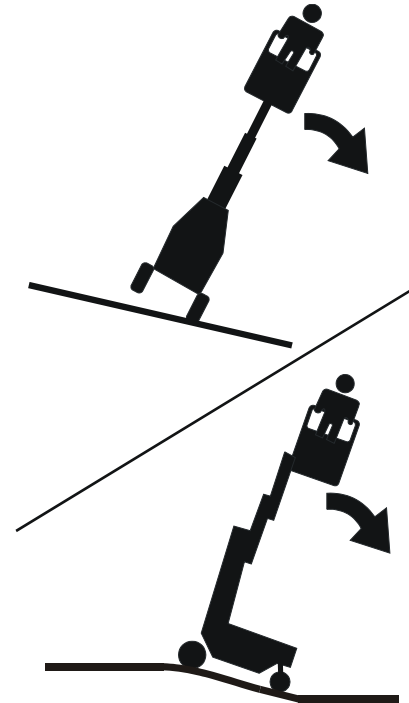

**Figure 1-3. Death or Serious Injury Could Occur from a  
Tip Over**



**Figure 1-4. All Personnel Must Stand Clear When Platform Is Being Raised Or Lowered.**

- Transfers between a structure and the platform expose operators to fall potentials. this practice should be discouraged wherever possible. Where transfer must be accomplished to perform the job, two lanyards will be used and the platform must be within 1 foot (0.3 m) of the adjacent - safe and secure - structure. one lanyard should be attached to the platform, the other to the structure. The safety lanyard that is attached to the platform should not be disconnected until such time as the transfer to the structure is complete.
- No horseplay is permitted in platform.
- Do not allow personnel to tamper with, service, or operate this machine from the ground with personnel in platform except in an emergency.
- During platform operation keep all body parts inside platform railings.
- Never position ladders, steps, or similar items on unit to provide additional reach for any purpose.
- When working from platform both feet must be firmly positioned on deck.
- Do not extend reach limits of this machine with additional equipment such as planks, boxes, etc.

## SECTION 1 - SAFETY PRECAUTIONS

---



**Figure 1-5. Falling from Platform could cause Death or Serious Injury.**

- Always ensure that power tools are properly stowed and never left hanging by their cord from the platform work area.
- Avoid accumulation of debris on platform work area. keep mud, oil, grease and other slippery substances from footwear and platform deck.

- Do not use ladders on or against machine. do not perform work that will subject unit to a horizontal force or create a rocking motion of the platform.
- Do not operate machine without the platform gates securely latched.



**1.4 Electrocutation Hazard**

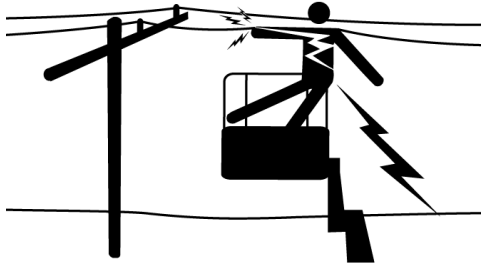

**Table 1-1. Minimum Approach Distance (M.A.D.)**

<b>VOLTAGE RANGE (PHASE TO PHASE)</b>	<b>MINIMUM APPROACH DISTANCE - Feet (m)</b>
0-50KV	10 (3)
Over 50KV to 200KV	15 (5)
Over 200KV to 350KV	20 (6)
Over 350KV to 500KV	25 (8)
Over 500KV to 750KV	35 (11)
Over 750KV to 1000KV	45 (14)
<b>NOTE:</b> <i>This Minimum Approach Distance shall apply except where employer, local, or governmental regulations are more stringent.</i>	

Maintain a clearance of at least 10 ft (3m) between any part of the machine and its occupants, their tools, and their equipment from any electrical line or apparatus carrying up to 50,000 volts. One foot (0.3m) additional clearance is required for every additional 30,000 volts or less.

The minimum approach distance may be reduced if insulating barriers are installed to prevent contact, and if the barriers are rated for the voltage of the line being guarded. These barriers shall not be part of (or attached to) the machine. The minimum approach distance shall be reduced to a distance within the designed working dimensions of the insulating barrier. This determination shall be made by a qualified person in accordance with employer, local, or governmental requirements for work practices near energized equipment.

## SECTION 1 - SAFETY PRECAUTIONS

---

### 1.5 TRANSPORTING

Before transporting the machine the user/operator must be familiar with the proper procedures for transporting the machine, as well as the weight and size of the machine.

The user/operator should be familiar with the surrounding work area and surface before transporting the machine. The work area must be a smooth, firm surface on which machine is capable of being leveled.

**NOTE:** *Remember that the key to safe and proper usage is common sense and its careful application.*

#### **WARNING**

**FAILURE TO COMPLY WITH SAFETY PRECAUTIONS LISTED IN THIS SECTION AND ON MACHINE MAY RESULT IN MACHINE DAMAGE, PERSONNEL INJURY OR DEATH AND IS A SAFETY VIOLATION.**

### 1.6 TRANSPORT SAFETY

- Fully lower and completely empty platform of tools and debris before moving machine.
- Never allow personnel in platform while moving machine.

#### **WARNING**

**FAILURE TO OBSERVE THE FOLLOWING TIPPING HAZARD INSTRUCTIONS COULD CAUSE THE UNIT TO TIP OVER OR BE HARD TO CONTROL WHEN BEING MOVED, WHICH COULD RESULT IN SERIOUS INJURY OR DEATH DUE TO BEING PINNED OR CRUSHED BY THE UNIT.**

- On a level surface, always travel with the platform end leading the way.
- Watch for obstructions around machine and overhead when moving.
- Check travel path for persons, holes, bumps, drop-offs, obstructions, debris, and coverings which may conceal holes and other hazards, as tipping could occur.
- Before moving machine on floors, trucks and other surfaces, check allowable capacity of surfaces.
- Two people are required on slopes up to 5 degrees. a forklift must be used when moving units on slopes greater than 5 degrees.



**Figure 1-6. Use Handles Provided On Mast Crossbar To Move Machine.**

- Always travel up or down a slope with the platform end of the machine positioned towards the low side of the slope. the operator and assistant must walk beside and guide the machine with the handles on the mast crossbar.
- Never position the unit sideways on a slope.
- Use caution and check clearances when moving machine in restricted or close quarters.



**Figure 1-7. Do Not Move Unit on Soft or Uneven Surfaces or Over Obstructions, Bumps, Debris, Etc.**

- Always use an assistant when moving machine in areas where vision is obstructed.
- Keep non-operating personnel at least 6 feet (1.8 m) away from machine during transporting operations.

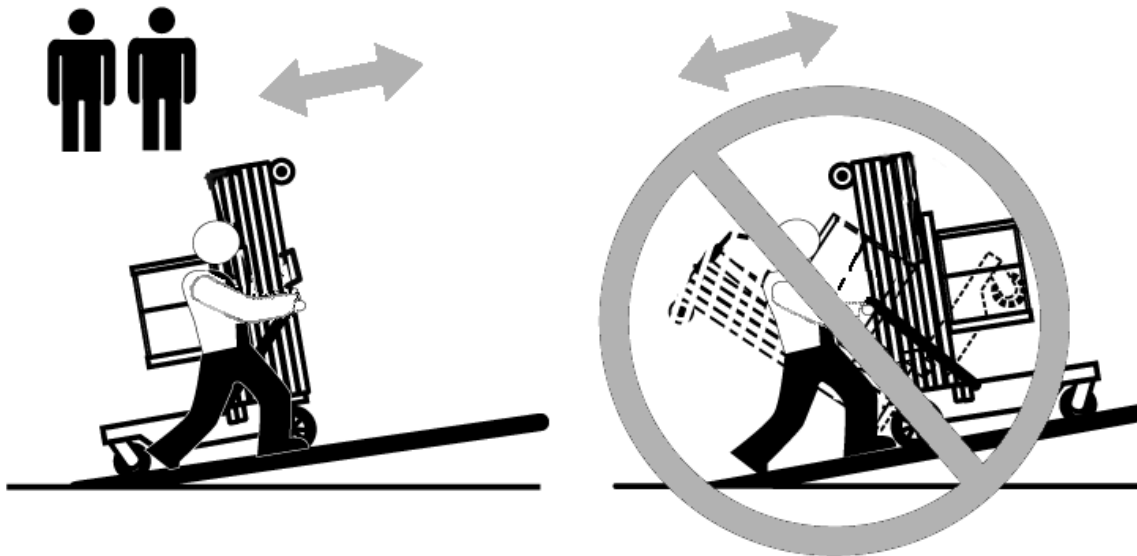

**Figure 1-8. Two People May Be Required on Slopes Up To Five Degrees.  
Also Always Travel With Platform End On The Low Side of Slope.**

## **SECTION 2. USER RESPONSIBILITIES, MACHINE PREPARATION, AND INSPECTION**

### **2.1 Personnel Training**

The aerial platform is a personnel handling device; so it is necessary that it be operated and maintained only by trained personnel.

Persons under the influence of drugs or alcohol or who are subject to seizures, dizziness or loss of physical control must not operate this machine.

#### **Operator Training**

Operator training must cover:

1. Use and limitations of the controls in the platform and at the ground, emergency controls and safety systems.
2. Control labels, instructions, and warnings on the machine.
3. Rules of the employer and government regulations.
4. Use of approved fall protection device.
5. Enough knowledge of the mechanical operation of the machine to recognize a malfunction or potential malfunction.

6. The safest means to operate the machine where overhead obstructions, other moving equipment, obstacles, depressions, holes, and drop-offs exist.
7. Means to avoid the hazards of unprotected electrical conductors.
8. Specific job requirements or machine application.

#### **Training Supervision**

Training must be done under the supervision of a qualified person in an open area free of obstructions until the trainee has developed the ability to safely control and operate the machine.

#### **Operator Responsibility**

The operator must be instructed that he/she has the responsibility and authority to shut down the machine in case of a malfunction or other unsafe condition of either the machine or the job site.

## **2.2 Preparation, Inspection, and Maintenance**

The following table covers the periodic machine inspections and maintenance recommended by JLG Industries, Inc. Consult local regulations for further requirements for aerial work platforms. The frequency of inspections and maintenance must be increased as necessary when the machine is used in a harsh or hostile environment, if the machine is used with increased frequency, or if the machine is used in a severe manner.

### **NOTICE**

**JLG INDUSTRIES, INC. RECOGNIZES A FACTORY-TRAINED SERVICE TECHNICIAN AS A PERSON WHO HAS SUCCESSFULLY COMPLETED THE JLG SERVICE TRAINING SCHOOL FOR THE SPECIFIC JLG PRODUCT MODEL.**

## SECTION 2 - USER RESPONSIBILITIES, MACHINE PREPARATION, AND INSPECTION

**Table 2-1. Inspection and Maintenance Table**

TYPE	FREQUENCY	PRIMARY RESPONSIBILITY	SERVICE QUALIFICATION	REFERENCE
Pre-Start Inspection	Before using each day; or whenever there's an Operator change.	User or Operator	User or Operator	Operator and Safety Manual
Pre-Delivery Inspection <i>(See Note)</i>	Before each sale, lease, or rental delivery.	Owner, Dealer, or User	Qualified JLG Mechanic	Service and Maintenance Manual and applicable JLG inspection form
Frequent Inspection	In service for 3 months or 150 hours, whichever comes first; or Out of service for a period of more than 3 months; or Purchased used.	Owner, Dealer, or User	Qualified JLG Mechanic	Service and Maintenance Manual and applicable JLG inspection form
Annual Machine Inspection	Annually, no later than 13 months from the date of prior inspection.	Owner, Dealer, or User	Factory-Trained Service Technician <i>(Recommended)</i>	Service and Maintenance Manual and applicable JLG inspection form
Preventative Maintenance	At intervals as specified in the Service and Maintenance Manual.	Owner, Dealer, or User	Qualified JLG Mechanic	Service and Maintenance Manual
<b>NOTE:</b> <i>Inspection forms are available from JLG. Use the Service and Maintenance Manual to perform inspections.</i>				

### Pre-Start Inspection

The Pre-Start Inspection should include each of the following:

1. **Cleanliness** – Check all surfaces for leakage (oil, fuel, or battery fluid) or foreign objects. Report any leakage to the proper maintenance personnel.
2. **Decals and Placards** – Check all for cleanliness and legibility check and that none of the decals and placards are missing. Check that all illegible decals and placards are cleaned or replaced.
3. **Operators and Safety Manuals** – Make sure a copy of the Operator and Safety Manual, EMI Safety Manual (Domestic only), and ANSI Manual of Responsibilities (Domestic only) is enclosed in the weather resistant storage container.
4. **Walk-Around Inspection** – Refer to Figure 2-1. on page 2-6.
5. **Battery** – Charge as required.
6. **Fuel** (*Combustion Engine Powered Machines Only*) – Add the proper fuel as necessary.
7. **Hydraulic Oil** – Check the hydraulic oil level. Ensure hydraulic oil is added as required.
8. **Function Check** – Once the “Walk-Around” Inspection is complete, perform a function check of all systems in an area free of overhead and ground level obstructions. Refer to Section 3 for more specific instructions.

### **WARNING**

**IF THE MACHINE DOES NOT OPERATE PROPERLY, TURN OFF THE MACHINE IMMEDIATELY! REPORT THE PROBLEM TO THE PROPER MAINTENANCE PERSONNEL. DO NOT OPERATE THE MACHINE UNTIL IT IS DECLARED SAFE FOR OPERATION.**

## 2.3 FUNCTION CHECK

The function check of all systems should be performed in an area free of overhead and ground level obstructions. Perform a function check as follows:

1. Set-up machine for operation, according to instructions in Section 4, set floor stop, etc.
2. Enter platform, raise and lower platform 2 ft. to 3 ft. (.61m to .92 m) several times. Check for smooth elevation and lowering of platform.
3. (*If Equipped - Machines with side entry-material tray platform and optional platform gate alarm*). Raise the platform approximately 2 in. or more, check the gate alarm will sound when either platform gate is opened.
4. With platform completely lowered, check hydraulic oil level in reservoir at ground control station. Maintain an oil level to the "Fill to Line" indicator on the side of the reservoir. **NEVER USE HYDRAULIC BRAKE FLUID.**



### 2.4 DAILY WALK-AROUND INSPECTION

It is the user/operator's responsibility to inspect the machine before the start of each workday. It is recommended that each user/operator inspect the machine before operation, even if the machine has already been put into service under another user/operator. This Daily Walk-Around Inspection is the preferred method of inspection.

#### General

Begin the "Walk-Around Inspection" at item 1 listed following. Continue around machine checking each item in sequence for the conditions listed in the "Walk-Around Inspection Check list".

#### WARNING

**TO AVOID INJURY DO NOT OPERATE MACHINE UNTIL ALL MALFUNCTIONS HAVE BEEN CORRECTED. USE OF A MALFUNCTIONING MACHINE IS A SAFETY VIOLATION.**

**TO AVOID POSSIBLE INJURY, BE SURE MACHINE POWER IS "OFF" DURING "WALK-AROUND INSPECTION".**

**NOTE:** *Do not overlook visual inspection of chassis underside. Checking this area often results in discovery of conditions which could cause extensive machine damage.*

- 1. Wheels and Casters** - Properly secured, wheels and casters turn freely and are properly lubricated. Check for any visible damage.
- 2. Floor Stop(s)** - Properly secured to frame, no visible damage (*cracks, distortion, etc.*) and is functioning properly.
- 3. Base Frame** - No visible damage; components properly secured, no loose wires dangling below base; bubble level in place and functioning properly.
- 4. Battery/Battery Charger Installation** - (*DC Machines*) Proper battery electrolyte level (*except optional sealed AGM battery*), cables secure, no damage or corrosion.
- 5. Motor/Pump/Reservoir Unit** - All properly secured, no visible damage, no evidence of hydraulic leaks. Check that hydraulic reservoir fluid level is filled to the "Fill to Line" mark on the side of the reservoir.
- 6. Manual Descent Valve** - (Located under the base frame at the rear of the machine), properly secured, no loose or missing parts, no visible damage.
- 7. Ground Controls** - Key switch operable, no visible damage; placards secure and legible; emergency stop switch, no visible damage and properly set for operation.

## SECTION 2 - USER RESPONSIBILITIES, MACHINE PREPARATION, AND INSPECTION

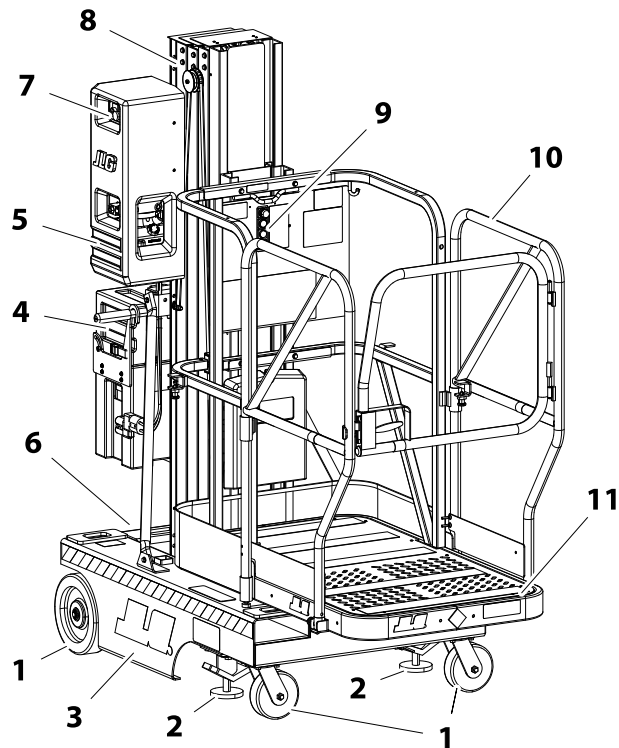

Daily Walk-Around Inspection Items	
1.	Wheels & Casters
2.	Floor Stop(s)
3.	Base Frame
4.	Battery Box/Charger
5.	Motor/Pump/Reservoir Unit
6.	Manual Descent Valve
7.	Ground Controls
8.	Mast Installation
9.	Platform Controls
10.	Guard Rail Installation
11.	Platform Assembly

Figure 2-1. Daily Walk-Around Inspection.

## SECTION 2 - USER RESPONSIBILITIES, MACHINE PREPARATION, AND INSPECTION

---

8. **Mast Installation** - Mast sections properly secured, no visible damage to mast sections, no loose or missing parts, slide pads properly secured. Mast chains and cables properly secured, lubricated and undamaged. Sequencing cables properly secured and undamaged. Sheaves and pins are properly secured, have no visible damage, no loose or missing parts and are lubricated.
9. **Platform Controls** - Up/Down and Function Enable buttons properly secured, no loose or missing parts, no visible damage. Placards secure and legible, emergency shut-off button set for operation. Control markings legible; Operators manual enclosed in manual storage tube.
10. **Guard Rail Installation** - All railings securely attached, no visible damage, no missing parts; sliding entry bar in proper working order. Platform gate working properly, no visible sign of damage.
11. **Platform Assembly** - Secure to mast; no loose or missing parts, no visible damage. Control and power cables, no visible damage; cables properly tensioned and seated in control cable sheaves; control cable sheaves not damaged and rotate freely.  
If equipped with side-entry platform with material tray (OPTION), check material tray is secure to the platform railing, no loose or missing parts, and tray locks securely in place when raised into position.

In addition to the Daily Walk-Around Inspection, be sure to include the following as part of the daily inspection:

### **Batteries Charged**

Start each day with fully charged batteries. (See “*BATTERY CHARGING*” on page 4-2.)

### **Overall Cleanliness**

Keep oil, grease, water, etc. wiped from standing surfaces and hand holds.

### **Placards**

Keep all information and operating placards clean and unobstructed. Cover areas where placards are present when using the machine for spraying paint or any material which could cover these surfaces and reduce legibility.

### **Lubrication**

For those parts pointed out in the Walk-Around Inspection requiring lubrication, (See “*Lubrication Points (See Table 7-2. on page 7-9)*” on page 7-8.) for specific time interval requirements.



## SECTION 3. MACHINE CONTROLS AND INDICATORS

### 3.1 OPERATING CHARACTERISTICS AND LIMITATIONS

#### General

A thorough knowledge of the operating characteristics and limitations of the machine is always the first requirement for any user, regardless of user's experience with similar types of equipment.

#### Placards

*(See Figure 3-4.)*

Important points to remember during operation are provided at the control stations by DANGER, WARNING, CAUTION, IMPORTANT, NOTICE and INSTRUCTION placards. This information is placed at various locations on the machine for the express purpose of alerting personnel of potential hazards constituted by the operating characteristics and load limitations of the machine. See Foreword at the start of this manual for a definition of the seriousness of each of the above placard types. See Decal Location Figure 3-4. on page 3-5 in this section for decals which apply to this machine.

#### Capacities

Raising the platform above the stowed position is based on the following criteria:

- The machine is positioned on a smooth, firm level surface.
- The load is within manufacturer's rated capacity.
- All machine systems are functioning properly.
- The machine floor brake on the base frame is properly set and locked in place.

#### Stability

This machine, as originally manufactured by JLG and operated within its rated capacity on a smooth, firm and level supporting surface, provides a stable aerial platform for all platform positions.

### 3.2 CONTROLS AND INDICATORS

#### Ground Control Station (See Figure 3-1.)

**NOTE:** When the machine is shut down for overnight parking or battery charging, be sure the POWER ON/OFF KEY SWITCH is positioned to OFF to prevent draining the batteries.

##### 1. POWER ON/OFF Key Switch

A key operated power on/off switch located on the ground control station panel controls power to all functions on the unit. The machine will not operate without the key inserted and turned to the ON position. When left unattended removing key will prevent unauthorized machine use.

##### 2. EMERGENCY STOP Button

An emergency stop (*RED button*) is mounted on both the ground control station and the platform control panel. When the button is depressed, all machine functions will stop. To re-activate power to the machine, turn emergency stop button clockwise until button is reset.

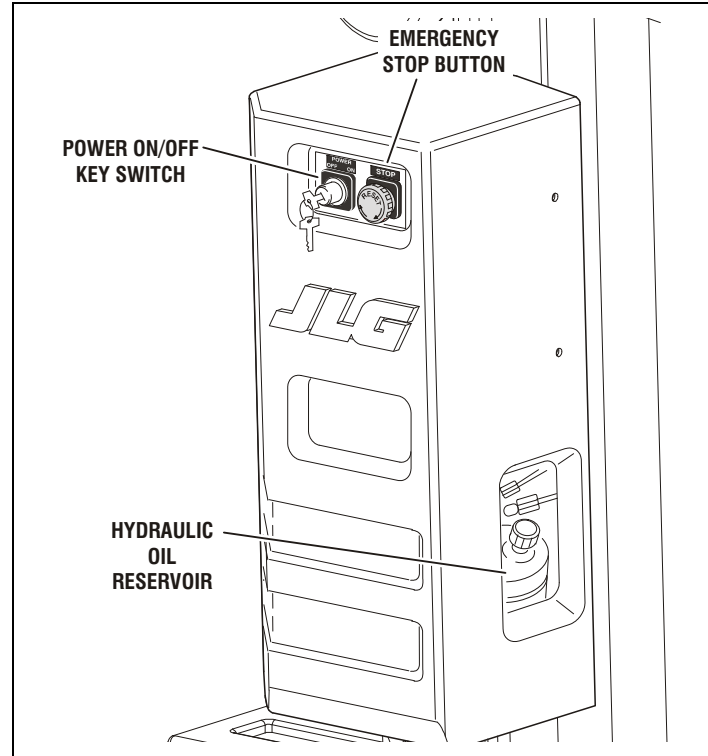

Figure 3-1. Ground Control Station.

## SECTION 3 - MACHINE CONTROLS AND INDICATORS

### 3. HYDRAULIC RESERVOIR/CIRCUIT BREAKER/FUSE

*(located inside ground control station housing)*

The hydraulic reservoir is housed inside the ground control station, the hydraulic oil level can be checked through an access hole in the side of the cover. Maintain an oil level to the "Fill to Line" indicator on the side of the reservoir.

**NOTE:** Check hydraulic oil only when platform is completely lowered and after cycling platform up/down a few times.

A 5 Amp fuse is located inside the ground control station.

### 4. MANUAL DESCENT VALVE Knob

This (RED) knob, located under the base frame at the rear of the machine, (See Figure 3-2.), provides for lowering of the platform in the event of an emergency or power failure. To operate PULL knob to LOWER platform, RELEASE knob to STOP lowering.

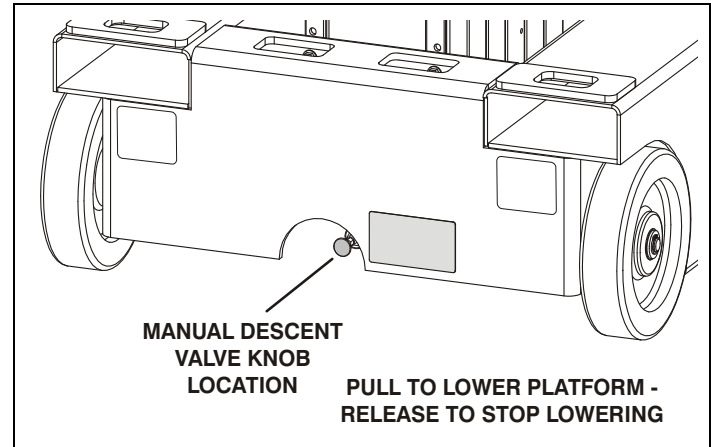

**Figure 3-2. Manual Descent Valve Location.**

## SECTION 3 - MACHINE CONTROLS AND INDICATORS

### Platform Control Station

(See Figure 3-3.)

#### 1. EMERGENCY STOP/SHUT-OFF Button.

An EMERGENCY STOP (RED) button is provided in order to turn machine power on and off in the platform and also to turn off machine power in the event of an emergency. Power is on when the switch is in the reset position (turned completely clockwise - out). Power is off and all machine functions will stop, when button is depressed.

#### 2. FUNCTION ENABLE Button.

This (GREEN) button must be depressed simultaneously with either the UP or DOWN platform function buttons in order to operate the platform.

#### 3. PLATFORM UP Button.

When depressed simultaneously with ENABLE button raises the platform to a higher level.

#### 4. PLATFORM DOWN Button.

When depressed simultaneously with ENABLE button lowers the platform to a lower level.

#### 5. AUXILIARY LOWERING DEVICE Button (OPTION)

This button located on the mast behind the platform control station, will in the event of a loss of power from the machines main power source, lower the platform from a raised position.

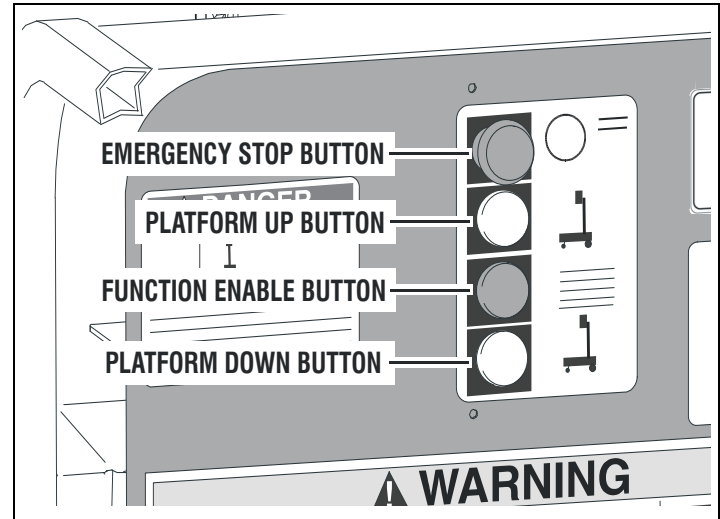

Figure 3-3. Platform Control Station.



Decal Installation

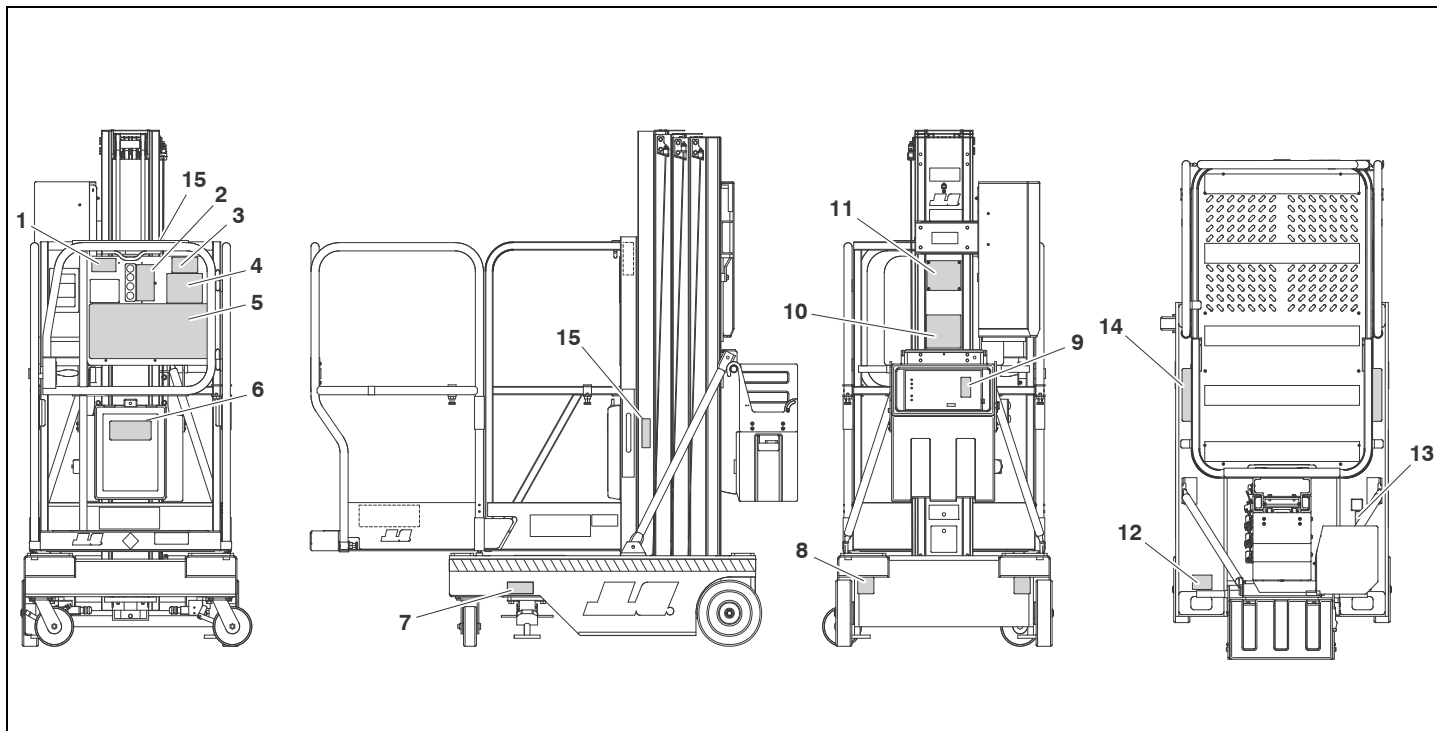

Figure 3-4. SP Machine - Decal Installation. (See Table 3-1.)

## SECTION 3 - MACHINE CONTROLS AND INDICATORS

---

**Table 3-1. SP Series Decal Installation Chart.**

Location	ANSI	ANSI (LAT)	ANSI (JPN)	ANSI (CHI)	CSA (FRE)
1	1704366	1704594	1704777	1704970	1704366
2	1704212	1704213	1704215	1704076	1704212
3	1706343	1706343	1704775	1704969	1706341
4	1703781	1704029	1704086	1704077	1703781
5	1704221	1704222	1704224	1704964	1704221
6	1701509	1701509	1701509	1701509	1701509
7	1704424	1704593	1704776	1704968	1704424
8	1703817	1704029	1703817	1703817	1703817
9	1703785	1704031	1704031	1704079	1703785
10	1703784	1704030	1704030	1704078	1703784
11	1706953	1706953	1706953	1706953	1706953
12	1703814	1703814	1703814	1703814	1703814
13	1703789	1704034	1704092	1704083	1703789
14	1703786	1704032	1704032	1704081	1703786
15	1704277	1704277	1704277	1704277	1704277

## **SECTION 4. MACHINE OPERATION**

### **4.1 MACHINE DESCRIPTION**

SP machines are manually propelled machines, with a platform mounted to an elevating aluminum mast mechanism. The mast is raised and lowered by a hydraulic cylinder extending between mast section-1 and -2, the remaining mast sections are proportionally extended and retracted using steel chains and cables. Hydraulic pressure is supplied to the lift cylinder by an electrically powered hydraulic pump. The platform may be raised only when lift is positioned on smooth, firm, level surface with the floor stop set. The SP personnel lift's intended purpose is to provide personnel access to areas above ground level.

The SP personnel lift has a primary operator control station in the platform. From this control station the operator can raise and lower the platform. A ground control station is also provided. This station contains a keyed power on/off switch, an emergency stop button and an emergency/manual decent valve which enables the platform to be lowered to the ground in an emergency, if the operator in the platform is unable to do so, or if a power failure should occur.

Instructions and warnings are posted adjacent to both operator control stations and at other places on the machine. It is extremely important that the user/operator know what instructions and warnings are placed on the machine and in the manual. And that these

instructions and warning's be reviewed periodically. The JLG personnel lift is designed to provide efficient and safe operation when maintained and operated in accordance with instructions and warnings on the machine, in the Operating, Safety and Maintenance Manual and all job-site and government rules and regulations.

As with any type of machinery, the operator is very important to efficient and safe operation. It is absolutely necessary that the JLG lift be regularly maintained in accordance with this manual.

Any evidence of lack of maintenance, malfunction, excessive wear, damage or modification to the machine must be reported immediately to the machine owner, the job-site supervisor or safety manager and the machine must be taken out of service until all discrepancies are corrected.

The JLG SP personnel lift is not intended to be used to lift material other than hand-picked stock or supplies. Supplies or tools which extend outside the platform are prohibited except for JLG approved receptacles. The personnel lift must not be used as a forklift, crane, or support for overhead structure.

The total platform capacity is to be uniformly distributed in the center of the platform. This means that the total combined weight of personnel, tools and supplies loaded into the platform must not exceed the total platform capacity.

### 4.2 GENERAL

This section provides the necessary information needed to operate the machine. Included in this section are the procedures for set-up, raising, lowering, platform loading and transporting. It is important that the user read and understand the proper procedures before operating the machine. Although some of the more important operating safety precautions will be listed in the following paragraph sections, it is extremely important all safety precautions in Section 1 - Safety Precautions be read and understood before operating machine. If a "Daily Walk-Around Inspection", (see Section 2) has not been completed, perform this inspection before starting set-up and operation. The operator must also be familiar with all machine controls as described in Section 3 - "User/Operator Responsibilities and Machine Controls".

### 4.3 BATTERY CHARGING

These machines are equipped standard with 12 volt, 10 amp output battery chargers (120V-AC/60Hz or 100-240V-AC/50/60Hz input). The battery charger has a microprocessor controlled automatic charge sensing circuit which can determine cell voltage and regulates charger output as required. The charger automatically terminates charging when a full battery charge is achieved.

**NOTE:** *Wet cell battery maintenance information can be found in Section 7 of this Operation Manual.*

**NOTE:** *If machine is equipped with the AGM (Absorption Gas Mat) battery option, this battery is a VRLA (valve regulated lead acid) type and is a sealed maintenance free battery. The charger supplied with this battery is of higher output (20 amp), resulting in a quicker charge cycle. This charger operates similarly to the standard charger as outlined in the following, except there is only a charge complete (100%) LED.*

#### Battery Charger Operation

1. Position machine in well ventilated area near an AC electrical outlet and set the Ground Control-PLAT/OFF/GRND key switch to the OFF position.

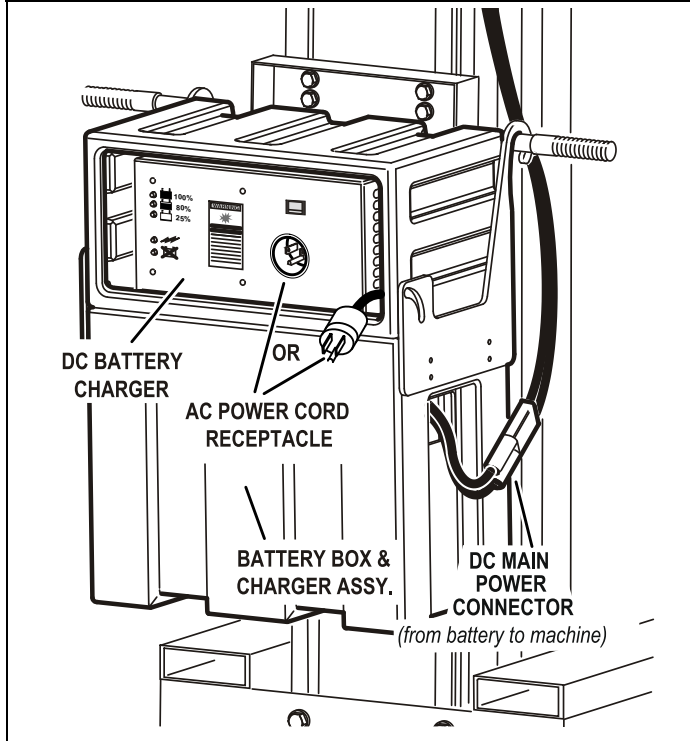

**Figure 4-1. Battery Box and Charger Assembly - (Original Design)**

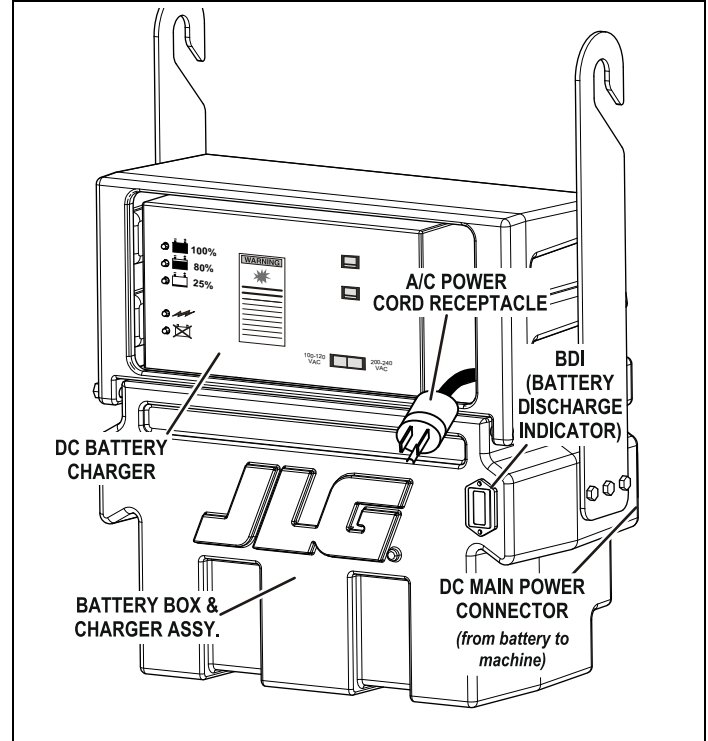

**Figure 4-2. Battery Box and Charger Assembly - (Compact Design)**

## SECTION 4 - MACHINE OPERATION

---

2. Connect the battery charger AC power cord receptacle to a properly grounded AC electrical outlet, use a suitable extension cord.
3. When plugged in, the charger runs through a self-diagnostic check. The LED's on the front panel of the battery charger flash in the sequence.
4. When ready to charge, the CHARGER ON LED and the INCOMPLETE CHARGE (25%) LED on the front panel of the charger will light up, the charger will then begin to charge the batteries.

**NOTE:** *If the ABNORMAL CYCLE LED comes on and stays on at any time during the charge cycle, see sub-section following about the ABNORMAL CYCLE indicator LED.*

5. When the battery cell voltage reaches 2.37 V/cell the 80% CHARGE LED on the front panel of the charger will light up. The charger then continues to monitor the increase in charge until it sees no increase, and then terminates the charging process.
6. The CHARGE COMPLETE (100%) LED will come on when the charging process is finished.
7. Remove the power cord from the AC power cord receptacle on the face of the charger.

### Abnormal Cycle Indicator LED

If the ABNORMAL CYCLE indicator LED should come on during the normal charging cycle of the batteries, it could indicate any of the following conditions;

- The AC input to the charger was interrupted, i.e. local power failure or charger cable was unplugged or bumped and power was interrupted intermittently.
- A dead cell or cells in the battery would prevent the charger from sensing enough voltage to complete the battery charge.
- One or more of the battery terminal connections loose or corroded resulting in an intermittent incomplete circuit.

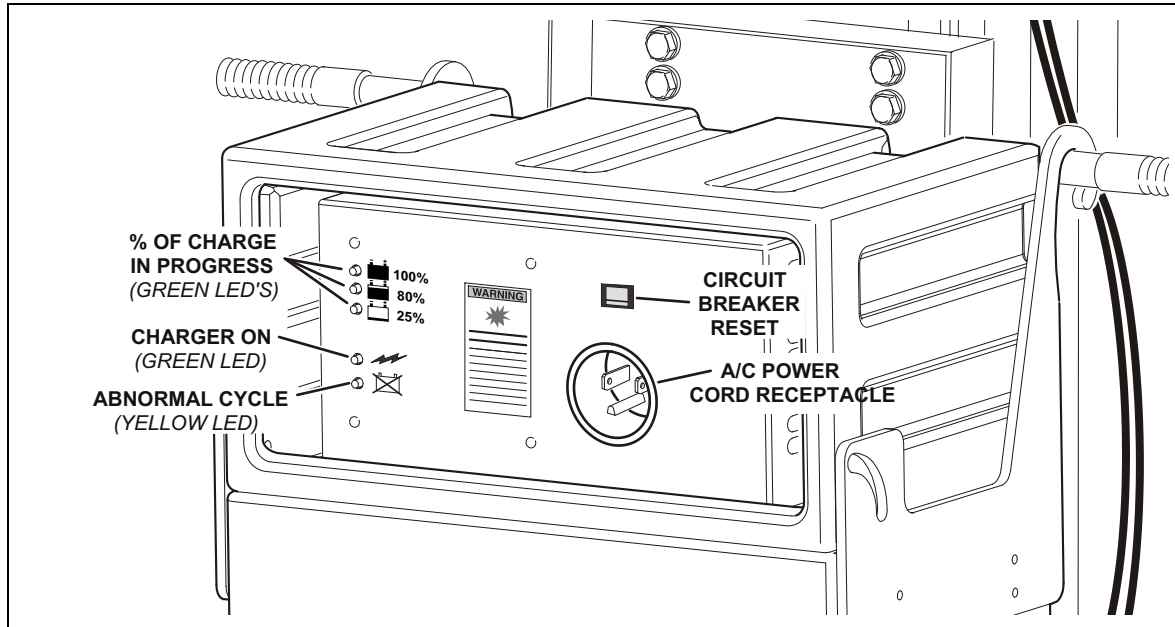

**Figure 4-3. Battery Charger - Front Panel - 120V-AC Input.**

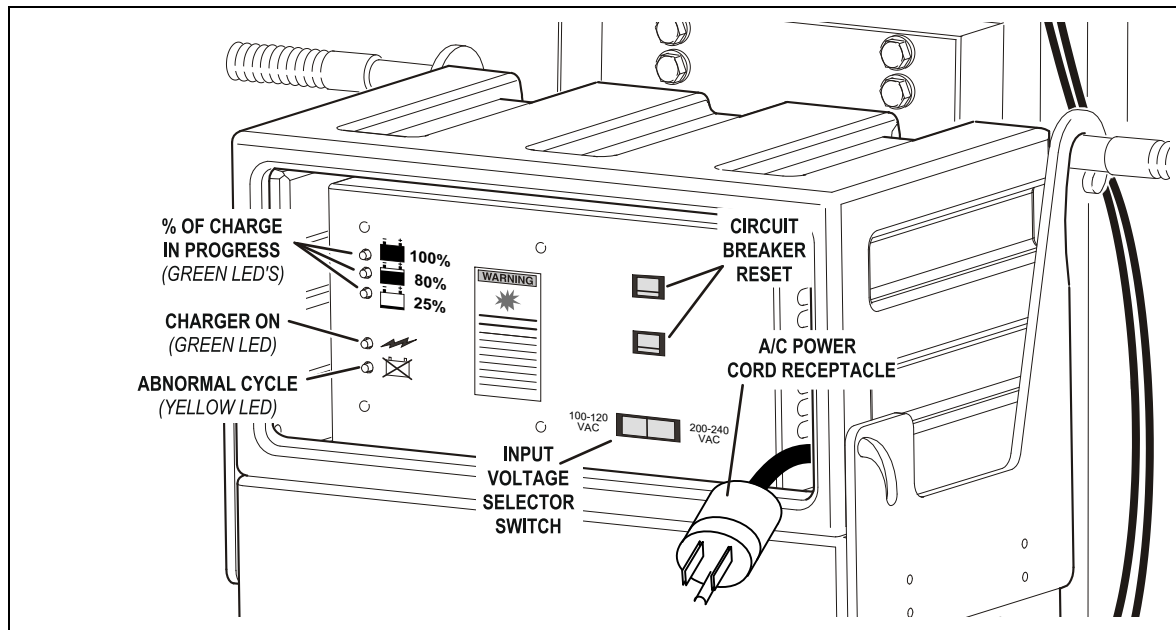

**Figure 4-4. Battery Charger - Front Panel - 120 - 240V-AC Input.**



## **4.4 MACHINE SET-UP AND OPERATION**

The following sequence of set-up procedures must be followed to safely operate this machine.

1. Position machine in work area. Work area must be a smooth, firm, level surface.

**NOTE:** *Check that battery box assembly is installed, battery is charged and connected to the machine's DC receptacle.*

2. Set Power On/Off Key switch to the ON position at the ground control station.
3. Check both Emergency Stop switches, one on platform control station and one on ground control station, they must be in the reset position for operation.
4. Set Floor Stop, see steps following.

### **Floor Stop Operation**

*(See Figure 4-5.)*

1. Located on both sides of the machine under the base frame, behind either of the front caster wheels, are the floor stop assemblies. Engage and lock one or both of the floor stop assemblies down into position

### **⚠ WARNING**

**THE FRONT CASTER WHEELS SHOULD BE RELIEVED OF THE MACHINES WEIGHT ENOUGH SO THE MACHINE DOES NOT ROLL IN ANY DIRECTION. IF THIS IS NOT THE CASE DO NOT ATTEMPT TO ELEVATE THE PLATFORM UNTIL THE FLOOR STOP IS OPERATING PROPERLY.**

2. To disengage the floor stop, apply pressure to the release rod or lift up on the floor stop pedal.

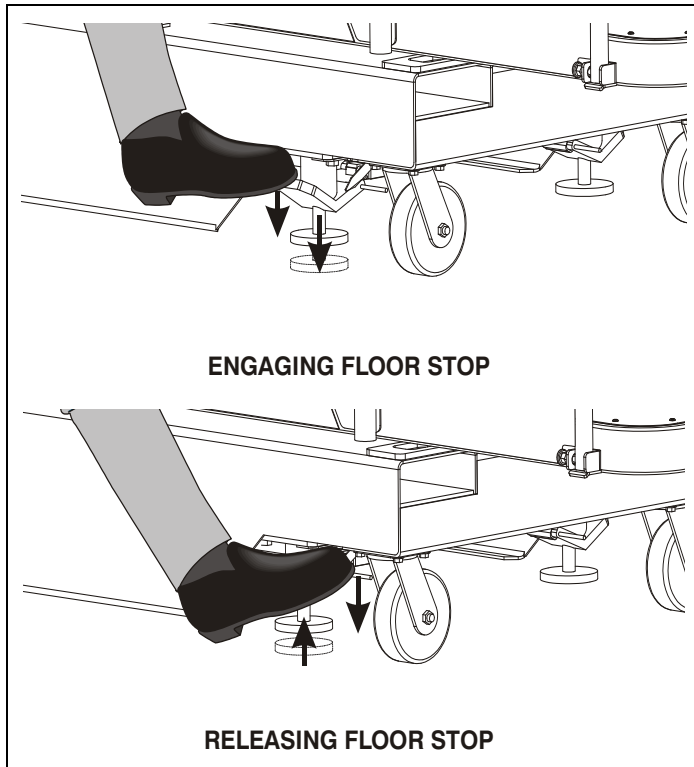

Figure 4-5. Engaging & Releasing Floor Stop.

### Raising and Lowering the Platform

1. Enter platform and close the entry gate, see Section 4.5, PLATFORM CONFIGURATIONS.
2. Attach your fall protection harness to the applicable lanyard attachment on the machine.

**NOTE:** On the platform control panel the **FUNCTION ENABLE** (green button) must be depressed simultaneously with either the **UP** or **DOWN** button in order for these functions to work.

### **⚠ WARNING**

**DO NOT ATTEMPT TO RAISE THE PLATFORM UNLESS EITHER OF THE FLOOR STOP ASSEMBLIES IS PROPERLY SET AND MACHINE IS ON A SMOOTH, FIRM, LEVEL SURFACE.**

**BEFORE AND WHILE RAISING THE PLATFORM, CHECK CLEARANCES ABOVE AND AROUND PLATFORM AND MAST TO ENSURE ADEQUATE CLEARANCE OF SURROUNDING OBJECTS AND PERSONNEL.**

**NOTE:** Machines equipped with the platform gate alarm (option), when the platform is raised approximately 2 in. or more, the platform gate alarm will sound if either of the platform gates are opened.

3. To **RAISE** platform up, depress the **FUNCTION ENABLE BUTTON** (green) and **PLATFORM UP BUTTON** (top,

white button) on the platform control panel simultaneously. Upon reaching desired elevation level release UP and FUNCTION ENABLE buttons.

### WARNING

**ENSURE AREA BENEATH PLATFORM IS FREE OF PERSONNEL AND OBSTRUCTIONS PRIOR TO LOWERING PLATFORM.**

- To LOWER platform, depress FUNCTION ENABLE BUTTON (green) and PLATFORM DOWN BUTTON (bottom, white button) on control panel simultaneously. Upon reaching desired elevation level release DOWN and FUNCTION ENABLE buttons.

**Auxiliary Lowering Switch (Option):** To lower the platform using the auxiliary lowering switch, be certain the emergency stop switch on the platform control panel is set to the reset (on) position. Press and hold both the (green) function enable button on the control panel and the auxiliary lowering switch, on the side of the mast behind the control panel, until platform is lowered.

**NOTE:** Machines equipped with platform gate alarm (option), the platform must be completely lowered when exiting the platform or the platform gate alarm will sound.

## 4.5 PLATFORM CONFIGURATIONS

### Platform Loading

The platform maximum rated load capacity is shown on a placard located on the platform control panel and is based upon the following criteria.

Maximum capacity for the SP model is as follows:

**Table 4-1. Maximum Platform Capacity.**

PLATFORM TYPE	PLATFORM CAPACITY	
	ANSI USA/Latin America	CSA (Canada)
12/15SP		
StockPicker (28 in. X 48 in.)	500 lb. (227 kg) * 250 lb. (113kg) Front - * 250 lb. (113kg) Rear	400 lb. (182 kg) * 200 lb. (91kg) Front - * 200 lb. (91kg) Rear
Extendible 26 in. X 49 in.	500 lb. (227 kg) * 250 lb. (113kg) Front - * 250 lb. (113kg) Rear *	400 lb. (182 kg) * 200 lb. (91kg) Front - * 200 lb. (91kg) Rear
Side Entry with Tray 23 in. X 27 in.	500 lb. (227 kg) 250 lb. (113kg) Tray - 250 lb. (113kg) Platform	400 lb. (182 kg) 200 lb. (91kg) Tray - 200 lb. (91kg) Platform

\* Distribute weight evenly over the platform base.

## SECTION 4 - MACHINE OPERATION

### StockPicking Platform Operation

(See Figure 4-6. and Figure 4-7.)

The stockpicking platform is available in two (2) versions.

- Fixed side-rail version
- Folding side-rail version

#### **⚠ CAUTION**

THE STOCKPICKER PLATFORM ALLOWS THE MACHINE TO BE OPERATED IN AN OPEN RAIL CONFIGURATION (SEE ILLUSTRATION).

THE OPERATOR MUST WEAR A FULL BODY HARNESS WITH A LANYARD (MAX. 6 FT. (1M) ATTACHED TO THE AUTHORIZED LANYARD POINT OR A BODY BELT EQUIPPED WITH A LANYARD SHORT ENOUGH TO PREVENT A FALL FROM THE PLATFORM.

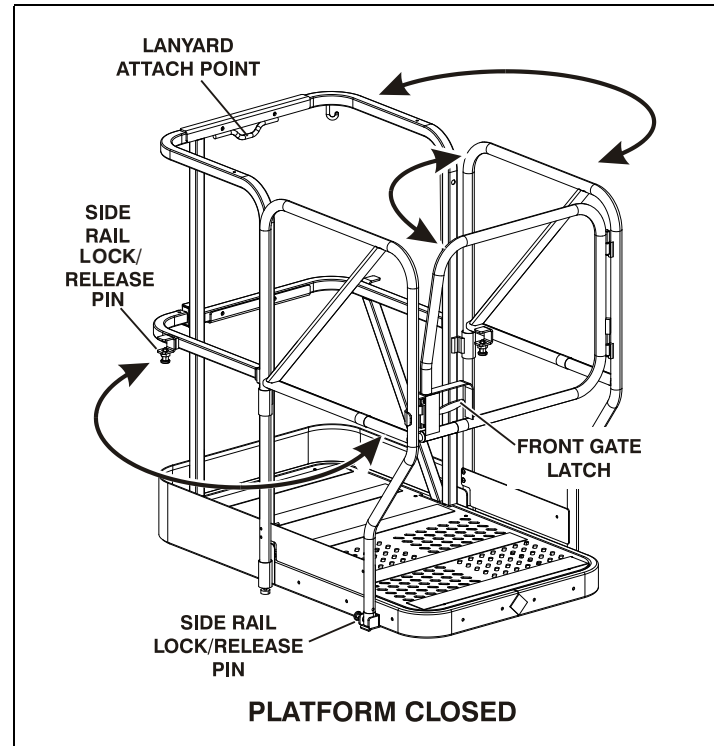
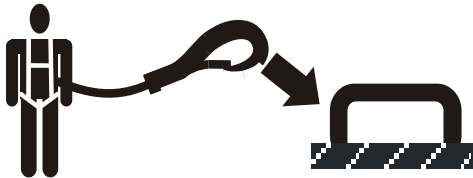
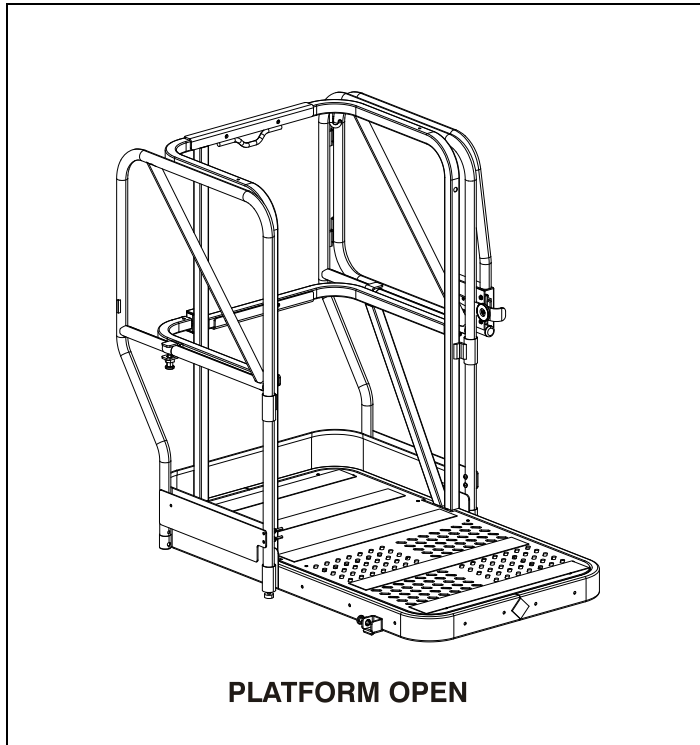
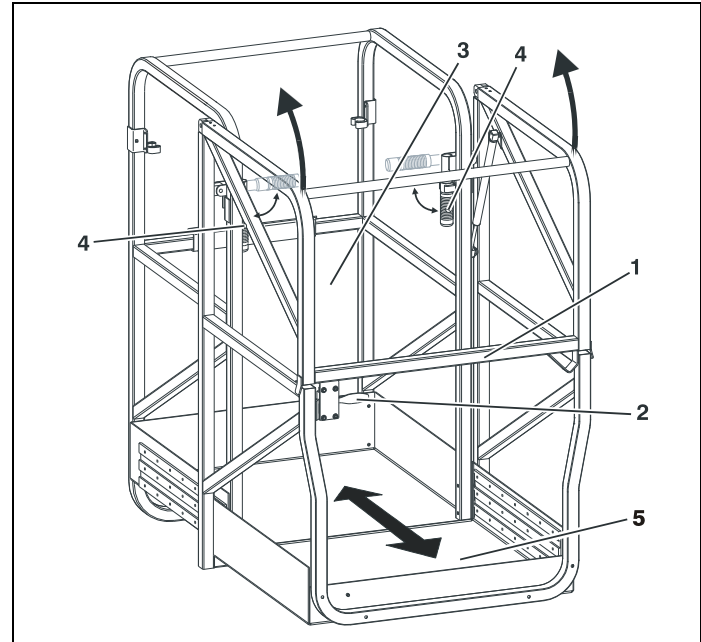

Figure 4-6. Platform Operating Configurations.



**Figure 4-7. Platform Operating Configurations.**

**Extendible Platform Operation - OPTION**



**EXTENDIBLE PLATFORM - OPTION (GULL-WING ENTRY)**

- |  |                                |
|--|--------------------------------|
| 1. Gullwing Entry Gate                           | 4. Extension Slide/Lock Handle |
| 2. Entry Gate Latch                              | 5. Sliding Extendible Section  |
| 3. Lanyard Attach Point <i>(on side of mast)</i> |                                |

## SECTION 4 - MACHINE OPERATION

### Extendible Platform - Lanyard Attachment

**⚠ CAUTION**

JLG INDUSTRIES, INC. RECOMMENDS THE OPERATOR IN THE PLATFORM WEAR A FULL BODY HARNESS WITH A LANYARD ATTACHED TO AN AUTHORIZED LANYARD ANCHORAGE POINT.

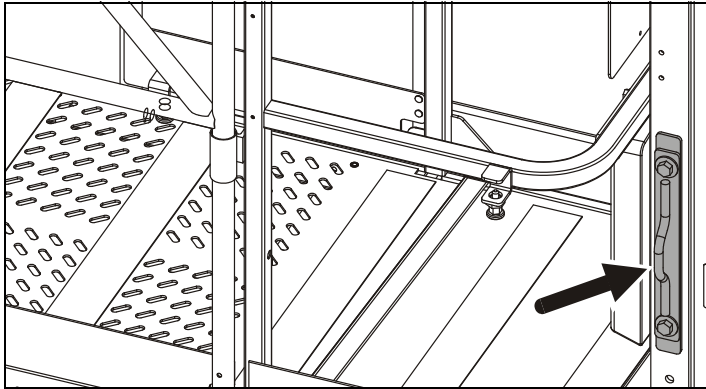
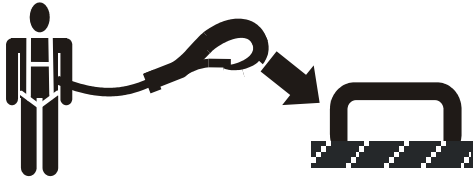

The main lanyard attach point for 12/15SP machines equipped with the extendible platform option is located on the lower left side of the mast platform header, just behind the operators platform.

**⚠ CAUTION**

**AFTER ENTERING THE PLATFORM, BEFORE BEGINNING OPERATION ALWAYS CLOSE THE PLATFORM ENTRY GATE(S).**

**Side Entry Platform with Material Tray - OPTION**

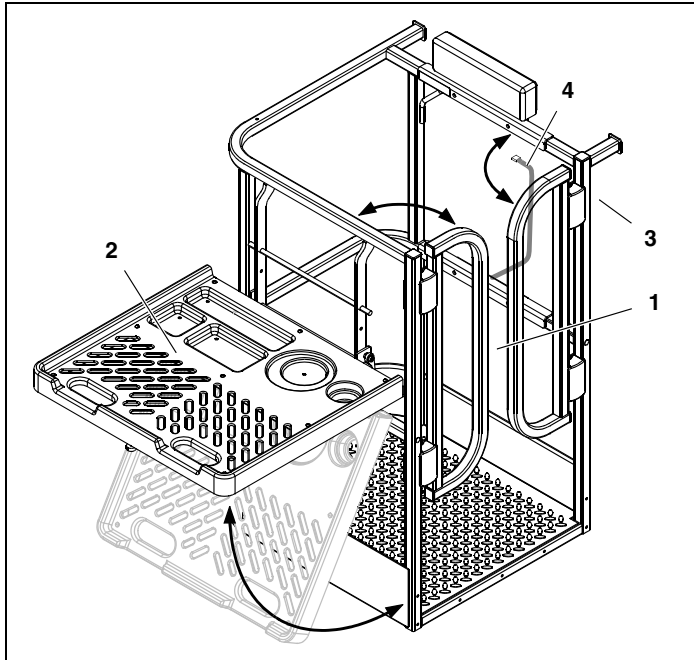

**SIDE ENTRY PLATFORM w/FOLDING MATERIAL TRAY**

- 1. Swing Side Entry Gates
- 2. Folding Material Tray
- 3. Lanyard Attach Point - (on mast)
- 4. Gate Alarm Harness (OPTION)

**Platform Gate Alarm - OPTION**

To determine if your machine is equipped with the platform gate alarm, look for a wire harness exiting the lower platform rail, near the center at the rear of the platform. The gate alarm harness plugs into the control station box behind the decal board. See item 4 of illustration - SIDE ENTRY PLATFORM w/MATERIAL TRAY.

## SECTION 4 - MACHINE OPERATION

### 4.6 QUICK-CHANGE PLATFORM MOUNTING

Quick-Change platform mounts which allow quick removal and installation of currently available quick-change platforms.

**NOTE:** 12/15SP Models require the installation of the Quick-Change mount kit to use Quick-Change Platforms.

#### Platform Removal

5. Remove the platform control console from the platform and lay aside.
6. Remove both upper and lower mount attach pins securing the platform support rails to the mast mounting channels.
7. Swing and lift the platform out of the mounts and lay aside.

#### Platform Installation

1. Set platform in upper and lower mounts.
2. Install attach pins in upper and lower mounts.
3. Attach platform control console to platform rail.

#### **⚠ WARNING**

**ENSURE ALL PINS AND FASTENERS ARE INSTALLED AND SECURE PRIOR TO OPERATION.**

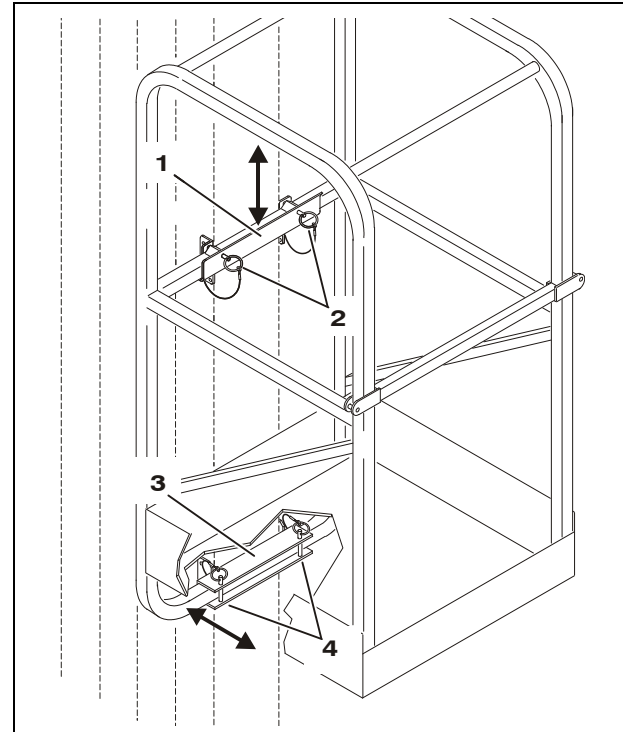

- |                            |                         |
|----------------------------|-------------------------|
| 1. Upper Platform Mount    | 3. Lower Platform Mount |
| 2. Upper Mount Attach Pins | 4. Lower Mount Pins     |



## 4.7 STOWING MACHINE

1. Ensure that platform is fully lowered, turn POWER ON/OFF key switch (*on the Ground Control Station*) to the OFF position.

### NOTICE

WHEN MOVING MACHINE PLEASE FOLLOW ALL SAFETY PRECAUTIONS DESCRIBED IN SECTION 1, "TRANSPORT SAFETY" OF THIS MANUAL. ALSO SEE SECTION 4, "TRANSPORTING AND LIFTING" FOR PROPER PROCEDURES FOR TRANSPORTING.

2. Move machine to a well-protected and well-ventilated area. If necessary, cover the machine so it will be protected if in a hostile environment.
3. Set the floor stop when parking machine for an extended period of time.
4. If necessary remove key from Ground Control Panel POWER ON/OFF key switch to disable machine from unauthorized use.

**NOTE:** *If required, machine batteries should be charged in preparation for next work day.*

## 4.8 TRANSPORTING, LIFTING AND TIE DOWN

### General

The machine may be transported from work-site to work-site using any of the following methods:

- Pushing the machine around on its base wheels.
- Transport with a forklift truck using the forklift pockets in the base-frame or to lift onto a transport vehicle.

### Transporting by Pushing

### NOTICE

CAREFULLY REVIEW ALL SAFETY PRECAUTIONS NOTED IN SECTION 1, "TRANSPORT SAFETY", BEFORE ATTEMPTING TO MOVE MACHINE.

The machine's base frame is equipped with load bearing wheels mounted on a straight axle at the mast end of the machine; and a pair of heavy duty swivel caster wheels mounted on the frame at the platform end of the machine. It is important to closely follow the instructions mentioned in the following WARNING note to ensure safe transport of unit when pushing.

### **⚠ WARNING**

**FAILURE TO HEED THE FOLLOWING INSTRUCTIONS COULD CAUSE THE UNIT TO TIP OVER OR BE HARD TO CONTROL WHEN BEING MOVED WHICH COULD RESULT IN SERIOUS INJURY OR DEATH DUE TO BEING PINNED OR CRUSHED BY UNIT.**

- Walk behind the unit to push and steer using the handles on the mast crossbar.
- On a level surface, always travel with the platform end leading the way.
- On a slope, always travel with the platform end on the low side of the slope.
- Two people are required on slopes up to 5 degrees, a forklift must be used when moving units on slopes greater than 5 degrees.
- Never position the unit sideways on a slope.
- Do not move unit on soft or uneven surfaces, or over obstructions, bumps, debris, etc.

### **NOTICE**

**BEFORE MOVING A MACHINE BY PUSHING, SECURE ANY TOOLS OR OBJECTS WHICH MAY OTHERWISE FALL OFF AND CAUSE INJURY OR BE DAMAGED DURING TRANSPORT.**

### **Lifting**

If it becomes necessary to lift the machine, use suitable lifting equipment capable of handling the weight of the machine

**NOTE:** *Fork lifts, cranes, chains, slings, etc. must be capable of handling the weight of the machine - See Section 7, GENERAL SPECIFICATIONS AND OPERATOR MAINTENANCE for machine gross weight specifications.*

**NOTE:** *All SP models are equipped with forklift pockets at the mast end of frame for transporting the unit. An optional crane hook is available. Do not attempt to lift the machine with a crane, without the optional crane hook.*

### **Transport Vehicle Tie Down**

*(See Figure 4-8.)*

When placing the machine onto a transport vehicle for transport to another work-site, always tie the machine securely to the transport vehicle using the tie down pockets provided on the machine. There are four tie down pockets, one on each corner of the machine. Use corner tie down pockets as needed. Tie down method shown is for illustrative purposes only.

## 4.9 RUG CARRIER ACCESSORY (OPTION)

**NOTE:** *The Rug Carrier Accessory is intended for use in hanging and removal of rugs in hanging display racks only. Use for any other purpose is not authorized by JLG.*

### General

The Rug Carrier Accessory consists of two pivoting arms mounted to the platform left side rails. The pivoting arms are locked in the plane of the platform side rail when not in use (*the stowed position*). The arms are locked into position at approximately 90 degrees to the left side platform side rails when in use (*the carry position*). The pivoting arms' position can be changed by lifting each arm to release the lock, rotating the arm, and lowering each arm back into a locked position.

### Pre-Start Inspection

Prior to use of the Rug Carrier accessory, check the following;

- Carrier arm mounting is secure to the platform railing, no missing or damaged fasteners.
- The arm lock pins are in place and working properly.

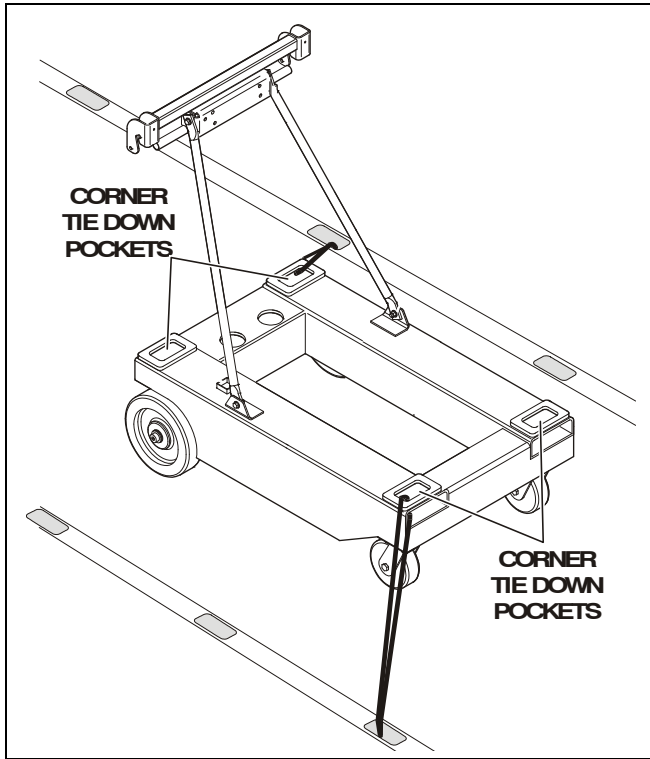

Figure 4-8. SP Tie Down Pockets.

## SECTION 4 - MACHINE OPERATION

### Hanging a Rug using the Rug Carrier Accessory Arms

The following is a description for use of the Rug Carrier accessory in hanging rugs on horizontal pivoting arm display racks.

1. Select the intended location in the display for mounting the rug. Open the display rack to provide adequate space for the lift and rug.
2. With the Rug Carrier Accessory arms stowed, drive the lift into position prior to loading the rug.
3. Swing and lock Rug Carrier Accessory arms into the carry position.
4. Load the rolled rug with the finished side facing the platform. As required, use an assistant to load the rug onto the Rug Carrier Accessory arms.
5. Make sure that the rug is centered over its length on the Rug Carrier Accessory.
6. Elevate the platform to the required height for mounting the rug onto the display arm.
7. Properly attach the rug to the display arm. Never climb onto the platform rails for any reason.
8. After adequately attaching the rug to the display arm, lower the platform, stow the Rug Carrier Accessory arms.

9. As required reposition and elevate the lift to completely attach the rug.

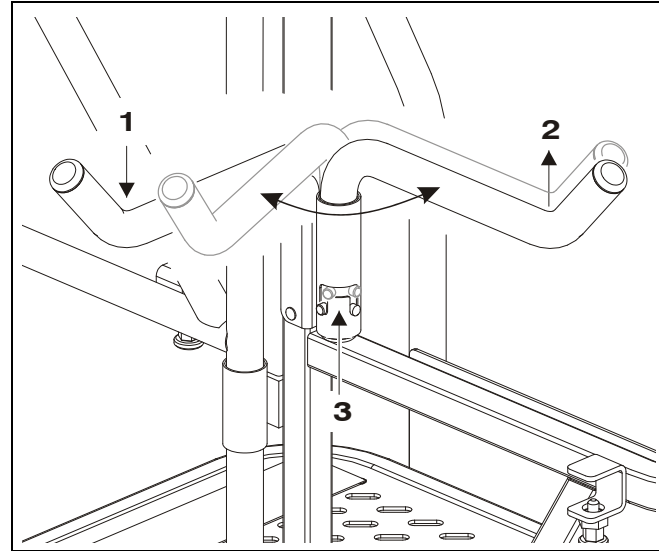

**Positioning Rug Carrier Arms**

1. Carry Position
2. Stowed Position and Lock into Position
3. Lift Arm Up, Swing

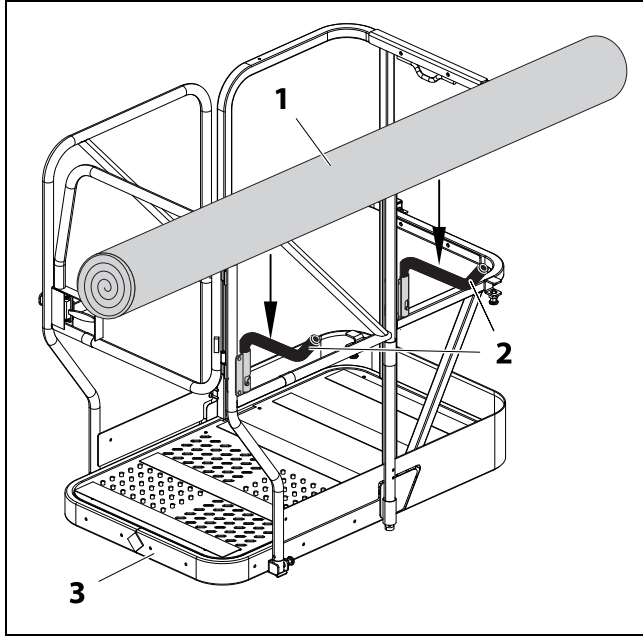

### Positioning Carpet Roll On Rug Carrier

1. Center Carpet on Arms
2. Rest on Arms Here (a)
3. Platform Front

Note: (a) Maximum Capacity of Arms - 150 lb. (68kg)

### Removing a Rug using Rug Carrier Accessory Arms

This section describes the use of the Rug Carrier accessory in removing a rug from a horizontal pivoting arm display rack.

1. Select the intended location in the display for removal of the rug. Open the display rack to provide adequate space for the lift and rug.
2. With the Rug Carrier Accessory arms stowed, drive the lift into position prior to loading the rug.
3. Swing and lock the Rug Carrier Accessory arms into the carry position.
4. Elevate the platform a few feet. Start to roll the rug onto the Rug Carrier Accessory arms.
5. Be certain the rug is centered over its length on the Rug Carrier Accessory.
6. While elevating to the required height for removing the rug from the display arm, continue to roll the rug until it is completely rolled up on the carrier arms.
7. Properly remove the rug from the display arm. Never climb onto the platform rails for any reason.
8. After adequately removing the rug from the display arm, lower the platform.

## SECTION 4 - MACHINE OPERATION

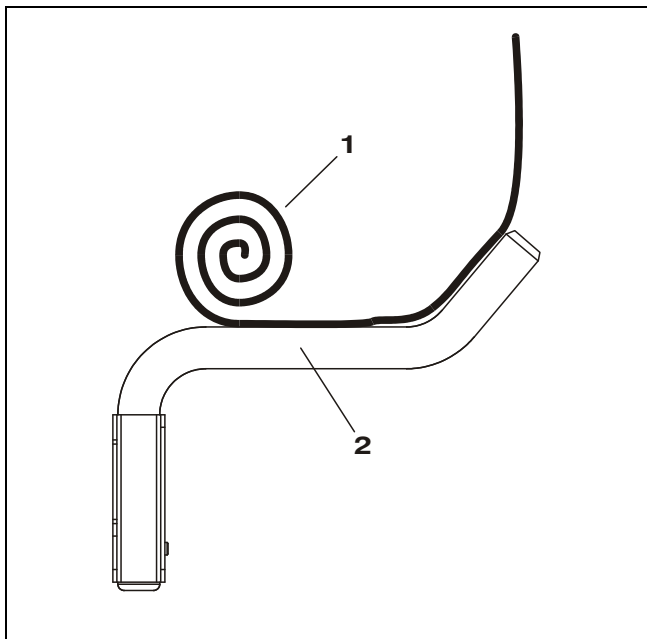

### Removing Rug From Display Arm.

1. Roll Rug onto Rug Carrier while Elevating Platform
2. Rug Carrier in Carry Position

9. Remove the rug from the Rug Carrier Accessory. If required, use an assistant to unload the rug from the Rug Carrier Accessory Arms.
10. Replace the Rug Hanger Accessory arms to the stowed position for normal operation.

### **CAUTION**

**THE RUG CARRIER ACCESSORY ARMS MUST BE LOCKED IN THE STOWED POSITION WHEN NOT IN USE.**

**EXTREME CAUTION MUST BE EXERCISED AT ALL TIMES WHILE THE RUG CARRIER ACCESSORY IS IN USE (DRIVING, RAISING AND LOWERING) TO PREVENT OBSTACLES AND PERSONNEL FROM STRIKING THE LOAD.**

**WHEN DRIVING WITH A RUG WITHIN THE RUG CARRIER ACCESSORY, THE RUG MUST BE PROPERLY SECURED TO PREVENT INADVERTENT MOTION OR MOVEMENT OF THE RUG AND MUST NOT EXCEED THE RATED CAPACITY OF THE RUG CARRIER ACCESSORY.**

**NEVER OVERLOAD THE RUG CARRIER ACCESSORY. MAXIMUM CAPACITY OF THE RUG CARRIER ACCESSORY IS 150 LBS.**

**THE COMBINED WEIGHT OF PERSONNEL, MATERIALS, EQUIPMENT PLUS ANY LOAD ON THE RUG CARRIER ACCESSORY MUST NOT EXCEED THE MAXIMUM CAPACITY OF THE PLATFORM.**

**NEVER USE A RUG CARRIER ACCESSORY THAT HAS DAMAGE OR LOOSE MOUNTINGS. IMMEDIATELY REPORT ANY DAMAGE TO APPROPRIATE PERSONNEL. DISCONTINUE USE OF THE RUG CARRIER ACCESSORY UNTIL ALL DISCREPANCIES HAVE BEEN CORRECTED.**

## SECTION 5. OPTIONAL EQUIPMENT

### 5.1 OPTIONAL EQUIPMENT

The following optional equipment is available for SP machines:

#### **Extra Power Pack (DC Battery, Charger & Case)**

An extra power pack which includes the battery, charger and molded case allows for extended use of an AM machine under high cycle conditions. One power pack can be charging while the other is in use.

#### **Lifting Hook**

The optional lifting hook is mounted at the top rear of the first mast section. The hook is used to lift the machine up or down to another level.

#### **Platform Auxiliary Power Lowering Device**

The Platform Auxiliary Power Lowering device is a switch activated, battery backed electrical circuit, designed to provide power to lower the platform in the event of loss of machine main power. This can be useful to the operator if the main battery becomes depleted while the platform is raised. Also if the on/off key switch on the ground control station is turned to the off position while the platform is still raised.

#### **Amber Beacon Light**

The revolving amber beacon flashes any time the machine power is turned on, this helps alert others of the presence and operation of the machine.

#### **Platform Motion Alarm**

The motion alarm emits a very audible beeping sound which is activated anytime the platform is in motion (ascending or descending).

#### **Foot-Operated Platform Controller**

This device is mounted on the platform floor at the rear of the platform. It contains two separate pedal switches mounted in a protective housing. The switches labeled UP and DOWN allow the operator to operate the lift up and lift down functions with either foot, while pressing the function enable button on the platform control panel.

#### **Rug Carrier Accessory**

The rug carrier accessory is intended for use in hanging and removal of rugs in hanging display racks. The rug carrier accessory consists of two pivoting arms mounted to the platform left side rails.

## **SECTION 5 - OPTIONAL EQUIPMENT**

---

### **Machine Cycle Counter Meter**

The Cycle Counter Meter is located on the Ground Control Station. This meter tracks the number of cycles the mast travels up and down during machine operation. This information can be used to determine maintenance intervals and other for other informational purposes when recorded over a specific period of time.

### **Platform Gate Alarm**

The platform gate alarm is available for machines equipped with the side-entry/material-tray platform with swinging gates. The gate alarm sounds if either or both gates are opened once the platform is raised approximately 2 in. from the fully lowered position.



## SECTION 6. EMERGENCY PROCEDURES

### 6.1 GENERAL INFORMATION

This section explains the steps to be taken in case of an emergency situation during operation.

### 6.2 EMERGENCY OPERATION

#### Operator Unable to Control Machine

IF THE PLATFORM OPERATOR IS PINNED, TRAPPED OR UNABLE TO OPERATE OR CONTROL THE MACHINE:

1. Other personnel should operate the machine from ground controls only as required.
2. Only qualified personnel in the platform may use the platform controls. **DO NOT CONTINUE OPERATION IF CONTROLS DO NOT FUNCTION PROPERLY.**
3. Rescue equipment can be used to remove the platform occupant. Cranes and forklifts can be used to stabilize motion of the machine.

#### Platform Caught Overhead

If the platform becomes jammed or snagged in overhead structures or equipment, rescue the platform occupant prior to freeing the machine.

### 6.3 INCIDENT NOTIFICATION

JLG Industries, Inc. must be notified immediately of any incident involving a JLG product. Even if no injury or property damage is evident, the factory should be contacted by telephone and provided with all necessary details.

USA: 877-JLG-SAFE (554-7233)

Outside USA: 717-485-5161

E-mail: [productsafety@jlg.com](mailto:productsafety@jlg.com)

Failure to notify the manufacturer of an incident involving a JLG Industries product within 48 hours of such an occurrence may void any warranty consideration on that particular machine.

#### **NOTICE**

**FOLLOWING ANY ACCIDENT, THOROUGHLY INSPECT THE MACHINE AND TEST ALL FUNCTIONS FIRST FROM THE GROUND CONTROL STATION, THEN FROM THE PLATFORM CONTROL CONSOLE. DO NOT ELEVATE PLATFORM UNTIL YOU ARE SURE THAT ALL DAMAGE HAS BEEN REPAIRED, IF REQUIRED, AND THAT ALL CONTROLS ARE OPERATING CORRECTLY.**



## **SECTION 7. GENERAL SPECIFICATIONS AND OPERATOR MAINTENANCE**

### **7.1 Introduction**

This section of the manual provides additional necessary information to the operator for proper operation and maintenance of this machine.

The maintenance portion of this section is intended as information to assist the machine operator to perform daily maintenance tasks only, and does not replace the more thorough Preventive Maintenance and Inspection Schedule included in the Service and Maintenance Manual.

Other Publications Available Specific to this Machine:

Service and Maintenance Manual:

ANSI . . . . . 3120775

Illustrated Parts Manual

ANSI . . . . . 3120776

## **7.2 General Specifications**

### **Machine Specifications**

<b>SPECIFICATION</b>	<b>12SP</b>	<b>15SP</b>
<b>Gross Machine Weight:</b> <i>(Platform Empty)</i>	1,155 lb. (525kg)	1,240 lb. (564kg)
<b>Machine Height:</b> <i>(Platform Stowed)</i>	78 in. (1.9m)	
<b>Machine Base - Overall :</b> <i>(Width x Length)</i>	33 in. (W) x 47.5 in. (L) (83.8 cm (W) x 120.6 cm (L))	
<b>Maximum Wind Speed:</b>	0 mph (0kph) - Machine rated for indoor use only	
<b>Maximum Horizontal Manual Side Force:</b> <i>(Platform fully extended with Maximum load)</i>	45 Pound Force (200 Newtons)	
<b>Maximum Hydraulic System Pressure:</b>	Pressure Relief Set to Approximately 2800 PSI (193 bar) at Factory	

## Electrical Specifications

SPECIFICATION		12SP AND 15SP	
<b>System Voltage:</b>	<b>DC Models:</b>	12 Volts DC	
<b>Battery Specifications:</b>	<b>Battery Type</b>	<b>WET/DRY COMBO (Standard)</b>	<b>AGM (VRLA) (Optional)</b>
	<b>Voltage</b>	12 Volts DC	
	<b>Amp Hour (AH) Rating</b>	105 AmpHr. @ 20 Hr.	100 AmpHr. @ 20 Hr.
	<b>Reserve Capacity</b>	165 Min.	N/A
	<b>Cold Cranking Amps</b>	625 Amps @ 0° F	N/A
	<b>Weight</b>	54 lb. (24kg)	78 lb. (35kg)
<b>Battery Charger (DC Models)</b>	<b>Input:</b>	120/240 Volts AC - 50/60 Hz - Voltage Selectable	
	<b>Output:</b>	12 Volt - 10 Amps DC - w/Auto Charge Sensing Circuit	

## SECTION 7 - GENERAL SPECIFICATIONS AND OPERATOR MAINTENANCE

### Platform Data

PLATFORM TYPE	12/15SP - PLATFORM CAPACITY	
	ANSI USA/Latin America/Japan/China	CSA (Canada)
StockPicker (28 in. X 48 in.)	500 lb. (227 kg) * 250 lb. (113kg) Front - * 250 lb. (113kg) Rear	400 lb. (182 kg) * 200 lb. (91kg) Front - * 200 lb. (91kg) Rear
Extendible 26 in. X 49 in.	500 lb. (227 kg) * 250 lb. (113kg) Front - 250 lb. (113kg) Rear	400 lb. (182 kg) * 200 lb. (91kg) Front - 200 lb. (91kg) Rear
Side Entry with Tray 23 in. X 27 in.	500 lb. (227 kg) 250 lb. (113kg) Tray - 250 lb. (113kg) Platform	400 lb. (182 kg) 200 lb. (91kg) Tray - 200 lb. (91kg) Platform
* Distribute weight evenly throughout the platform.		

SPECIFICATION	12SP	15SP
<b>Occupants:</b> <i>(Persons allowed in Platform)</i>	1	
<b>Platform Height - Mast Fully Extended -</b> <i>(Ground to Platform Floor):</i>	12 ft. (3.6 m)	15 ft. (4.5 m)
<b>Platform Working Height:</b> <i>(Average Size Person)</i>	18 ft. (5.4 m)	21 ft. (6.4 m)
<b>Platform Cycle Performance:</b> <i>(in seconds) (w/max. rated load)</i>	<b>Lift Up:</b>	25
	<b>Lift Down:</b>	13-20
		30
		18-25

## Machine Component Weights

SPECIFICATION		12SP AND 15SP
Platform Weight :	StockPicker Platform:	65 lb. (30 kg)
DC Voltage Battery Pack: <i>(Wet Cell)</i>		70 lb. (32 kg)

## Serial Number Locations

For machine identification, a serial number plate is affixed to the machine. The plate is located on the back of the mast, just above the mast support bracket.

### 7.3 Operator Maintenance

#### Battery

**NOTE:** This information applies to wet cell batteries only. Do not attempt to open a maintenance-free sealed battery.

The battery fluid level should be approximately 1/8" (3mm) below vent tubes. (See Illustration)

Keep cable connections clean and free of corrosion.

#### **CAUTION**

**BATTERY ACID IS HIGHLY CORROSIVE. AVOID CONTACT WITH SKIN AND CLOTHING AT ALL TIMES.**

**BATTERY ACID RELEASES AN EXPLOSIVE GAS WHILE CHARGING, ALLOW NO OPEN FLAMES, SPARKS OR LIGHTED TOBACCO PRODUCTS IN THE AREA WHILE CHARGING BATTERIES. CHARGE BATTERIES ONLY IN A WELL VENTILATED AREA.**

**ADD ONLY DISTILLED WATER TO BATTERIES. WHEN ADDING DISTILLED WATER TO THE BATTERIES, A NON-METALLIC CONTAINER AND/OR FUNNEL MUST BE USED.**

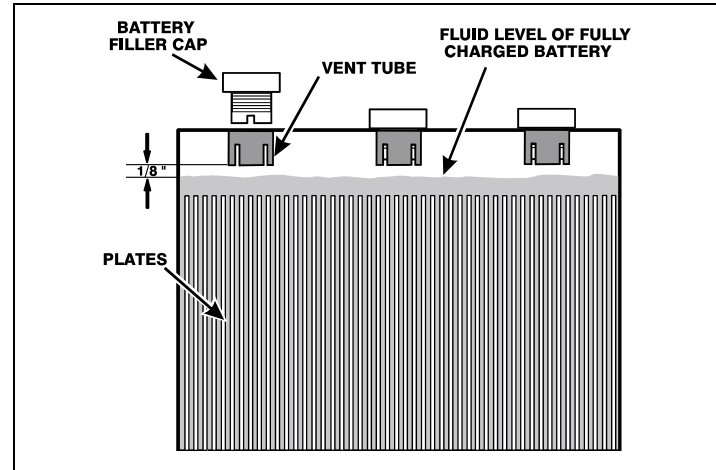

**Battery Fluid Level**

- |                       |                |
|-----------------------|----------------|
| 1. Battery Filler Cap | 3. Fluid Level |
| 2. Vent Tube          | 4. Cell Plates |



## Lubrication

### Hydraulic Oil (HO)

HYDRAULIC SYSTEM OPERATING TEMPERATURE RANGE	SAE VISCOSITY GRADE
+0°F to +180°F (-18°C to -83°C)	10W
+0°F to +210°F (-18°C to +99°C)	10W-20, 10W-30
+50°F to +210°F (+10°C to +99°C)	20W-20

Hydraulic oils must have anti-wear qualities at least to API Service Classification GL-3, and sufficient chemical stability for mobile hydraulic system service. JLG Industries, recommends Mobilfluid 424 hydraulic oil, which has an SAE viscosity of 10W-30 and a viscosity index of 152.

For cold weather applications, i.e. when temperatures remain consistently below +20°F (-7°C) JLG recommends using Mobil DTE 13 hydraulic oil.

Aside from JLG recommendations, it is not advisable to mix oils of different brands or types, as they may not contain the same required additives or be of comparable viscosities. If use of hydraulic oil other than Mobilfluid 424 is desired, contact JLG Industries for proper recommendations.

**Table 7-1. - Lubrication Specifications**

KEY	SPECIFICATIONS
MPG -	Multipurpose Grease having a minimum dripping point of 350° F. Excellent water resistance and adhesive qualities, and being of extreme pressure type. (Timken OK 40 pounds minimum.)
EPGL -	Extreme Pressure Gear Lube (oil) meeting API service classification GL-5 or MIL-Spec MIL-L-2105.
HO -	Hydraulic Oil. ISO-Vg grade 32, 46.
CL -	Chain Lube. Use a good quality chain lubricant

**NOTE:** Refer to Lubrication Chart, Table 7-2. on page 7-9 for specific lubrication locations on machine.

## SECTION 7 - GENERAL SPECIFICATIONS AND OPERATOR MAINTENANCE

---

### Lubrication Points (See Table 7-2. on page 7-9)

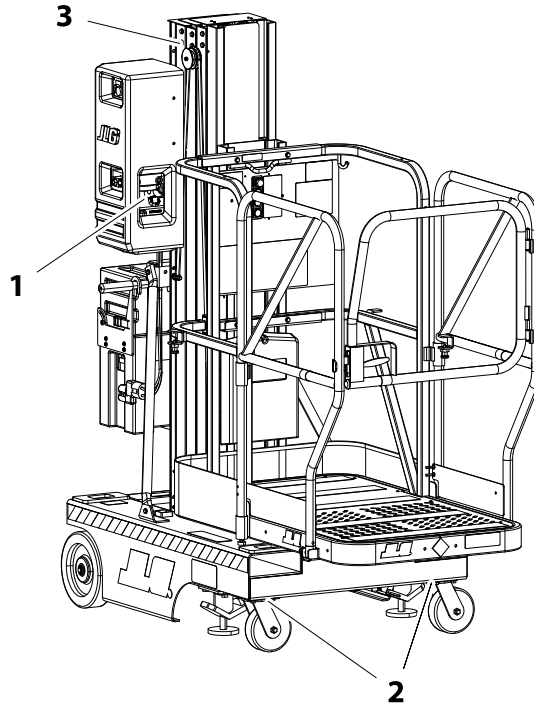

## SECTION 7 - GENERAL SPECIFICATIONS AND OPERATOR MAINTENANCE

**Table 7-2. Lubrication Intervals for Various Components**

ITEM	COMPONENT	NO/TYPE LUBE POINTS	LUBE/METHOD	INTERVAL HOURS				COMMENTS
				3 MOS. or 150 Hrs.	6 MOS. or 300 Hrs.	1 YR. or 600 Hrs.	2 YRS. or 1200 Hrs.	
1	Hydraulic Oil	Fill To Line on Reservoir 5 Qt. (4.3 L) Reservoir	HO - Check Hyd. Oil Level HO - Change Hyd. Oil				✓	Check Hyd. Oil after every 10 hrs. of operation. Change Hyd. Oil after every 1200 hrs. of operation.
2	Swivel Raceways	2 - Front Casters	MPG - Pressure Gun		✓			
3	Mast Chains *	2 - Per Section	CL - Brush or Spray	✓				Inspect, lubricate if dry or rusting.
<p>* Applies Only to Mast Sections with Chains.</p> <p>Key to Lubricants: <b>MPG</b> - Multipurpose Grease  <b>HO</b> - Hydraulic Oil - ISO-Vg grade 32, 46  <b>CL</b> - Chain Lube. Use a good quality chain lubricant</p>								
<p>Notes: 1. Be certain to lubricate like items on each side of the machine.  2. Recommended lubricating intervals are based on normal use. If machine is subjected to severe operating conditions, such as a high number of cycles, location, corrosive/dirty environment, etc., user must adjust lubricating requirements accordingly.  3. Lubricating intervals are calculated on 50 hours of machine operation a week.  4. Prior to checking hydraulic oil level, operate machine through one complete cycle of lift function (full up and down). Failure to do so will result in incorrect oil level reading on the hydraulic reservoir.</p>								

### **7.4 SUPPLEMENTAL INFORMATION**

The following information is provided in accordance with the requirements of the European Machinery Directive 2006/42/EC and is only applicable to CE machines.

For electric powered machines, the equivalent continuous A-Weighted sound pressure level at the work platform is less than 70dB(A).

For combustion engine powered machines, guaranteed Sound Power Level (LWA) per European Directive 2000/ 14/EC (Noise Emission in the Environment by Equipment for Use Outdoors) based on test methods in accordance with Annex III, Part B, Method 1 and 0 of the directive, is 109 dB.

The vibration total value to which the hand-arm system is subjected does not exceed 2,5 m/s<sup>2</sup>. The highest root mean square value of weighted acceleration to which the whole body is subjected does not exceed 0,5 m/s<sup>2</sup>.







An Oshkosh Corporation Company

# TRANSFER OF OWNERSHIP

## To Product Owner:

If you now own but ARE NOT the original purchaser of the product covered by this manual, we would like to know who you are. For the purpose of receiving safety-related bulletins, it is very important to keep JLG Industries, Inc. updated with the current ownership of all JLG products. JLG maintains owner information for each JLG product and uses this information in cases where owner notification is necessary.

Please use this form to provide JLG with updated information with regard to the current ownership of JLG products. Please return completed form to the JLG Product Safety & Reliability Department via facsimile or mail to address as specified below.

Thank You,  
Product Safety & Reliability Department  
*JLG Industries, Inc.*  
13224 Fountainhead Plaza  
Hagerstown, MD 21742  
USA  
Telephone: +1-717-485-6591  
Fax: +1-301-745-3713

**NOTE:** Leased or rented units should not be included on this form.

Mfg. Model: \_\_\_\_\_

Serial Number: \_\_\_\_\_

Previous Owner: \_\_\_\_\_

Address: \_\_\_\_\_

Country: \_\_\_\_\_ Telephone: (\_\_\_\_) \_\_\_\_\_

Date of Transfer: \_\_\_\_\_

Current Owner: \_\_\_\_\_

Address: \_\_\_\_\_

Country: \_\_\_\_\_ Telephone: (\_\_\_\_) \_\_\_\_\_

**Who in your organization should we notify?**

Name: \_\_\_\_\_

Title: \_\_\_\_\_









3120774



An Oshkosh Corporation Company

***Corporate Office***

***JLG Industries, Inc.***

***1 JLG Drive***

***McConnellsburg, PA 17233-9533 USA***

***☎ (717) 485-5161 (Corporate)***

***☎ (877) 554-5438 (Customer Support)***

***☎ (717) 485-6417***

***Visit our website for JLG Worldwide Locations.***

***[www.jlg.com](http://www.jlg.com)***