

DEWALT®



Instruction Manual

DXWP62383

DXWP62381

DXWP62389

DXWP62583

DXWP62581

DXWP62783

DXWP62781

DXWP62183

DXWP62181

Aluminum, Stainless Steel and Cast Iron Submersible Sump Pump



www.DEWALT.com

If you have questions or comments, contact us.

1-855-222-3841

customer.service@pedrollo-usa.com



Index	
Content	Page #
Components	2
Safety Guidelines	3
Description	4
Specifications	4
Installation	5
Operation	6
Maintenance	6
Troubleshooting	7
Performance	8
Parts	9
Notes	10
Warranty	11

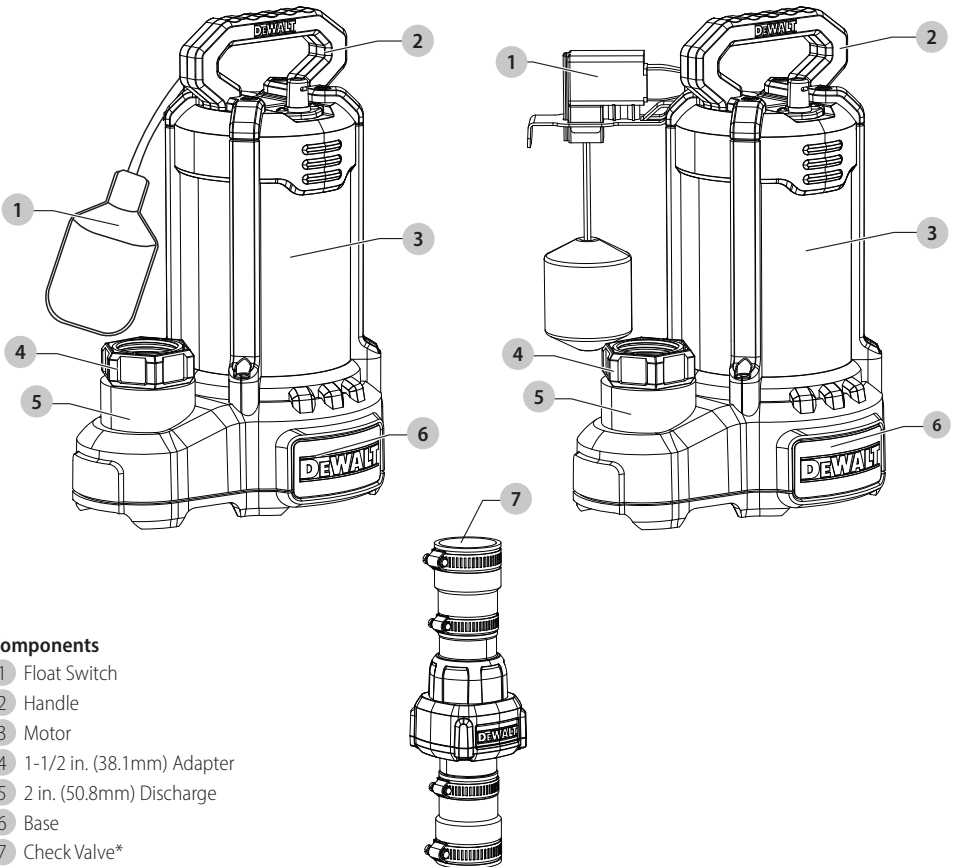

Components

- 1 Float Switch
- 2 Handle
- 3 Motor
- 4 1-1/2 in. (38.1mm) Adapter
- 5 2 in. (50.8mm) Discharge
- 6 Base
- 7 Check Valve*

*Included with DXWP62389 or sold separately under part no. DXWPCV69512



Safety Guidelines

Carefully read, understand and follow all safety instructions in this manual. Retain this manual for future reference.



This is the safety alert symbol. When you see this symbol, look for one of the following signal words.

Important

Read these warnings carefully. Know the application and limitations of this pump. Failure to follow these warnings could result in serious bodily injury and/or property damage.

⚠ DANGER: Indicates a hazardous situation which, if not avoided, **will** result in **death or serious injury**.

⚠ WARNING: Indicates a hazardous situation which, if not avoided, **could** result in **death or serious injury**.

⚠ CAUTION: Indicates a hazardous situation which, if not avoided, **could** result in **minor or moderate injury**.

⚠ NOTICE: Indicates to address practices **not related to personal injury**.

⚠ WARNING RISK OF ELECTRICAL SHOCK:

Disconnect and lockout power supply before removing existing pump or installing or servicing this pump.

⚠ WARNING RISK OF ELECTRICAL SHOCK: This pump is supplied with a grounding conductor and grounding type attachment plug. To reduce the risk of electric shock, connect only to a properly grounded GFCI receptacle.

⚠ WARNING RISK OF ELECTRICAL SHOCK: Connect only to a receptacle that is properly rated for the voltage and amperage of this pump.

⚠ WARNING: The installation of this pump must be in accordance with the National Electric Code (NEC), Uniform Plumbing Code (UPC), International Plumbing Code (IPC) as well as all applicable local codes and ordinances.

⚠ WARNING: Do not install this pump in any location classified as hazardous by the National Electrical Code, ANSI/NFPA70.

⚠ DANGER: Do not use this pump to pump corrosive, flammable or explosive fluids such as gasoline, kerosene, etc. Do not use this pump in flammable or explosive environments. Use only with liquids compatible with pump component materials. Using the pump with these liquids will void the warranty.

⚠ WARNING RISK OF ELECTRICAL SHOCK: This pump has not been investigated for use in swimming pool or marine areas.

⚠ WARNING RISK OF ELECTRICAL SHOCK: Do not use the power cord to remove or lower the pump into the basin. The cord may pull apart exposing bare wires which could cause a fire or electrical shock. Use the handle supplied with the pump for installing and removing the pump from the basin.

⚠ WARNING: Don't expose the pump to freezing temperatures. Discharge lines exposed to freezing temperatures should be positioned with a downward slope to prevent freezing.

⚠ WARNING: All wiring and electrical connections must be performed by a qualified electrician.

⚠ WARNING: Make certain that an electrical outlet is within the reach of the power supply cord. **DO NOT USE AN EXTENSION CORD.**

⚠ WARNING: Do not run the pump dry. This pump relies on water for lubrication and cooling. Running the pump dry can cause the pump to overheat and risks the possibility of burns to anyone that handles the pump. Running the pump dry will void the warranty.

⚠ WARNING: Do not use this pump for potable/drinking water. Use only in applications for which the pump is designed.

⚠ WARNING: According to the state of California (Prop 65), this product contains chemicals known to the state of California to cause cancer and birth defects or other reproductive harm.

⚠ WARNING: DO NOT UNDER ANY CIRCUMSTANCES REMOVE THE GROUND PIN. The 3-prong plug must be inserted into a mating 3-prong grounded receptacle. If the installation does not have such a receptacle, it must be changed to the proper type, wired and grounded in accordance with the National Electrical Code and all applicable local codes and ordinances.

⚠ WARNING: This pump is not intended to pump water softener discharge (brine) or condensate from high efficiency appliances. These liquids are corrosive and could cause damage to the pump and will void the warranty.

⚠ WARNING: Keep hands clear of suction and discharge openings. To prevent injury, never insert fingers into pump while it is plugged in.

⚠ WARNING: Do not handle this pump with wet hands or while standing on wet or damp surfaces or in water.

⚠ CAUTION: If a flexible discharge hose is used, make certain the pump is secured in the basin to prevent movement. Failure to secure the pump could result in flooding from switch malfunction.

⚠ CAUTION: The pump motor is equipped with an automatic resetting thermal protector and will shut down the pump in an overheat situation. Take caution as the pump may restart unexpectedly once the motor cools.

⚠ NOTICE: This pump is not designed as a waterfall, pond or fountain pump. Use of this pump for waterfalls, ponds or fountains will void the warranty.

Description

This sump pump is designed to remove ground water from residential sump basins. The motor is oil cooled and hermetically sealed. A float switch is provided for automatic operation and is equipped with a 10 ft., 3-prong grounding type power cord.

Specifications

	DXWP62383 DXWP62381	DXWP62389	DXWP62583 DXWP62581	DXWP62783 DXWP62781	DXWP62183 DXWP62181
Check Valve	Sold Separately	Included	Sold Separately	Sold Separately	Sold Separately
HP	1/3	1/3	1/2	3/4	1
Volts	115 Volt AC	115 Volt AC	115 Volt AC	115 Volt AC	115 Volt AC
Amps	6.5	6.5	10	10.7	12
Hz	60	60	60	60	60
Phase	1	1	1	1	1
Discharge Size	2 in. (50.8mm) FNPT	2 in. (50.8mm) FNPT	2 in. (50.8mm) FNPT	2 in. (50.8mm) FNPT	2 in. (50.8mm) FNPT
Adapter Size	1-1/2 in. (38.1mm) NPT	1-1/2 in. (38.1mm) NPT	1-1/2 in. (38.1mm) NPT	1-1/2 in. (38.1mm) NPT	1-1/2 in. (38.1mm) NPT
Max. Solids Handling	1/2 in. (12.7mm)	1/2 in. (12.7mm)	1/2 in. (12.7mm)	1/2 in. (12.7mm)	1/2 in. (12.7mm)
Liquid Temp. Range	35°F - 120°F (1.67°C - 48.9°C)	35°F - 120°F (1.67°C - 48.9°C)	35°F - 120°F (1.67°C - 48.9°C)	35°F - 120°F (1.67°C - 48.9°C)	35°F - 120°F (1.67°C - 48.9°C)
Cord Length	10 ft. (3.05m)	10 ft. (3.05m)	10 ft. (3.05m)	10 ft. (3.05m)	10 ft. (3.05m)
Pump Motor Cover	Aluminum	Aluminum	Aluminum	Aluminum	Aluminum
Motor Housing Construction	Stainless Steel	Stainless Steel	Stainless Steel	Stainless Steel	Stainless Steel
Pump Base Construction	Cast Iron	Cast Iron	Cast Iron	Cast Iron	Cast Iron
Impeller	Cast Iron	Cast Iron	Cast Iron	Cast Iron	Cast Iron
Motor Shaft	Stainless Steel	Stainless Steel	Stainless Steel	Stainless Steel	Stainless Steel
Shaft Seal	Carbon/Ceramic/ Stainless Steel	Carbon/Ceramic/ Stainless Steel	Carbon/Ceramic/ Stainless Steel	Carbon/Ceramic/ Stainless Steel	Carbon/Ceramic/ Stainless Steel
Fasteners	Stainless Steel	Stainless Steel	Stainless Steel	Stainless Steel	Stainless Steel
Max Vertical Lift	25 ft. (7.62m)	25 ft. (7.62m)	35 ft. (10.7m)	37 ft. (11.3m)	34 ft. (10.4m)
Max. PSI	10.8	10.8	15.1	16.0	14.7

	DXWP62383	DXWP62389	DXWP62583	DXWP62783	DXWP62183
Switch Type	Vertical	Vertical	Vertical	Vertical	Vertical
Switch On Level (Factory Set)	7 in. (178 mm)	7 in. (178 mm)	8 in. (203 mm)	8 in. (203 mm)	8.5 in. (216 mm)
Switch Off Level (Factory Set)	2.5 in. (64 mm)	2.5 in. (64 mm)	2.5 in. (64 mm)	2.5 in. (64 mm)	2.5 in. (64 mm)

	DXWP62381	DXWP62581	DXWP62781	DXWP62181
Switch Type	Tethered	Tethered	Tethered	Tethered
Switch On Level (Factory Set)	14 in. (356 mm)	15.5 in. (394 mm)	15.5 in. (394 mm)	16 in. (406 mm)
Switch Off Level (Factory Set)	5.5 in. (140 mm)	6.5 in. (165 mm)	6.5 in. (165 mm)	7.25 in. (184 mm)

Installation

⚠ WARNING: Always disconnect the power source before attempting to install, service or perform maintenance on the pump. Failure to do so may result in fatal electrical shock.

⚠ NOTICE: This pump is designed and built to give you reliable performance and long life. It will pump water automatically for years when properly installed and maintained in the proper environment.

⚠ NOTICE: A qualified electrician must perform all wiring.

Remove old pump (if necessary):

1. Ensure sure power supply is disconnected.
2. Remove old pump from the basin. If cutting existing pipe, be prepared for water to drain from piping. Inspect and replace any damaged piping. Be sure to clean all debris, dirt, rocks and sediment out of the sump basin before installing your new pump.

⚠ CAUTION: Before installing a new pump, be certain a grounded 115V AC outlet is installed within 6 ft. (1.83m) of your sump basin. DO NOT use an extension cord

Install new pump:

1. Place the pump in the bottom of the sump basin. The pump should be placed on a solid foundation. Do not place the pump directly on the ground or on sandy or rocky surfaces. Sand/silt and small stones may clog or cause damage to your pump.
2. It is highly recommended to install a full flow, swing-type check valve (Included only on model DXWP62389) on the discharge line. For ease of future removal or maintenance it is recommended to install the check valve above the cover or top of the sump basin. A new check valve will greatly increase the life of the pump. The check valve should be the same size as the pump discharge pipe.
3. Connect the pump and check valve together using PVC or ABS pipe and fittings. (See Figure 1 for typical installation). Corrugated drain hose is intended for temporary use and should not be used in a permanent installation. Although there are other types of pipe that work with this installation, PVC or ABS is recommended.
4. Continue installation from the check valve to the exterior using pipe and fittings suitable for your installation. The discharge pipe should be as short as possible used with the fewest number of fittings to minimize friction/head loss. All piping must conform to all plumbing codes.
5. Make sure the float switch operates freely from the bottom to top without coming in contact with the side of the sump basin. Contact with the side of the sump basin may cause the float to malfunction and the pump will not operate as intended.

Figure 1:

- 1 Full-flow swing type check valve*
- 2 GFCI outlet
- 3 Discharge Pipe
- 4 Sump Basin
- 5 Position pump so the float switch operates freely without touching the sides of the basin.

* (1) Included with DXWP62389 only or sold separately under part no. DXWPCV69512. Items 2, 3 & 4 are not included with all pumps.

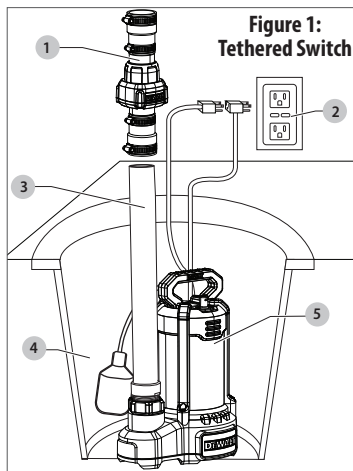
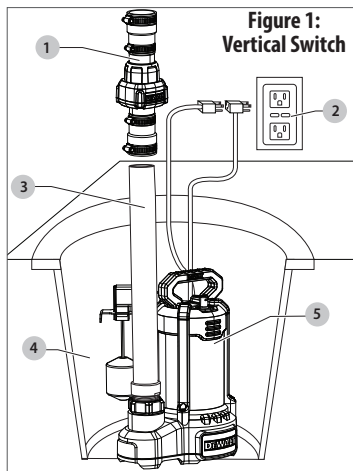

Operation

⚠ WARNING: The pump motor is thermally protected and is not recommended for pumping liquids over 120° F (48.9°C). The thermal overload protector will automatically shut down the pump in an overheat situation. The motor will reset itself once it cools down. This overload is designed as a safety device and it will fail after repeated use. Normal operation is for fluids between 35° F - 120° F (1.7°C - 48.9°C).

⚠ WARNING: Do not let the pump run dry. This pump relies on water for lubrication and cooling. Operating the pump without water may cause the motor to overheat or cause damage to seals or internal parts. It may also shorten the life of your pump.

Automatic Operation:

1. Connect the piggy-back plug of the float switch into a 115 volt grounded GFCI receptacle. See Figure 2.
2. Connect the pump plug into the back of the piggy-back float switch plug. See Figure 2.
3. Test your installation by filling the basin with water. Observe the float switch through at least one complete cycle to ensure it operates freely and does not contact the sides of the basin. If necessary, adjust the float switch or reposition the pump to ensure proper operation.
4. DeWalt sump pumps are equipped with an (A) anti-airlock hole. A stream of water will emit from this hole when the pump is operating. This is a normal feature of this pump. The anti-airlock hole should be cleaned periodically to prevent the pump from becoming air locked. See Figure 3.

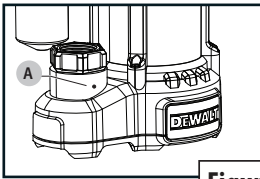

Figure 3

Manual Operation:

1. For manual operation or if the float switch has malfunctioned, the pump can be operated manually by bypassing the float switch. The pump power cord can be disconnected from the piggy-back float switch plug and connected directly to the receptacle. This will bypass the float switch and the pump will run continuously. During manual operation the pump should be monitored at all times to ensure the pump does not run dry. When pumping is complete disconnect from receptacle.

Maintenance

⚠ WARNING: Risk of electric shock. Always disconnect the power supply before attempting to install, service or perform maintenance on the pump.

⚠ WARNING: All repairs must be made by a qualified technician.

⚠ CAUTION: This submersible pump contains oil which may become pressurized and hot under normal operating conditions – allow the pump to cool for 2-3 hours before servicing.

1. The pump motor is hermetically sealed in the housing and does not require any service. Disassembly of the motor housing or modification of the power cord voids the warranty.
2. Periodically check the sump basin for accumulation of mud, silt, sand and foreign objects. Clean the basin as needed to prevent damage or clogging of the pump.
3. Periodically check the intake for obstructions. Clean if necessary.
4. Periodically inspect and clean the anti-airlock hole.
5. Inspect the float switch for any accumulated sediment or debris that may inhibit it from operating properly. Clean if necessary.
6. Inspect the power cord for signs of damage or wear. Do not operate the pump if the cord is damaged or worn.
7. In applications where the pump may not activate for extended periods of time, it is recommended to cycle the pump at least once per month to ensure the pumping system is working properly when needed.

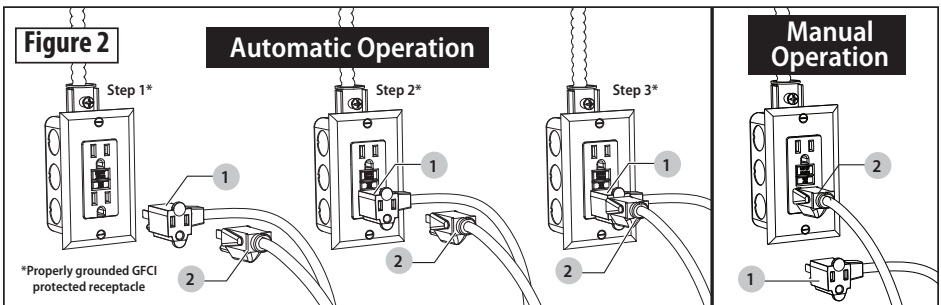

Components

- 1 Float Switch Plug (piggy-back)
- 2 Pump Plug

Troubleshooting

Problem	Possible Causes	How To Correct
If the pump does not start or run	Pump is not plugged in; switch or breaker is turned off	Plug pump in or turn on switch/breaker
	Check for blown fuses or tripped circuit breakers or tripped GFCI outlets	Replace fuse, reset circuit breaker, reset GFCI outlet
	Float switch is defective	Check and replace if necessary
	Motor thermal protector tripped	Allow pump to cool. Pump will reset automatically.
	Float switch is stuck or obstructed	Remove obstruction or position pump so the float switch will operate freely.
The pump starts and stops too often	Back-flow of water from discharge hose/pipe	Install or replace check valve. If check valve is installed, check for broken or leaking valve and replace if necessary.
	Float switch is defective	Replace float switch
If the pump runs, but moves little or no water	Clogged discharge hose/pipe	Remove clog
	Frozen discharge hose/pipe	Allow hose/pipe to thaw
	Pump is air locked	Check airlock hole for clogs and clean if necessary
	Low line voltage	Check wire size and increase if necessary
	Check valve is stuck in the closed position	Inspect, repair or replace if necessary
	Check valve is installed backwards	Make sure check valve is installed in the correct direction of flow
	Clogged intake screen	Clean or replace screen
	Worn, damaged or clogged pump parts	Inspect for wear, damage or clog and clean or replace part if necessary
Discharge height exceeds pump capacity	See performance chart for pump limitations	
Pump does not shut off	Float switch is obstructed or stuck	Remove obstruction
	Defective float switch	Replace float switch

Performance

Discharge height and/or pipe size and length will reduce the pump output performance. It is recommended to use the same size or larger pipe as the pump discharge for optimum performance. Performances below achieved using 2" PVC pipe.

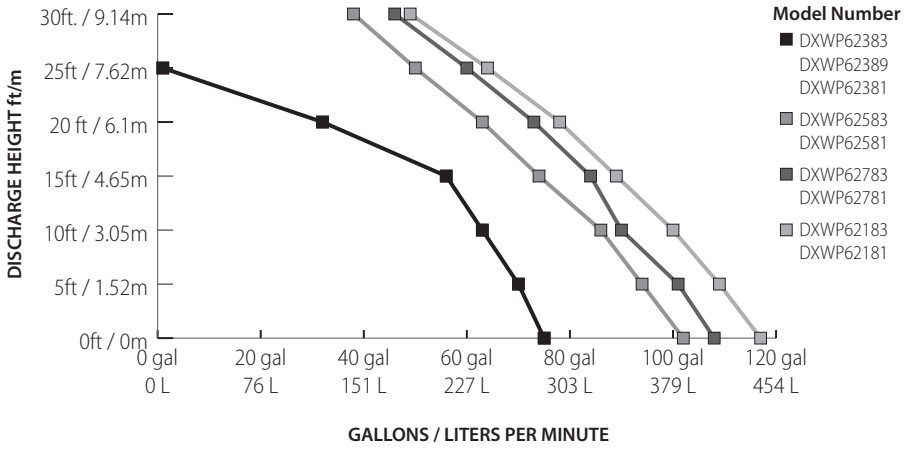

Gallons Per Minute At Discharge Height

Model	0 ft.	5 ft.	10 ft.	15 ft.	20 ft.	25 ft.	30 ft.	35 ft.	Max Lift
DXWP62383 DXWP62389 DXWP62381	75	70	63	56	27	1	-	-	25 ft.
DXWP62583 DXWP62581	102	94	86	74	63	50	38	25	35 ft.
DXWP62783 DXWP62781	108	100	90	84	73	60	46	34	37 ft.
DXWP62183 DXWP62181	117	109	100	89	78	64	49	35	34 ft.

Liters Per Minute At Discharge Height

Model	0 m	1.52 m	3.05 m	4.65 m	6.1 m	7.62 m	9.14 m	10.7 m	Max Lift
DXWP62383 DXWP62389 DXWP62381	284	265	238	212	102	4	-	-	7,6 m
DXWP62583 DXWP62581	386	356	326	280	238	189	144	95	10,7 m
DXWP62783 DXWP62781	409	379	341	318	276	227	174	129	11,3 m
DXWP62183 DXWP62181	443	413	379	337	295	242	185	132	10,4 m

Replacement Parts

For parts, contact customer support at 855-222-3841 or customer.service@pedrollo-usa.com

Reference	Description	DXWP62383 DXWP62381	DXWP62389	DXWP62583 DXWP62581	DXWP62783 DXWP62781	DXWP62183 DXWP62181
1	Handle	ADW100000	ADW100000	ADW100000	ADW100000	ADW100000
2	Power Cord	98101040	98101040	98101040	98101040	98101014
3	Shaft Seal	T00900037/38	T00900037/38	T00900037/38	T00900037/38	T00900037/38
4	Impeller	ADW100001	ADW100001	ADW100002	ADW100003	ADW100003
5	Adapter	G81200164	G81200164	G81200164	G81200164	G81200164
9	Check Valve	Not Included	DXWPCV69512	Not Included	Not Included	Not Included

*If motor fails, replace entire pump.

Reference	Description	DXWP62383	DXWP62389	DXWP62583	DXWP62783	DXWP62183
6	Vertical Float Switch Bracket	C30010195	C30010195	C30010195	C30010195	C30010195
7	Vertical Float Switch	F20010006	F20010006	F20010006	F20010006	F20010005

Reference	Description	DXWP62381	DXWP62581	DXWP62781	DXWP62181
8	Tethered Float Switch	O10100001	O10100001	O10100006	O10100006

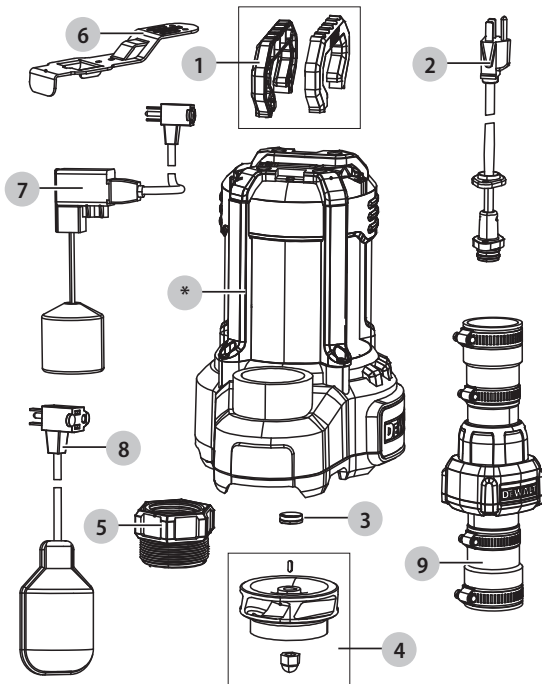

*Not available for replacement

Notes:

Limited Warranty:

Manufacturer warrants the products specified in this warranty to be free from defects in material or workmanship for ten (10) years from date of purchase. During the time period and subject to the terms and conditions, manufacturer will repair or replace to the original user or consumer any portion of this product which proves to be defective due to materials or workmanship. At all times, manufacturer shall have and possess the sole right and option to determine whether to repair or replace defective equipment, parts or components. Manufacturer has the option to inspect any product returned under warranty to confirm that the warranty applies before repair or replacement under warranty is approved. This warranty sets forth manufacturer's sole obligation and purchaser's exclusive remedy for defective product. For warranty consideration, call **855-222-3841**

or customer.service@pedrollo-usa.com.

Warranty Period:

If, within the duration of product use by the original user, this product proves to be defective due to materials or workmanship, the product shall be repaired or replaced at the manufacturer's option, subject to the terms and conditions set forth in this warranty statement. Proof of purchase is required for warranty consideration. In the absence of suitable proof of the purchase date, the effective period of this warranty is 12 months from the product's date of manufacture. If a warranty replacement pump is provided to the customer, the warranty of the replacement pump will be subject to the original purchase date of the original pump.

Labor, ETC, Costs:

The manufacturer shall IN NO EVENT be responsible or liable for the cost of field labor or other charges incurred by any customer in removing and/or affixing any product, part, or component thereof.

Product Improvements:

The manufacturer reserves the right to change or improve its products or any portions thereof without being obligated to provide such a change or improvement for units sold and/or shipped prior to such change or improvement.

General Terms and Conditions:

This warranty shall not apply to damage due to acts of God, normal wear and tear, normal maintenance services and the parts used in connection with such service, lightning or conditions beyond the control of the manufacturer, nor shall it apply to products which, in the sole judgment of the manufacturer, have been subject to negligence, abuse, accident, misapplication, tampering, alteration; nor due to improper installation, operation, maintenance or storage; nor to excess of recommended maximums as set forth in the instructions.

General Terms and Conditions - Cont:

Warranty will be VOID if any of the following conditions are found:

1. Product is used for purposes other than those for which it was designed and manufactured. Pump has been used for pumping liquids above 120°F (48.9°C).
2. Product is not installed in accordance with applicable codes, ordinances, and good trade practices.
3. Product is connected to voltage other than indicated on nameplate or labels.
4. Pump has been exposed to but not limited to the following: sand, gravel, cement, grease, plaster, mud, tar, oil, gasoline, solvents or other abrasive or corrosive substances.
5. Pump has been allowed to operate dry (liquid supply cut off).

Disclaimer:

Any oral statements about the product made by the seller, the manufacturer, the representatives, or any other parties do not constitute warranties, shall not be relied upon by the user, and are not part of the contract for sale. Seller's and the manufacturer's only obligation, and buyer's only remedy, shall be the replacement and/or repair by the manufacturer of the product as described above. **NEITHER SELLER NOR THE MANUFACTURER SHALL BE LIABLE FOR ANY INJURY, LOSS OR DAMAGE, DIRECT, INCIDENTAL OR CONSEQUENTIAL (INCLUDING, BUT NOT LIMITED TO, INCIDENTAL OR CONSEQUENTIAL DAMAGES FOR LOST PROFITS, LOST SALES, INJURY TO PERSON OR PROPERTY, OR ANY OTHER INCIDENTAL OR CONSEQUENTIAL LOSS), ARISING OUT OF THE USE OR THE INABILITY TO USE THE PRODUCT, AND THE USER AGREES THAT NO OTHER REMEDY SHALL BE AVAILABLE TO IT.** Before using, the user shall determine the suitability of the product for their intended use, and user assumes all risk and liability whatsoever in connection therewith.

THE WARRANTY AND REMEDY DESCRIBED IN THIS LIMITED WARRANTY IS AN EXCLUSIVE WARRANTY AND REMEDY AND IS IN LIEU OF ANY OTHER WARRANTY OR REMEDY, EXPRESSED OR IMPLIED, WHICH OTHER WARRANTIES AND REMEDIES ARE HEREBY EXPRESSLY EXCLUDED, INCLUDING BUT NOT LIMITED TO ANY IMPLIED WARRANTY OF MERCHANTABILITY OR FITNESS FOR A PARTICULAR PURPOSE, TO THE EXTENT EITHER APPLIES TO A PRODUCT SHALL BE LIMITED IN DURATION TO THE PERIODS OF THE EXPRESSED WARRANTIES GIVEN ABOVE.

Some states and countries do not allow the exclusion or limitations on how long an implied warranty lasts or the exclusion or limitation of incidental or consequential damages, so the above exclusion or limitations may not apply to you. This warranty gives you specific legal rights, and you may also have other rights which vary from state to state.



Dedicated Customer Support

855-222-3841

customer.service@pedrollo-usa.com

Live customer support available 7 days a week.

Manufactured under license by:

Pedrollo Group Inc.

45 Maryland Ave East

St. Paul, Minnesota 55117

© 2022 DEWALT.

DEWALT®, GUARANTEED TOUGH® and the yellow/black color scheme are trademarks for DEWALT power tools, outdoor equipment, accessories, anchors and concrete adhesives and are used under license.

Product may differ from that pictured. Does not affect function.