

OPERATOR'S SAFETY AND SERVICE MANUAL

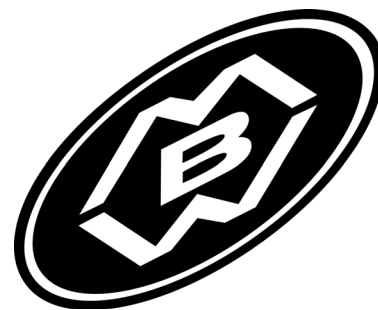

SCREEDEMON

This manual covers the following serial numbers
and higher for each model listed:

EWS500.....6020001



WET SCREED

MBW, Inc.
250 Hartford Rd • PO Box 440
Slinger, WI 53086-0440
Phone: (262) 644-5234
Fax: (262) 644-5169
Email: mbw@mbw.com
Website: www.mbw.com

MBW Europe Ltd.
Units 2&3 Cochrane Street
Bolton BL3 6BN
England, UK
Phone: +44 (0) 1204 387784
Fax: +44 (0) 1204 387797
E-mail: saleseurope@mbw.com
Website: mbweurope.com

L22331 / 12.20.C
©MBW, Inc. 2020
Printed in the USA

TABLE OF CONTENTS

SAFETY INFORMATION	1	Motor Removal	6
Introduction	1	Exciter Disassembly	6
Safety Precautions	1	Exciter Assembly	7
SPECIFICATIONS	1	Motor Installation	7
OPERATION	2	Motor Adapter Bearing Replacement	7
Introduction	2	TROUBLESHOOTING	8
Before Starting & Operating	2	Battery Interface	8
Attaching Blade	2	Electronic Throttle	8
Starting Screed	2	18v Motor	8
Stopping Screed	2	Throttle Control Circuit Board	8
Operation	3	Parts Replacement Cycles and Tolerances	9
Handle Adjustment	4	REPLACEMENT PARTS	11
Kickstand	4	Main Assembly	12
Transporting	4	Cover Assembly	14
MAINTENANCE	5	Exciter Assembly	16
Maintenance Schedule	5	Battery Mount	18
Motor Maintenance	5	Motor Mount	18
Battery Maintenance	5	Electrical Assembly	20
Cleaning	5	Screed Board Assembly	22
Checking and Replacing Shock Mounts	5	Motor Assembly	24
SERVICE	6	WARRANTY	26



WARNING



CALIFORNIA PROPOSITION 65 WARNING

Engine exhaust and some of its constituents and dust produced during the use of this product contain chemicals known in the state of California to cause cancer, birth defects, and other reproductive harm.

For more information go to **www.P65Warnings.ca.gov**

SAFETY INFORMATION

Introduction



This Safety Alert Symbol is used to call attention to items or operations which may be dangerous to those operating or working with this equipment.

The symbol can be found throughout this manual and on the unit. Please read these warnings and cautions, along with all decals, carefully before attempting to operate the unit. Make sure every individual who operates or works with this equipment is familiar with all safety precautions.

WARNING

GENERAL WARNING. Indicates information important to the proper operation of the equipment. Failure to observe may result in damage to the equipment and/or severe bodily injury or death.

CAUTION

GENERAL CAUTION. Indicates information important to the proper operation of the equipment. Failure to observe may result in damage to the equipment.

Safety Precautions



LETHAL EXHAUST GAS: An internal combustion engine discharges carbon monoxide, a poisonous, odorless, invisible gas. Death or serious illness may result if inhaled. Operate only in a properly ventilated area. **NEVER OPERATE IN A CONFINED AREA!**



DANGEROUS FUELS: Use extreme caution when storing, handling and using fuels as they are highly volatile and explosive in vapor state. Do not add fuel while engine is running. Stop and cool the engine before adding fuel. **DO NOT SMOKE!**



SAFETY GUARDS: It is the owner's responsibility to ensure that all guards and shields are in place and in working order.



IGNITION SYSTEMS: Breakerless, magneto, and battery ignition systems can cause severe electrical shocks. Avoid contacting these units or their wiring.



SAFE DRESS: Do not wear loose clothing, rings, wristwatches, etc. near machinery.

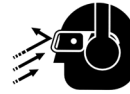

NOISE PROTECTION: Wear OSHA specified hearing protection devices.



EYE PROTECTION: Wear OSHA specified eye shields, safety glasses, and sweat bands.

FOOT PROTECTION: Wear OSHA specified steel-tipped safety shoes.

HEAD PROTECTION: Wear OSHA specified safety helmets.



OPERATOR: Keep children and bystanders off and away from the equipment.



DUST PROTECTION: Machining, crushing or handling of stone, concrete, masonry, metal and other materials may generate dust, mist and fumes containing chemicals such as silica

known to cause serious or fatal injury or illness such as respiratory disease, silicosis, cancer, birth defects, or other reproductive harm.

- Control dust, mist and fumes at the source where possible. Water should be used to control dust whenever feasible.
- Use good work practices and follow the recommendations of the manufacture, OSHA/NIOSH and other occupational trade associations.
- When hazards cannot be eliminated the operator and any bystanders should always wear a OSHA specified respirator for materials being handled.

REFERENCES: For details on safety rules and regulations in the United States, contact your local Occupational Safety and Health Administration (OSHA) office. Equipment operated in other countries must be operated and serviced in accordance and compliance with any and all safety requirements of that country. The publication of these safety precautions is done for your information. MBW does not, by the publication of these precautions, imply or in any way represent that these are the sum of all dangers present near MBW equipment. If you are operating MBW equipment, it is your responsibility to insure that such operation is in full accordance with all applicable safety requirements and codes. All requirements of the United States Federal Occupational Safety and Health Administration Act must be met when operated in areas that are under the jurisdiction of that United States Department.

Safety Decals

Carefully read and follow all safety decals. Keep them in good condition. If decals become damaged, replace as required. If repainting the unit, replace all decals. Decals are available from authorized MBW distributors. Order the decal set listed on the following page.



22159



21746

For best performance use Milwaukee Tool's M18™ REDLITHIUM™ HIGH OUTPUT™ batteries.

22158

22158 (inside cover)

EWS500

22333

WARNING
Operating, servicing and maintaining this equipment can expose you to chemicals, including engine exhaust, phthalates and lead, which are known to the state of California to cause cancer and birth defects or other reproductive harm. Avoid breathing engine exhaust. Do not operate equipment in confined areas. For more information go to www.P65Warnings.ca.gov

21820

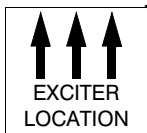

17768



17769

Safety Decals

SPECIFICATIONS

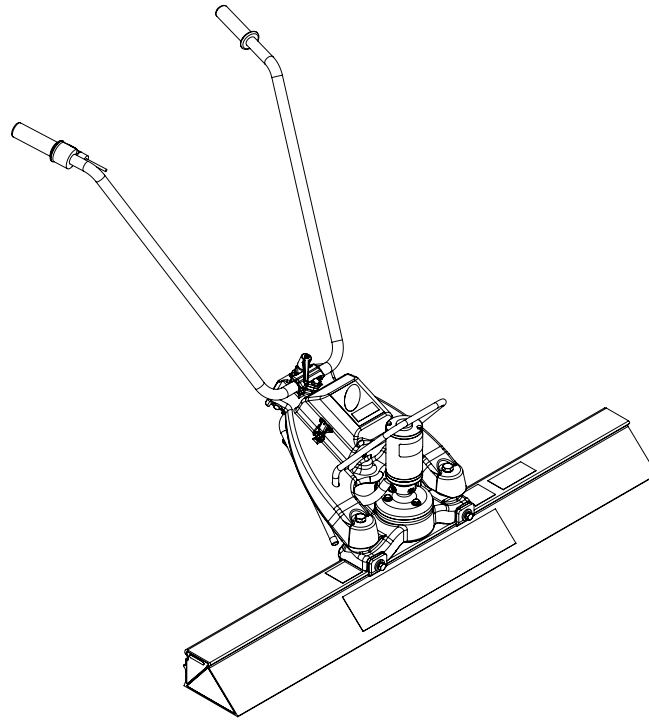

	500M
Operating Weight	33.5 lbs (15.2 kg) including 12 amp hr battery

Blade Specifications

Part #	Width	Weight
17804	4 ft (1.21 m)	8.1 lb (3.7 kg)
17806	6 ft (1.83 m)	12.1 lb (5.5 kg)
17808	8 ft (2.44 m)	16.1 lb (7.3 kg)
17810	10 ft (3.05 m)	20.1 lb (9.1 kg)
17812	12 ft (3.66 m)	24.0 lb (10.9 kg)
17814	14 ft (4.27 m)	28.0 lb (12.7 kg)
17816	16 ft (4.88 m)	32.0 lb (14.5 kg)
17818	18 ft (5.49 m)	36.0 lb (16.3 kg)
17820	20 ft (6.10 m)	40.0 lb (18.1 kg)
17824	24 ft (7.32 m)	47.9 lb (21.7 kg)

Specifications subject to change without notice

OPERATION

Introduction

MBW equipment is intended for use in very severe applications. They are available in different sizes and a selection of engines and motors.

This parts manual contains only standard parts. Variations of these parts as well as other special parts are not included. Contact your local MBW distributor for assistance in identifying parts not included in this manual.

Before Starting & Operating

- **REMEMBER!** It is the owner's responsibility to communicate information on the safe use and proper operation of this unit to the operators.
- Review ALL of the Safety Precautions listed on page 1 of this manual.
- Familiarize yourself with the operation of the machine and confirm that all controls function properly.
- Know how to STOP the machine in case of an emergency.
- Make sure hands, feet, and clothing are at a safe distance from any moving parts.

Attaching Blade

Refer to Figure 1.

1. Loosen the bolts that secure the clamps to the exciter assembly.
2. Lay the float blade on the floor with the decals facing upward.
3. Center the exciter between the "Exciter Location" decals on the float blade.

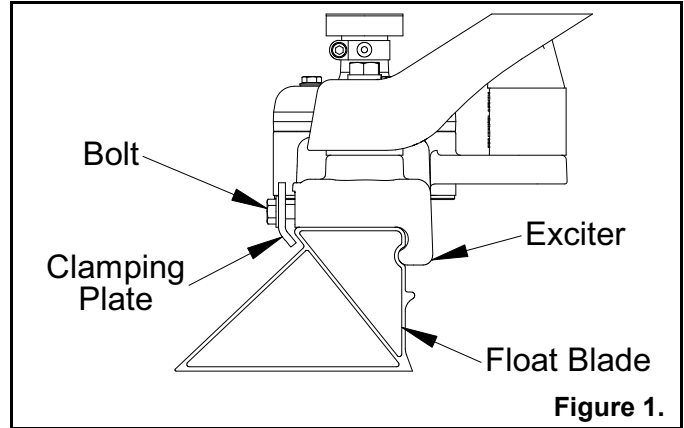

4. Tilt the exciter forward and hook the small leg of the clamping plates under the front lip of the float blade.
5. Set the exciter onto the blade so the rear part of the exciter casting lines up with the rear cavity of the float blade.
6. Tighten the clamping plate bolts.

Starting Sced

1. Insert battery and latch cover. Throttle must be fully closed when battery is inserted.
2. Turn throttle.

Stopping Sced

1. Move throttle to idle position.



WARNING



Always stop the motor before:

Replacing battery.

Before making any repairs or adjustments to the machine.

Operation

Before placing the ScreeDemon in concrete make sure the clamps securing the exciter to the float blade are tight.

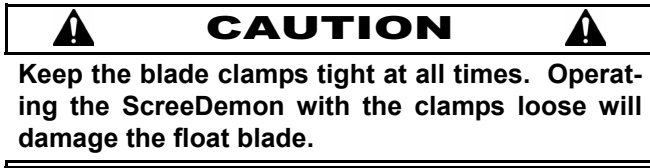

The ScreeDemon can be used with or without forms. The following describes the use of the ScreeDemon without forms.

1. Use a hand float to make a 12-18" diameter wet pad (A) at the desired grade in the four corners of the area you wish to screed. The outer extents of the wet pads should not exceed the length of the float blade being used.

NOTE: Use a laser receiver, transit level, or grade stakes to help establish the correct grade.

2. Run the ScreeDemon between the wet pads to create two parallel strips (B) that define the grade for the remainder of the wet screeding. These strips should be 12-18" wide.

3. Place one end of the float blade on each of the parallel strips (B) and screed the concrete (C) in between the strips. Be sure the float blade follows the contour of the parallel strips.

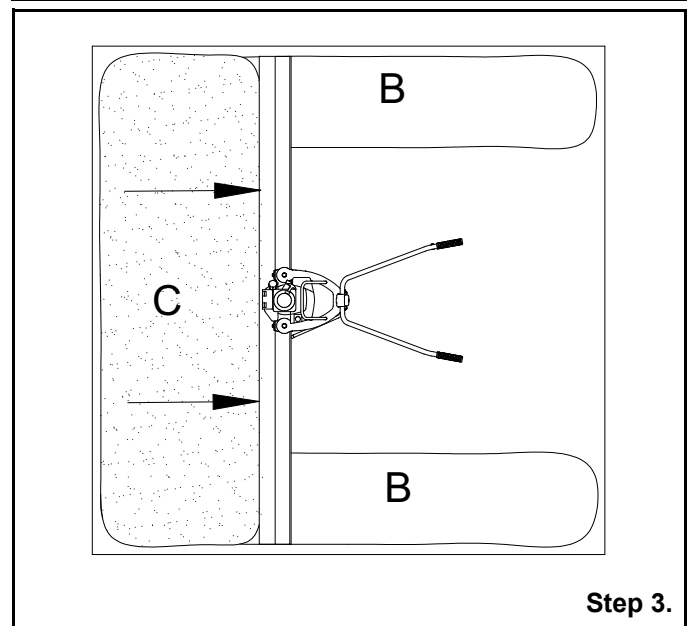
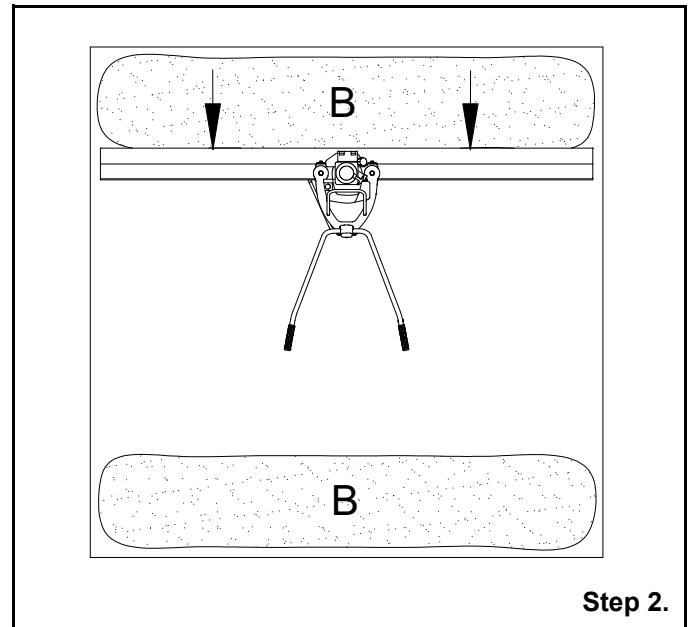
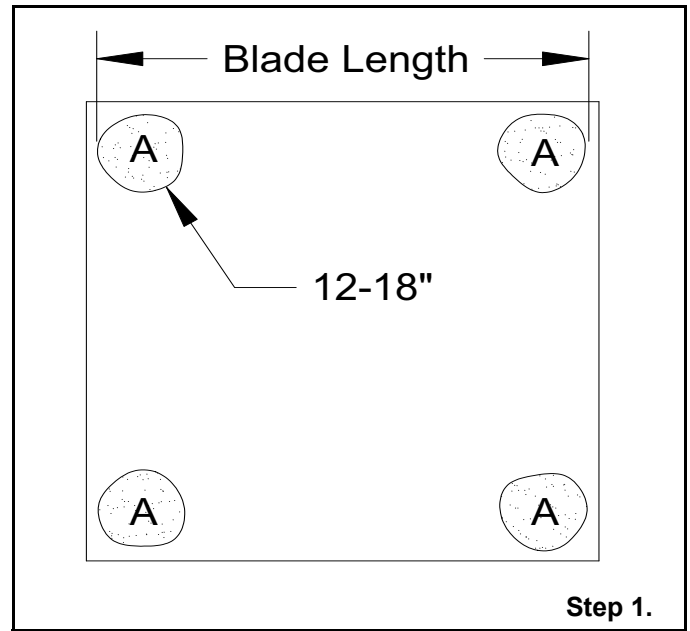

Handle Adjustment

The operator can adjust the handle on the ScreeDemon to a comfortable position.

Refer to Figure 2.

1. Loosen the handle by turning the handle adjustment lever counter-clockwise. Reorienting the lever by depressing the center button.
2. Move the handle to the desired position.
3. Tighten the handle adjustment lever.

Kickstand

The kickstand will support the ScreeDemon in an upright position when not in use.

Transporting

It is recommended to transport the ScreeDemon with the float bar removed. The float bar is more likely to be damaged if attached to the main unit during transport.

The handle can be collapsed for easier transport. See Figure 3.

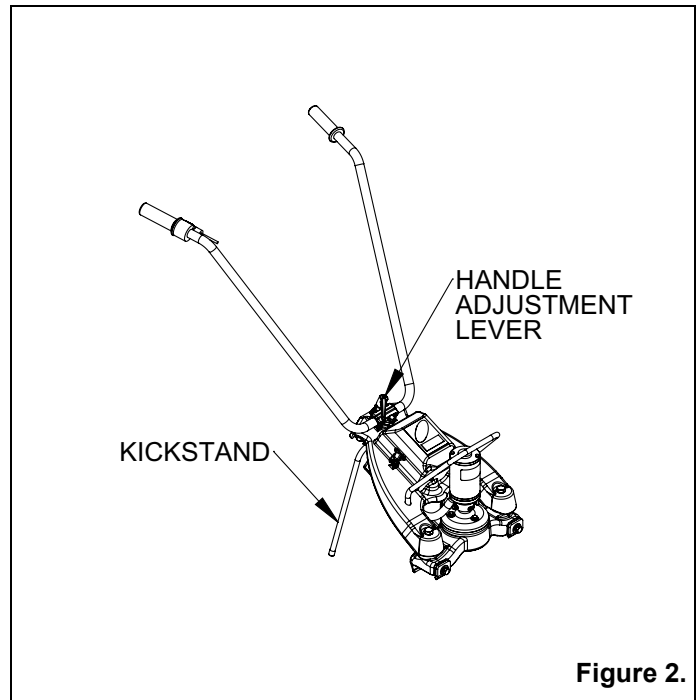

Figure 2.

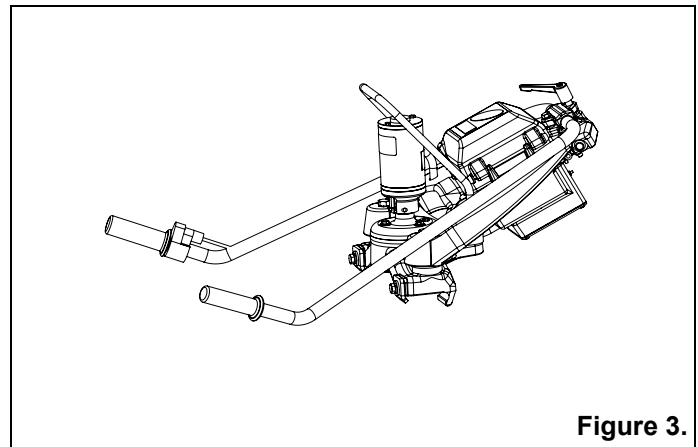

Figure 3.

MAINTENANCE



WARNING



Always exercise the stopping procedure and remove battery before servicing or lubricating the unit.

After servicing the unit, replace and fasten all guards, shields, and covers to their original positions before resuming operation.



CAUTION



Always verify fluid levels and check for leaks after changing fluids.

Do not drain oil onto ground, into open streams, or down sewage drains.

Maintenance Schedule

SYSTEM	MAINTENANCE	EACH USE	EVERY 20 HOURS	EVERY 100 HOURS	YEARLY
Hardware	Check and tighten as needed ¹		X		X
Shock mounts	Check for cracks or tears		X		
Shock mounts	Replace				X

1. Check all hardware after the first 5 hours of use, then follow the maintenance schedule.
2. Service kit pn 20192

Motor Maintenance

The electric motor is a sealed unit and no periodic maintenance is required.

Battery Maintenance

For battery care, maintenance, and charging information refer to Milwaukee Tool Technical documentation included with battery.

Cleaning

Clean any concrete from the ScreeDemon immediately after each use. DO NOT allow concrete to harden on the screed.

1. Remove battery.
2. Use a hose to remove any excess concrete. Avoid spraying water into battery compartment.

3. Remove any buildup with hard plastic bristle brush.

NOTE: DO NOT use a wire brush, hammer, or pressure washer to remove concrete from the main unit or float blade.

4. Remove the blade.
5. Insert battery, Start motor and run the exciter for about 10 seconds.
6. Remove battery.

Checking and Replacing Shock Mounts

For the best reliability, replacing the shock mounts once per year is recommended.

For instructions on replacing shockmounts, refer to 'Motor Removal' and 'Exciter disassembly, page 6.

SERVICE

Assembly and disassembly should be performed by a service technician who has been factory trained on MBW equipment. The unit should be clean and free of debris. Washing before disassembly is recommended.

- Prior to assembly, wash all parts in a suitable cleaner or solvent.
- Check moving parts for wear and failure. Refer to the Replacement Parts section in this manual for tolerance and replacement cycles.
- All shafts and housings should be oiled prior to pressing bearings. Also, ensure that the bearings are pressed square and are seated properly.
- All bearings should be replaced when rebuilding any exciter or gearbox.
- All gaskets and seals should be replaced after any disassembly.

Torque Chart

SIZE	GRADE 2	GRADE 5	GRADE 8
1/4-20	49 in·lbs	76 in·lbs	9 ft·lbs
1/4-28	56 in·lbs	87 in·lbs	10 ft·lbs
5/16-18	8 ft·lbs	13 ft·lbs	18 ft·lbs
5/16-24	9 ft·lbs	14 ft·lbs	20 ft·lbs
3/8-16	15 ft·lbs	23 ft·lbs	33 ft·lbs
3/8-24	17 ft·lbs	26 ft·lbs	37 ft·lbs
7/16-14	24 ft·lbs	37 ft·lbs	52 ft·lbs
7/16-20	27 ft·lbs	41 ft·lbs	58 ft·lbs
1/2-13	37 ft·lbs	57 ft·lbs	80 ft·lbs
1/2-20	41 ft·lbs	64 ft·lbs	90 ft·lbs
9/16-12	53 ft·lbs	82 ft·lbs	115 ft·lbs
5/8-11	73 ft·lbs	112 ft·lbs	159 ft·lbs
5/8-18	83 ft·lbs	112 ft·lbs	180 ft·lbs
3/4-16	144 ft·lbs	200 ft·lbs	315 ft·lbs
1-8	188 ft·lbs	483 ft·lbs	682 ft·lbs
1-14	210 ft·lbs	541 ft·lbs	764 ft·lbs
1-1/2-6	652 ft·lbs	1462 ft·lbs	2371 ft·lbs
M 6	3 ft·lbs	4 ft·lbs	7 ft·lbs
M 8	6 ft·lbs	10 ft·lbs	18 ft·lbs
M 10	10 ft·lbs	20 ft·lbs	30 ft·lbs

CONVERSIONS

in·lbs x 0.083 = ft·lbs

ft·lbs x 12 = in·lbs

ft·lbs x 0.1383 = kg·m

ft·lbs x 1.3558 = N·m

Motor Removal

Refer to Motor Assembly, page 24.

1. Remove battery.
2. Remove bottom cover (#5, page 20) from ScreeDemon to access wiring compartment
3. Identify and detach motor wiring (terminals 1 and 2) by inserting a small screwdriver in terminal strip hole above wire to be disconnected, and levering screwdriver to release wire clamp.
4. Loosen two pinch bolts (#8) securing motor adapter (#4) to exciter assembly (#5) and remove motor. Take care to not lose woodruff key (#1).
5. Pull hose (#3) off of motor adapter (#4) and pull wiring through.
6. Motor (#2) can be removed from adapter (#4) by removing the nuts (#6).

Exciter Disassembly

Refer to Exciter Assembly, page 16.

1. Remove battery.
2. Loosen two pinch bolts securing motor adapter to exciter assembly, and pull motor assembly off. Take care not to lose woodruff key.
3. With screed bar removed, flip machine upside down and remove three bolts securing shockmounts. Exciter assembly is now disconnected from the machine.
4. Remove the plug (#2) from the flange.
5. Use an 1/8" allen wrench to loosen the set screw (#18) inside the exciter housing, directly below the hole.
6. Stick a rod of screwdriver straight down through both holes to prevent rotation of exciter.
7. Remove the three hex head cap screws (#19) and sealing washers (#5) from the mounting flange.
8. Rotate the drive shaft (#13) counter clockwise with a screwdriver in the key way to remove the drive shaft and remove cover (#12).
9. Unthread the three shockmounts (#7) from the exciter housing (#4). Unthread the center shockmount from the exciter (#14) using a rod to prevent the rotation of the exciter as in step 8.
10. Loosen the three socket head cap screws (#20) securing the cover (#8). Back the screws off about a 1/4"

11. Gently tap on the socket head screws with a rubber mallet to push the exciter cover out of the exciter housing, then finish removing screws.
12. Remove the bearings (#6) from the exciter housing, exciter cover, and eccentric shaft.

Exciter Assembly

Refer to Exciter Assembly, page 16.

1. Press a bearing (#6) into the exciter housing (#4) and exciter cover (#8).
2. Turn the exciter housing upside down and place the threaded end of the eccentric weight (#14) into the bearing in the housing.
3. Apply a light coat of grease to the step of the cover (#8) and new o-ring (#1).
4. Apply a medium strength thread lock to the threaded holes in the cover.
5. Line up the mounting holes between the exciter housing and exciter cover and assemble. Take care not to cut the o-ring. Secure the cover with three screws (#20) and fiber washers (#11)
6. Thread the shockmounts (#7) into the housing.
7. Apply medium strength locker to threads of center shockmount and thread into eccentric.
8. Inspect the rubber seal on mount (#12). Replace if there are any tears or wear. If the seal is in good condition, skip to step 12.
9. Clean the surfaces of the mounting flange where the rubber seal was glued.
10. Apply a small bead of Loctite 426 adhesive (MBW #17885) to the lip on the engine mounting flange as shown below.



11. Place a new rubber seal onto the mounting flange and hold it for 10 seconds to allow the adhesive to set.

12. Apply medium strength locker to the threads on the end of the drive shaft (#13).
13. Position the mounting flange on the exciter assembly so that the plug hole aligns with the set screw on the exciter (#18).
14. Set the mounting flange in place while turning the drive shaft clockwise to tighten into the center shockmount.
15. Secure the flange in place with three sealing washers (#5) and screws (#19).
16. Apply medium strength locker to the set screw (#18) and install into exciter housing.
17. Replace the plug (#2).

Motor Installation

Refer to Motor Assembly, page 24.

1. Apply a light coating of grease to the ID of motor adapter (#4) and slide it onto exciter assembly (#5).
2. Connect hose (#3) between electrical compartment and motor adapter.
3. Install woodruff key (#1) into shaft of motor. Use of super glue may help retain key if needed to keep in place during assembly.
4. Apply a light coating of grease to motor shaft and install onto adapter. Take care to ensure the woodruff key remains in place and that the wiring is routed into electrical compartment.
5. Secure motor to motor adapter with washers (#7) and nuts (#6). Use a medium strength thread locker on the nuts.
6. Position motor adapter (#4) such that hose (#3) does not rub on exciter assembly.
7. Tighten motor adapter onto shaft with pinch bolts (#8). Use medium strength thread locker.
8. Connect motor wiring as shown on Electrical Assembly, page 20.

Motor Adapter Bearing Replacement

Refer to Motor Mount, page 18.

1. Follow directions 1-8 in "Exciter Disassembly"
2. Press bearing (#2) out of adapter (#1)
3. Apply light coating of Loctite 603 bearing retainer to OD of new bearing and press into place.
4. Drive shaft should slip into place.
5. Follow "Exciter Assembly" instruction steps 12-17

TROUBLESHOOTING

If your Electric ScreeDemon fails to operate as expected, the first test will always be to confirm a genuine Milwaukee battery is fully installed and charged. Removing and reinstalling the battery will reinitialize the throttle control board, clearing any faults that were detected during operation.

Battery Interface

The purpose of the battery interface is to supply 18 volts to the throttle control board. Typically the battery interface is known to be in good condition if the LED lights come on when a battery is inserted. To further trouble shoot the battery interface, follow the steps below.

Refer to Electrical Assembly, page 20.

1. Remove bottom cover (#5) over the throttle control board.
2. Identify wires at terminals 3 and 4. These are the wires which supply power to the board.
3. Insert a known-good battery.
4. Measured voltage between terminals 3 and 4 should be 18 volts, within 3 volts.
5. If voltage levels are not as described, replace battery interface.

Electronic Throttle

The purpose of the electronic throttle is to provide a signal to the throttle control board. The throttle contains a 0-5k ohm potentiometer to supply this signal. To verify function of the electronic throttle, complete the following steps.

1. Remove battery from machine.
2. Remove bottom cover from electrical enclosure.
3. Identify, and remove black, brown, and blue wires from terminals 6,7, and 8, Respectively. To remove wires, press small button above terminal with small screwdriver while gently pulling on wires.
4. The measured resistance between the blue and black wires should be 5k ohms, within 500 ohms.
5. The measured resistance between the black and brown wires should be under 20 ohms and increase smoothly to over 4.5k ohms as the throttle is turned.
6. If resistance measured isn't as described, replace electronic throttle.
7. When reinserting the wires, be very cautious that all of the conductors remain contained in the terminal.

18v Motor

The motor utilized by the MBW ScreeDemon is a permanent magnet, brushed dc motor. It is a permanently sealed and water tight motor designed to last the life of the machine and survive wash down with a low pressure hose. To verify that motor is performing to specifications, follow the steps below.

1. Loosen pinch bolts securing the motor in place and remove the motor from the exciter assembly. Take care to not lose the woodruff key.
2. Motor shaft should spin freely without binding. If shaft does not spin freely, replace motor.
3. Insert a battery and turn throttle. Motor shaft should spin counter clockwise while viewing the shaft end.
4. If motor does not spin, verify power is being supplied to it appropriately by the following steps.
5. Remove the bottom over the electronics compartment.
6. Probe wires in locations 1 and 2. While applying throttle, voltage should increase from 0 to 18 volts.
7. If proper voltage as described above and motor does not spin, replace motor.

Throttle Control Circuit Board

The MBW ScreeDemon uses an integrated circuit to control the power flow between the battery interface and the motor. This circuit board also controls the LED lights, and provides over-current protection for the motor. If over-current protection circuitry is tripped, the LED lights will blink several times before the board resets. To verify performance of the throttle control board, follow the steps below.

1. LED lights should illuminate for approximately 30 seconds after a battery is installed, while the motor is running, and approximately 30 seconds after the motor stops running. A short dip in the brightness of lights during these periods might be observed and it is normal.
2. If over-current conditions persistently occur, confirm that the eccentric weight freely rotates, no shockmounts are torn or worn, and remove any excessive concrete buildup.
3. If ScreeDemon does not operate, and tests for the battery interface, electronic throttle, and motor do not show faults, replace throttle circuit board.

Parts Replacement Cycles and Tolerances

Bearings	Replace anytime a bearing is rough, binding, discolored or removed from housing or shaft.
Hardware	Replace any worn or damaged hardware as needed. Replacement hardware should be grade 5 and zinc plated unless otherwise specified.
Safety Decals	Replace if they become damaged or illegible.
Seals & Gaskets	Replace if a leak is detected and at every overhaul or teardown.

This page intentionally left blank.

REPLACEMENT PARTS

The warranty is stated in this book on page 26. Failure to return the Warranty Registration Card renders the warranty null and void.

MBW has established a network of reputable distributors/dealers with trained mechanics and full facilities for maintenance and rebuilding, and to carry an adequate parts stock in all areas of the country. Their sales engineers are available for professional consultation. If you cannot locate an MBW distributor in your area, contact MBW or one of our Sales Branches listed below.

When ordering replacement parts, be sure to have the following information available:

- Model and Serial Number of machine when ordering MBW parts
- Part Number, Description, and Quantity
- Company Name, Address, Zip Code, and Purchase Order Number
- Preferred method of shipping

REMEMBER - You own the best! If repairs are needed, use only MBW parts purchased from authorized MBW distributors.

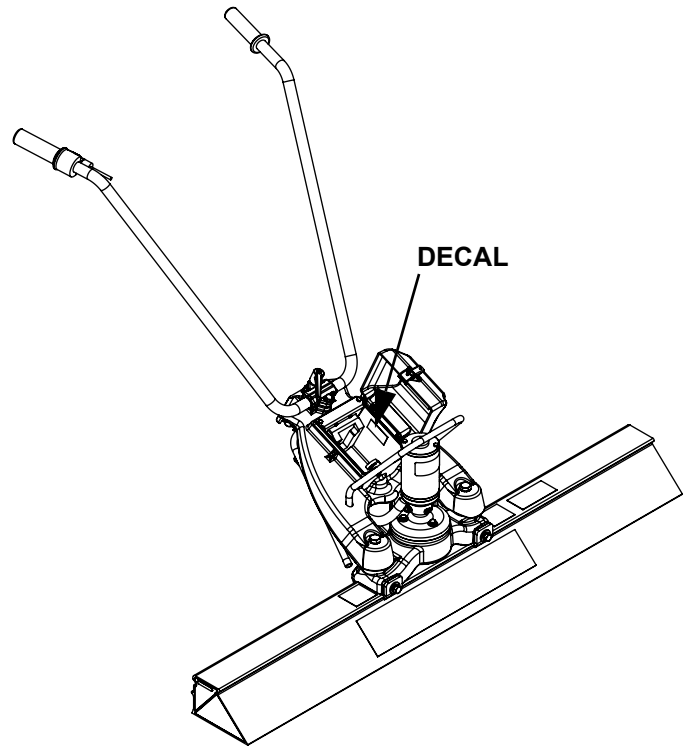

The unit's serial number can be found in the following locations:

- Decal inside battery compartment

Write Model Number here

Write Serial Number here

Contact Information

MBW, Inc.

250 Hartford Rd • PO Box 440
Slinger, WI 53086-0440
Phone: (262) 644-5234
Fax: (262) 644-5169
Email: mbw@mbw.com
Website: www.mbw.com

MBW Europe Ltd.

Units 2&3 Cochrane Street
Bolton BL3 6BN
England, UK
Phone: 44 (0) 01204 387784
Fax: 44 (0) 01204 387797

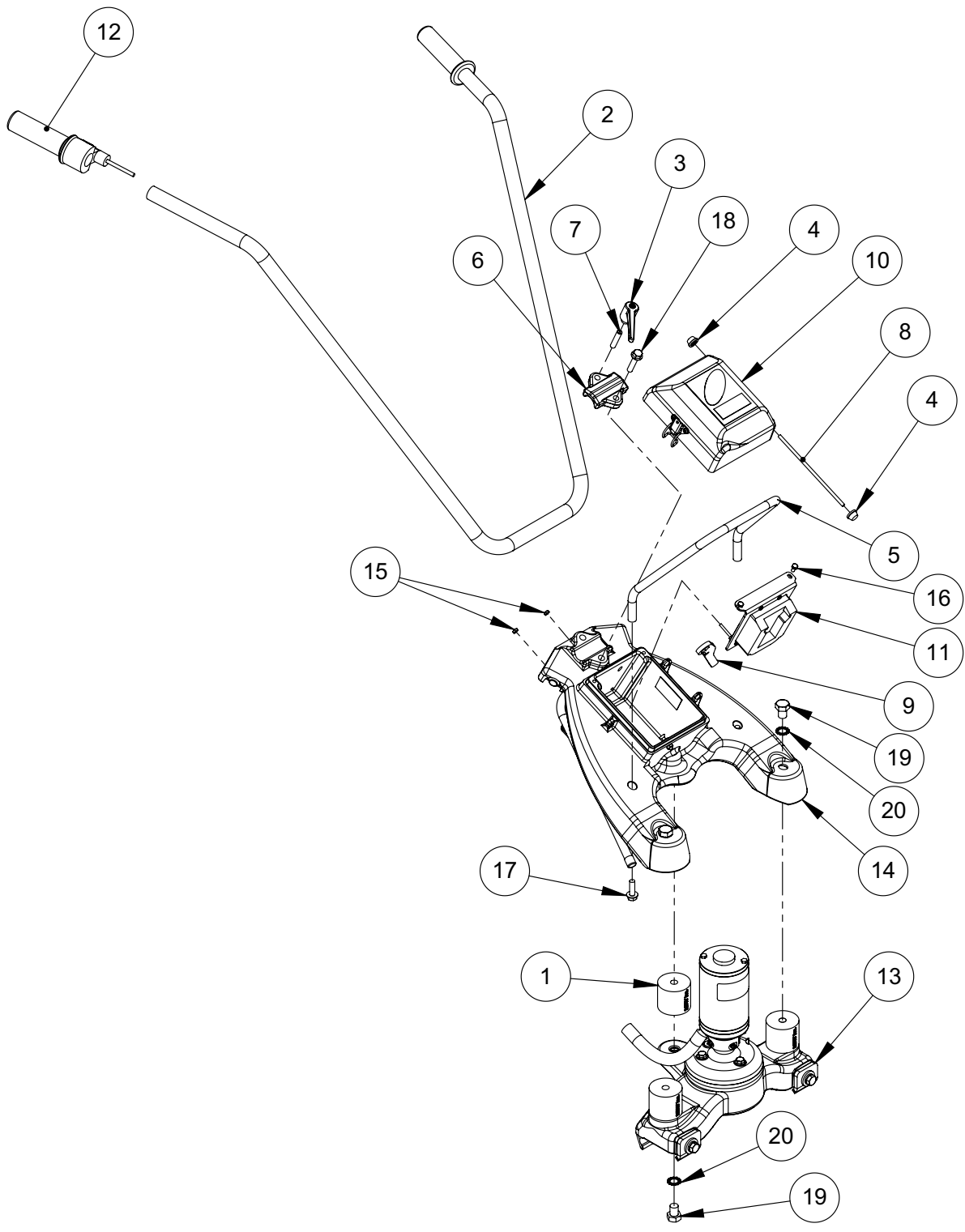

Main Assembly

ITEM	PART NO.	DESCRIPTION	QTY
1.	17170	SHOCKMOUNT, 2" OD X 1-3/4 LONG	3
2.	22408	HANDLE, 500M, MASKED	1
3.	21181	HANDLE, ADJUSTABLE, NYLON	1
4.	22112	PUSH NUT	2
5.	22117	HANDLE, LIFTING	1
6.	22119	HANDLE CLAMP, MACHINED	1
7.	21781	5/16 X 2-1/2 STUD	1
8.	22125	HINGE PIN	1
9.	22126	WRENCH, 9/16	1
10.	22135	COVER ASM	1
11.	22138	BATTERY CONNECTOR ASM	1
12.	22143	THROTTLE, ELECTRONIC	1
13.	22271	EXCITER, SCREED, M18	1
14.	22150	AFRAME, SUB ASM	1
15.	F0132HN	NUT, HEX #6-32 ZP	2
16.	F032403HCS	HHCS, #10-24 X 3/8 GR5 ZP	10
17.	F051808FWS	FWLS, 5/16-18 X 1 ZP	2
18.	F051812FWS	FWLS, 5/16-18 X 1-1/2 ZP	1
19.	F081305HCS	HHCS, 1/2-13 X 5/8 GR5 ZP	3
20.	M12ETLW	LOCKWASHER, M12, EXT TOOTH	3

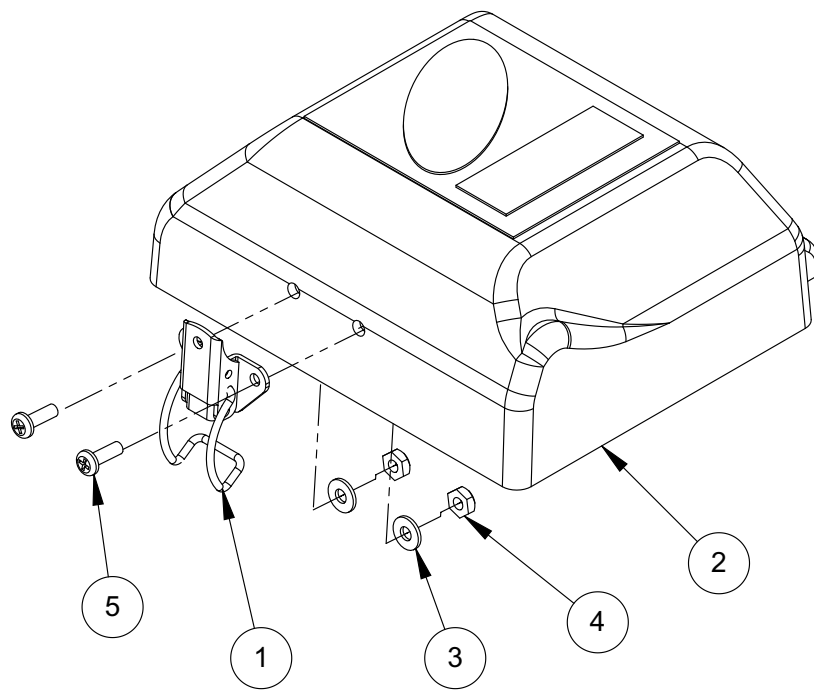

Cover Assembly

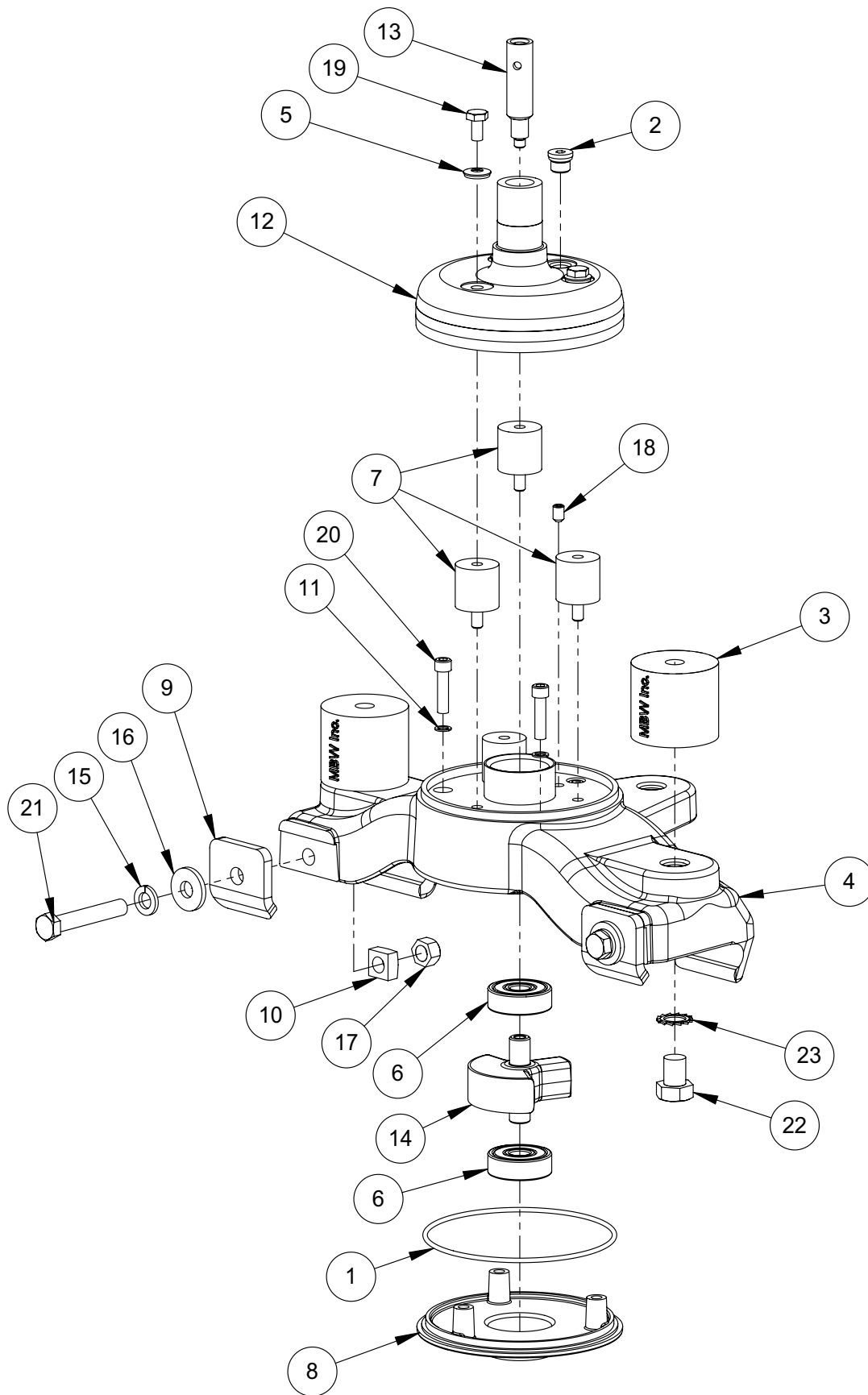

Exciter Assembly

ITEM	PART NO.	DESCRIPTION	QTY
1.	06237	O-RING, 4.33 ID X .103	1
2.	09618	FITTING, PARKER 4HP50N	1
3.	17170	SHOCKMOUNT, 2" OD X 1-3/4" LG	3
4.	17629	HOUSING, EXCITER	1
5.	17639	WASHER, SEALING	3
6.	17640	BEARING, BALL, SEALED 6301	2
7.	17643	SHOCKMOUNT, 1" OD X 1" LONG	4
8.	17645	COVER, EXCITER	1
9.	17725	PLATE, CLAMPING	2
10.	17736	NUT, SQUARE, CROWNED, 3/8-16	2
11.	17863	WASHER, FIBER, .25 X .38 X .03	3
12.	22133	MOTOR MOUNT	1
13.	22134	MOTOR ADAPTER	1
14.	22270	EXCITER, SCREEDEMON, M18	1
15.	F06LW	LOCKWASHER, 3/8 ZP	2
16.	F06SW	WASHER, 25/64 X 1 X 1/8 ZP	2
17.	F0616DLN	LOCKNUT, DEFORMED 3/8-16	2
18.	F042003SSS	SSS, 1/4-20 X 3/8"	1
19.	F042004HCS	HHCS, 1/4-20 X 1/2 GR5 ZP	3
20.	F042008SCS	SCS, 1/4-20 X 1/2 X 1	3
21.	F061618HCS	HHCS, 3/8-16 X 2-1/4 GR5 ZP	2
22.	F081305HCS	HHCS, 1/2-13 X 5/8 GR5 ZP	2
23.	M12ETLW	LOCKWASHER, M12 EXT. TOOTH	2
	22271	EXCITER ASM (includes all parts shown above)	

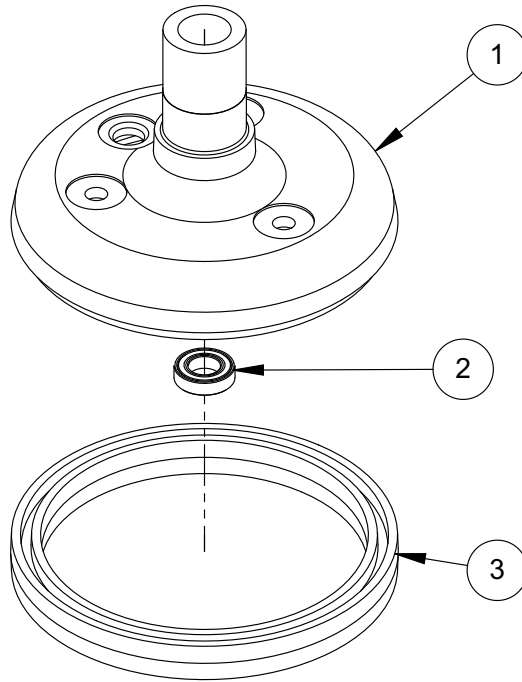

Motor Mount

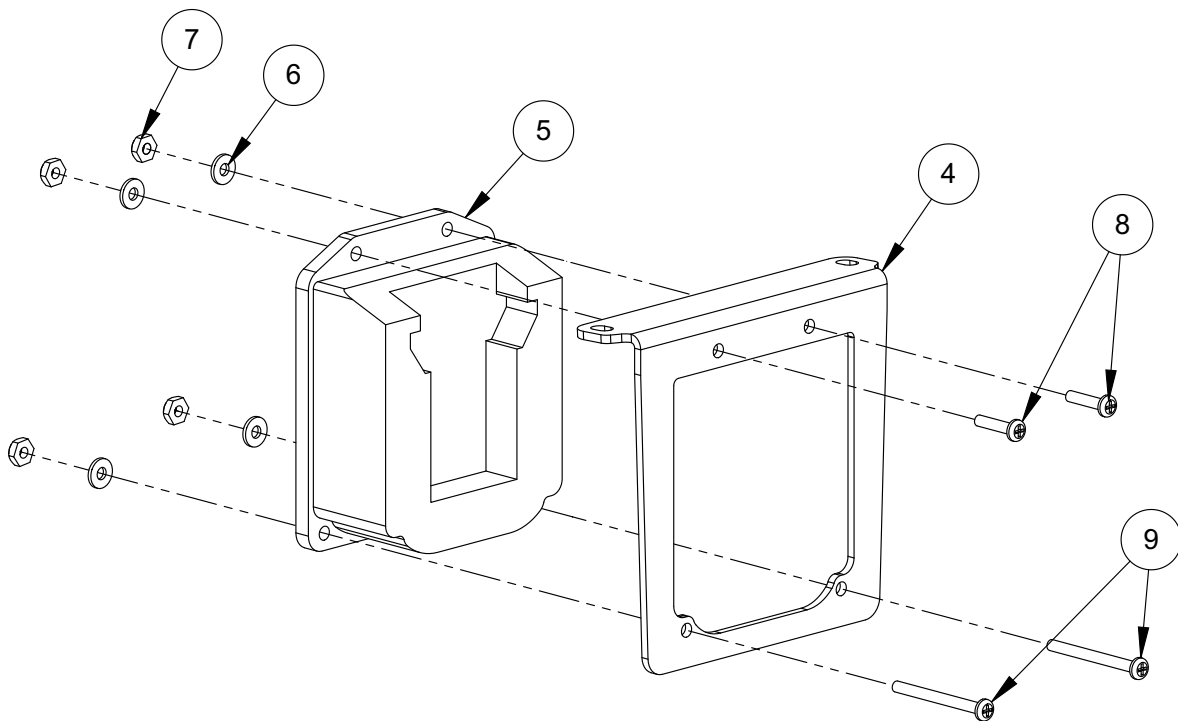

Battery Mount

ITEM	PART NO.	DESCRIPTION	QTY
1.	17634	FLANGE, ENGINE MOUNT	1
2.	17635	BEARING, BALL, SEALED	1
3.	1711	SEAL, RUBBER	1
4.	22139	BATTERY MOUNT	1
5.	22147	SOCKET, 18 VOLT BATTERY	1
6.	F01PW	WASHER, 5/32 X 3/8 X 18 GA	4
7.	F0132HN	NUT, HEX #6-32	4
8.	F013205PMS	PMS #6-32 X .625	2
9.	F013212PMS	PMS, #6-32 X 1.5	2
	22153 22154	BATTERY, MILWAUKEE, 12 AMP HR CHARGER, MILWAUKEE	

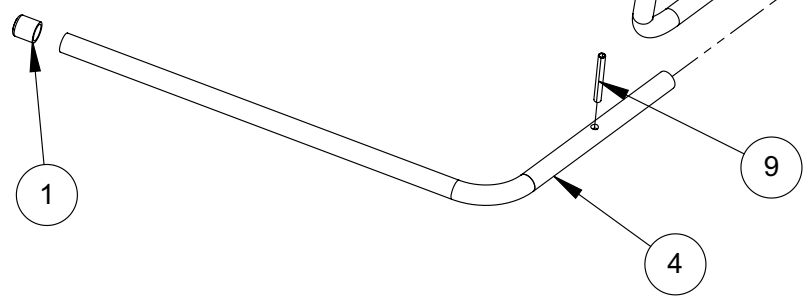
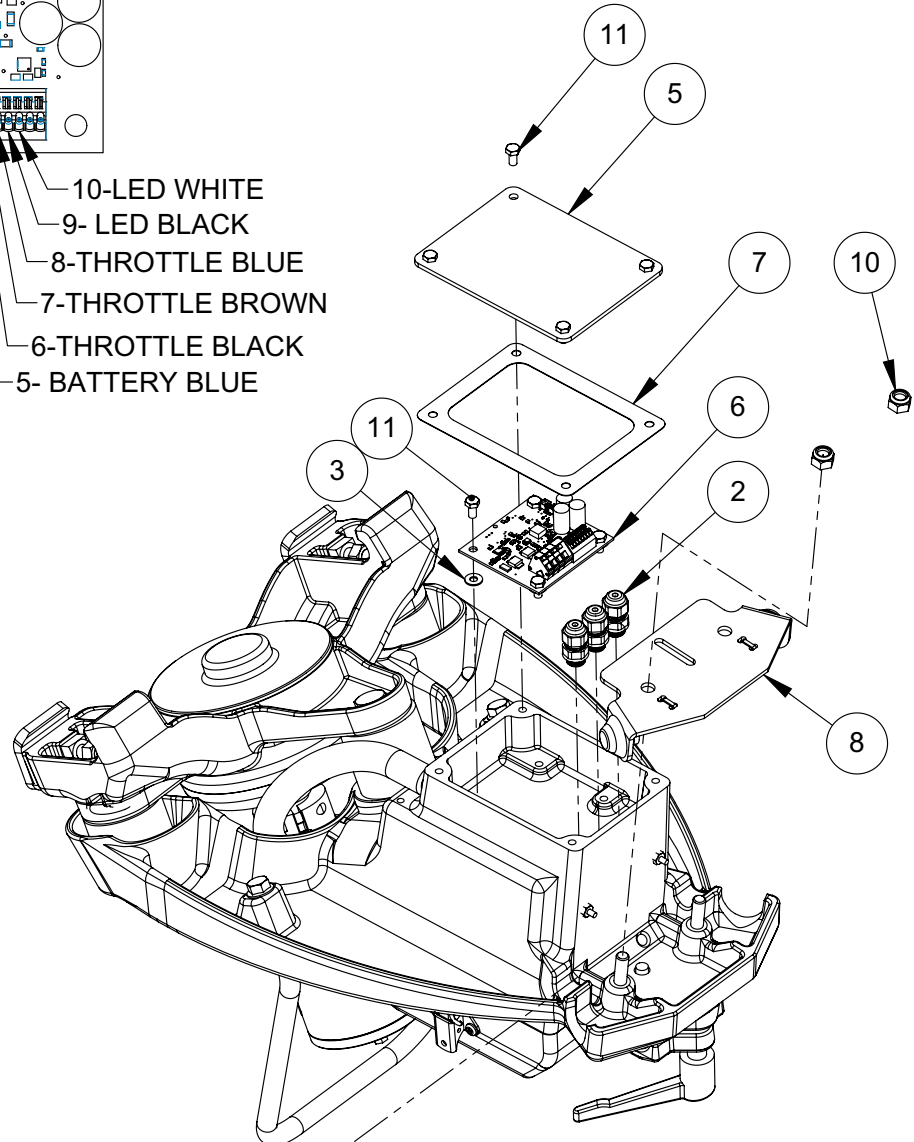
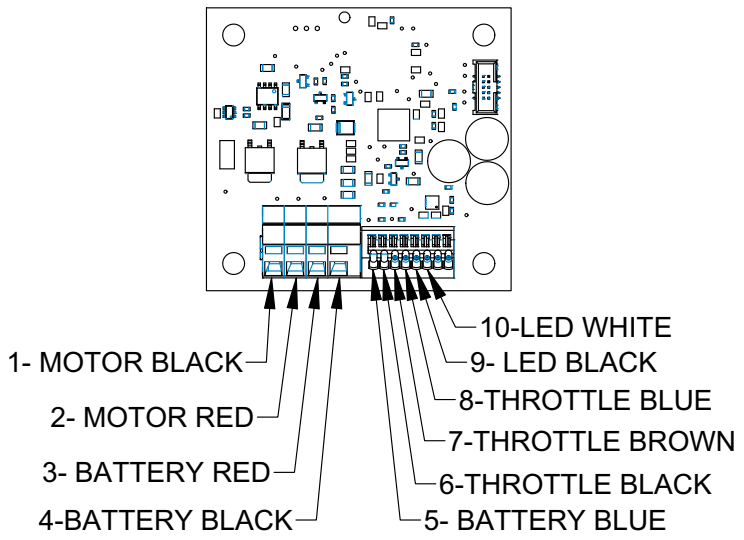

Electrical Assembly

ITEM	PART NO.	DESCRIPTION	QTY
1.	17662	CAP, VINYL, 7/16 ID	1
2.	22110	CORD GRIP	3
3.	22111	WASHER, PLASTIC, #10	4
4.	22122	SUPPORT LEG	1
5.	22123	COVER, ELECTRONICS	1
6.	22141	THROTTLE CONTROL BOARD	1
7.	22142	GASKET, ELECTRONICS	1
8.	22276	LIGHT ASM, 500M	1
9.	F0312SP	PIN, SPIRAL 3/16 X 1-1/2	1
10.	F0518ELN	LOCKNUT, 5/16-18 ZP	2
11.	F032403HCS	HHCS, #10-24 X 3/8	10

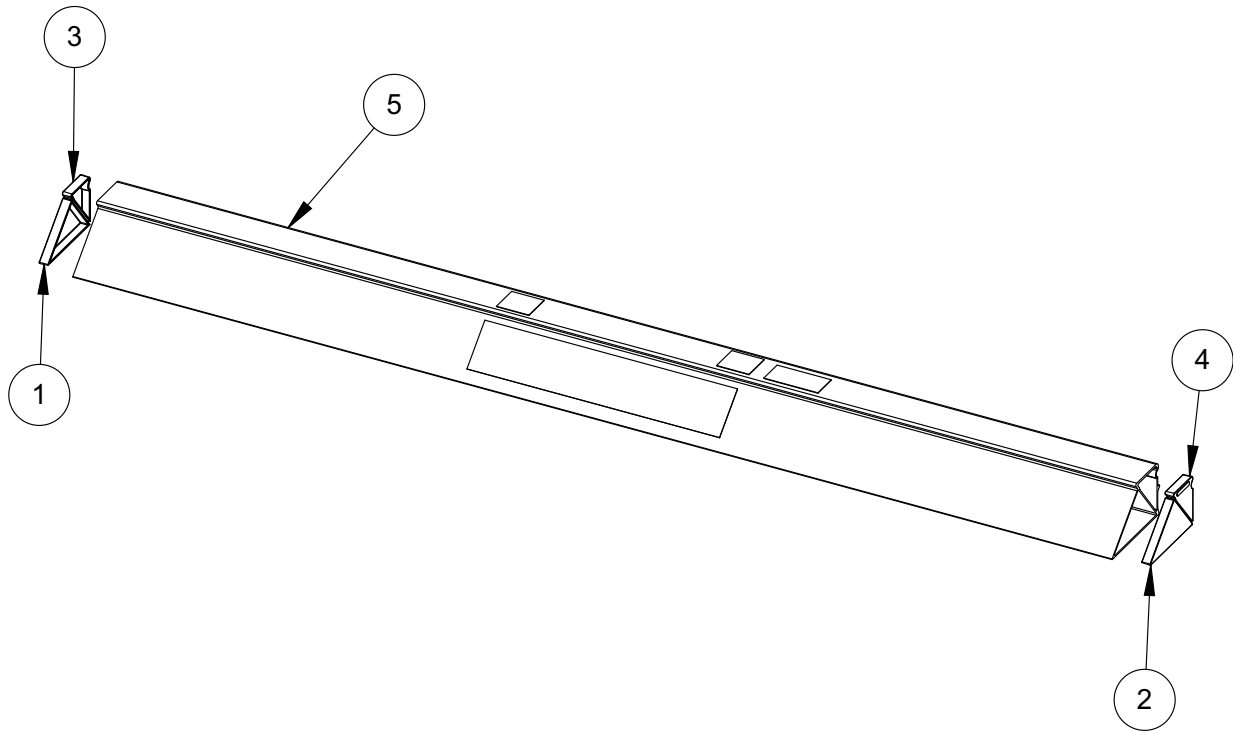

Screed Board Assembly

ITEM	PART NO.	DESCRIPTION	QTY
1.	17712	CAP, END, C SERIES, RF	1
2.	17714	CAP, END, C SERIES, LF	1
3.	18564	CAP, END, C SERIES, RR	1
4.	18565	CAP, END, C SERIES, LR	1
5.	17802	2' FLOAT	1
	17804	4' FLOAT	1
	17806	6' FLOAT	1
	17808	8' FLOAT	1
	17810	10' FLOAT	1
	17812	12' FLOAT	1
	17814	14' FLOAT	1
	17816	16' FLOAT	1
	17818*	18' FLOAT	1
	17820*	20' FLOAT	1
	17824*	24' FLOAT	1
	17831	KIT, CAPS (INCLUDES PARTS 1-4)	
		*Dual power heads required for 18' blades and above	

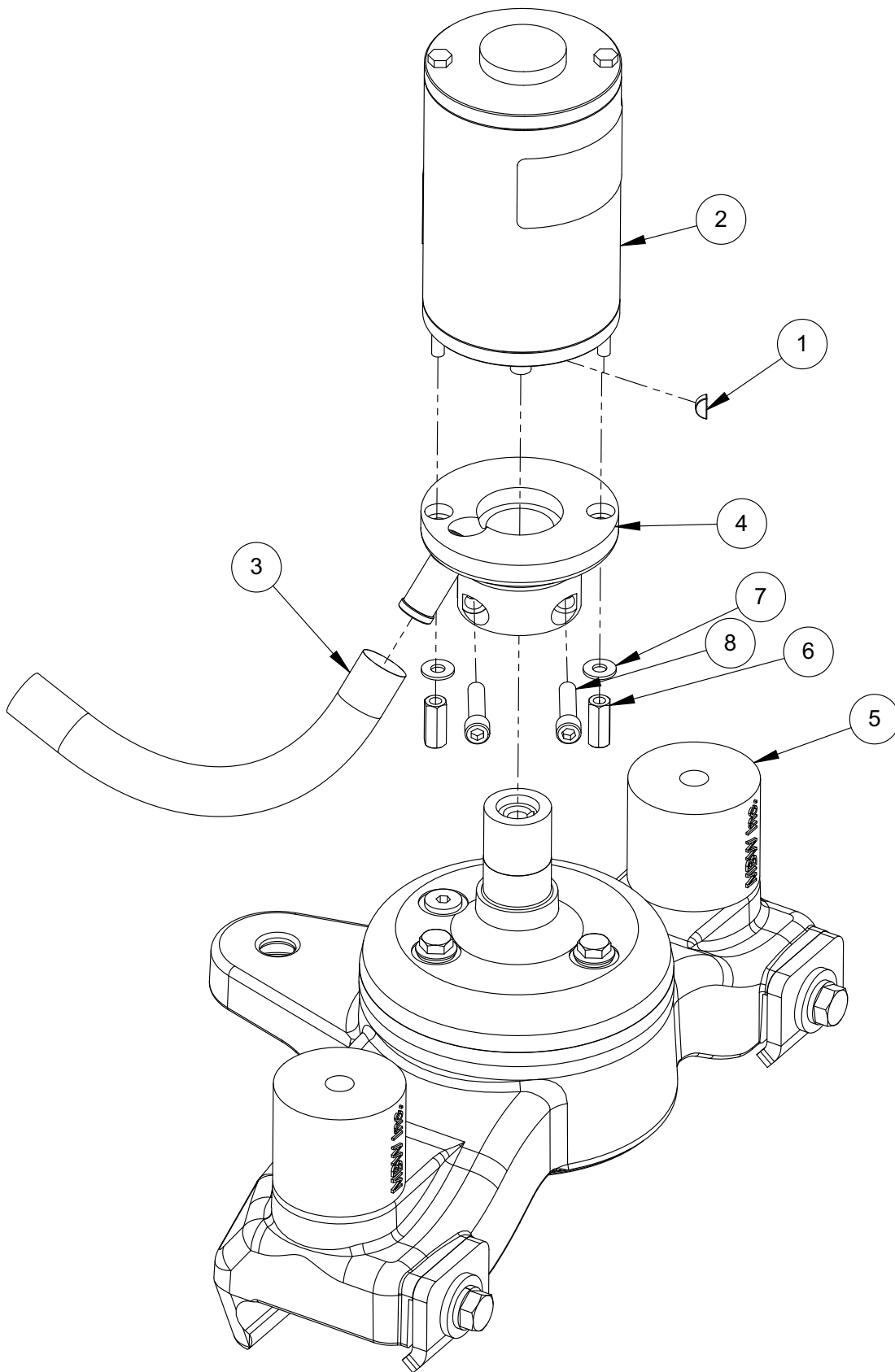

Motor Assembly

WARRANTY

WHAT DOES THIS WARRANTY COVER? MBW INC warrants each New Machine against defects in material and workmanship for a period of twelve (12) months. "New Machine" means a machine shipped directly from MBW or authorized MBW dealer to the end user. This warranty commences on the first day the machine is sold, assigned to a rental fleet, or otherwise put to first use.

MBW warrants each Demonstration Machine against defects in material and workmanship for a period of six (6) months. "Demonstration Machine" means a machine used by MBW or its agents for promotional purposes. This warranty commences on the first day the machine is sold, assigned to a rental fleet, or otherwise put to first use.

This warranty covers the labor cost for replacement or repair of parts, components, or equipment on New Machines or Demonstration Machines, and MBW shall pay labor costs at MBW's prevailing rate to affect the warranted repair or replacement. MBW reserves the right to adjust labor claims on a claim-by-claim basis.

This warranty covers the shipping cost of replacement parts, components, or equipment via common ground carriers from MBW to an authorized MBW dealer. Air freight is considered only in cases where ground transportation is not practical.

MAY THIS WARRANTY BE TRANSFERRED? This warranty is non-transferable and only applies to the original end user of a new machine or demonstration machine.

WHAT DOES THIS WARRANTY NOT COVER?

1. This warranty does not cover any Used Equipment. "Used Equipment" means any MBW machine or equipment that is not a New Machine or a Demonstration Machine. All Used Equipment is sold **AS IS/WHERE IS WITH ALL FAULTS**.

2. This warranty does not cover any New Machine, Demonstration Machine, or their equipment, parts, or components altered or modified in any way without MBW's prior written consent. This warranty does not cover the use of parts not specifically approved by MBW for use on MBW products. This warranty does not cover misuse, neglect, shipping damage, accidents, acts of God, the operation of any New Machine or Demonstration Machine in any way other than recommended by MBW in accordance with its specifications, or any other circumstances beyond MBW's control. This warranty does not cover any New Machine or Demonstration Machine repaired by anyone other than MBW factory branches or authorized MBW distributors.

3. This warranty does not cover, and MBW affirmatively disclaims, liability for any damage or injury resulting directly or indirectly from design, materials, or operation of a New Machine or Demonstration Machine or any other MBW product. MBW's liability with respect to any breach of warranty shall be limited to the provisions of this document and in no event shall exceed an amount equal to the purchase price of the New Machine or Demonstration Machine purchased from MBW.

4. This warranty does not cover engines, motors, and other assemblies or components produced by other manufacturers and used on a New Machine or Demonstration Machine, as said engines, motors, and other assemblies or components may have warranties provided by the manufacturer thereof. This warranty does not apply to consumable items, such as v-belts, filters, trowel and screed blades, seals, shock mounts, batteries, and the like, all of which are sold **AS IS/WHERE IS WITH ALL FAULTS**.

5. This warranty does not cover the cost of transportation and other expenses which may be connected with warranty service but not specifically mentioned herein.

6. This warranty does not cover any updates to any New Machine, Demonstration Machine, or any other MBW product. MBW reserves the right to improve or make product changes without incurring any obligation to update, refit, or install the same on New Machines or Demonstration Machines previously sold.

WHAT MUST YOU DO TO OBTAIN WARRANTY COVERAGE? Each New Machine or Demonstration Machine is accompanied by a Warranty Registration Card. You must sign, date, and return the Warranty Registration Card to the place of origin of the New Machine or Demonstration Machine, either to MBW, Inc. at P.O. Box 440, Slinger, Wisconsin 53086, MBW (UK), Ltd. at Units 2 & 3 Cochrane Street, Bolton BL3 6BN, United Kingdom or MBW FRANCE SARL at ZA D'Outreville, 5 Rue Jean Baptiste Neron, Bornel 60540 France, within ten (10) days after purchase, assignment to a rental fleet, or first use. This signed warranty card is the buyer's affirmation that he has read, understood, and accepted the warranty at the time of purchase. Failure to return the warranty card as specified herein renders the warranty null and void. In order to receive warranty coverage consideration, warranty claims must be submitted within thirty (30) days after the New Machine or Demonstration Machine fails. Warranty claims must be submitted to MBW, Inc., MBW (UK), Ltd. or MBW FRANCE SARL, and written authorization for the return of merchandise or parts under the warranty must be obtained before shipment to MBW.

WHAT WILL MBW DO? MBW's obligation under this warranty is limited to the replacement or repair of parts for a New Machine or Demonstration Machine at MBW factory branches or at authorized MBW distributors, and such replacement or repair is the exclusive remedy provided hereunder. Labor must be performed at an authorized MBW distributor. MBW reserves the right to inspect and render a final decision on each warranty case, and MBW's repair or replacement is solely within the discretion of MBW.

IT IS EXPRESSLY AGREED THAT THIS SHALL BE THE SOLE AND EXCLUSIVE REMEDY UNDER THIS WARRANTY. UNDER NO CIRCUMSTANCES SHALL MBW BE LIABLE FOR ANY COSTS, LOSS, EXPENSE, DAMAGES, SPECIAL DAMAGES, INCIDENTAL DAMAGES, OR PUNITIVE DAMAGES ARISING DIRECTLY OR INDIRECTLY FROM THE USE OF THE NEW MACHINE OR DEMONSTRATION MACHINE WHETHER BASED UPON WARRANTY, CONTRACT, NEGLIGENCE, STRICT LIABILITY, OR ANY OTHER LEGAL THEORY.

THE FOREGOING WARRANTY IS EXPRESSLY IN LIEU OF ALL OTHER WARRANTIES, EXPRESS OR IMPLIED, INCLUDING THE WARRANTIES OF MERCHANTABILITY, FITNESS FOR USE, AND FITNESS FOR A PARTICULAR PURPOSE, AND ALL OTHER OBLIGATIONS OR LIABILITY ON MBW'S PART. MBW NEITHER ASSUMES NOR AUTHORIZES ANY OTHER PERSON TO ASSUME ON BEHALF OF MBW ANY OTHER LIABILITY OR WARRANTY IN CONNECTION WITH THE SALE OR SERVICE OF ANY NEW MACHINE, DEMONSTRATION MACHINE, OR ANY OTHER MBW PRODUCT.

EXTENDED RAMMER WARRANTY - MODEL R222

This extended warranty commences on the last day of MBW's standard, one year, "limited warranty" and runs for an additional four years (48 months). This extended warranty is limited to part replacement and shipping costs of Rammer **bellows and non-metallic slide bearings only**. This extended warranty does not cover labor, down time, or any other cost beyond that of component replacement and freight. This extended warranty is subject to all limitations set forth in MBW's "limited warranty", above.