



WALKER

Operator's Manual

Safety, Assembly, Operating, and Maintenance Instructions



T27i

Please Read and Save These Instructions

For Safety, Read All Safety and Operation
Instructions Prior to Operating Machine

Beginning S/N: 159728
P/N 8000-38



Foreword

Thank you. . .for purchasing a Walker mower. Every effort has been made to provide you with the most reliable mower on the market, and we are sure you will be among our many satisfied customers. If for any reason this product does not perform to your expectations, please contact your local dealer. Every customer is important to us. Your satisfaction is our goal.

Please. . .read this manual thoroughly! This manual is to be used in conjunction with the engine manufacturer's manual for the specific engine on the mower model you have purchased. Before you operate your new mower, please read this entire manual. Some of the information is crucial for proper operation and maintenance of this mower - it will help protect your investment and ensure that the mower performs to your satisfaction. Some of the information is important to your safety and must be read and understood to help prevent possible injury to the operator or others. If anything in this manual is confusing or hard to understand, please contact your local authorized dealer or call our service department, at (970) 221-5614, for clarification before operating or servicing this mower.

This manual covers Model T27i with the Kohler Command Pro ECH749 (27.0 HP) Electronic Fuel Injection (EFI) gasoline engine.

All shields and guards must be in place for the proper and safe operation of this machine. Where they are shown removed in this manual, it is for illustration purposes only. **Do not operate this machine unless all shields and guards are in place.**

Specifications given are based on the latest information available at the time this manual was produced for a tractor with standard equipment. Optional equipment is available and may affect the standard specifications listed.

Walker Mfg. Co. is continually striving to improve the design and performance of its products. We reserve the right to make changes in specifications and design without thereby incurring any obligation relative to previously manufactured products.

Sincerely,
WALKER MANUFACTURING COMPANY

Bob Walker, Chairman

Table of Contents

General Information _____	1	Operating Instructions _____	28
HIGHLIGHTED INFORMATION _____	1	CONTROL IDENTIFICATION, LOCATION, AND FUNCTION _____	28
GLOSSARY _____	1	Operating Controls _____	28
IDENTIFYING NUMBER LOCATIONS _____	1	<i>Engine Throttle</i> _____	28
ENGINE SERIAL NUMBER LOCATION _____	2	<i>Forward Speed Control (FSC)</i> _____	29
SERVICING OF ENGINE AND DRIVETRAIN COMPONENTS _____	2	<i>Steering Levers</i> _____	29
Specifications _____	3	<i>Blade Clutch (PTO)</i> _____	29
ENGINE _____	3	<i>Front Body Latch Release</i> _____	29
ELECTRICAL SYSTEM _____	3	<i>Parking Brake</i> _____	31
TRANSMISSION _____	3	<i>Transmission Lockout Levers</i> _____	31
BLADE DRIVE _____	4	Instrument Panel _____	32
TIRE SIZE _____	4	<i>Hourmeter</i> _____	32
TIRE PRESSURE _____	4	<i>Voltmeter</i> _____	33
DRIVE BELTS _____	4	<i>Oil Pressure Warning Light/Horn</i> _____	33
SEAT _____	4	<i>Over Temperature Warning Light/Horn</i> _____	33
FRAME/BODY CONSTRUCTION _____	5	<i>Engine Service Light</i> _____	33
GHS SYSTEM (Optional) _____	5	<i>Ignition Switch</i> _____	34
MOWER DECK _____	5	<i>Light Switch (For Optional Lights)</i> _____	34
DIMENSIONS (Tractor and Mower) _____	6	<i>Warning Horn</i> _____	34
Component Identification _____	7	<i>Circuit Breaker</i> _____	34
Safety Instructions _____	10	STARTING THE ENGINE _____	34
BEFORE OPERATING _____	10	ADJUSTING GROUND _____	
OPERATING _____	12	SPEED AND STEERING _____	35
MAINTENANCE _____	14	ENGAGING THE BLADE DRIVE _____	37
SAFETY, CONTROL, AND INSTRUCTION DECALS _____	15	STOPPING THE MACHINE _____	38
Assembly Instructions _____	19	ADJUSTING CUTTING HEIGHT _____	39
SETUP INSTRUCTIONS _____	19	TRANSMISSION LOCKOUT _____	39
Tire Installation (Tractor) _____	19	RECOMMENDATIONS FOR MOWING _____	40
Battery Service _____	19	RECOMMENDATIONS FOR TILT-UP DECK OPERATION/TRANSPORT _____	42
<i>Wet Battery Service</i> _____	19	GRASS HANDLING SYSTEM (GHS) _____	43
<i>Dry Battery Service</i> _____	19	General Information _____	44
<i>Battery Charging</i> _____	20	Clogging Checklist _____	45
<i>Battery Installation</i> _____	21	Using the Tilt-Up Deck _____	46
Mower Deck Assembly _____	21	Using the GHS Catcher _____	46
<i>Deck Caster Wheels Installation</i> _____	21	<i>Powerfil</i> ® _____	46
<i>Deck Discharge Chute Installation</i> _____	21	<i>"Full" Signal Horn</i> _____	46
<i>Deck Discharge Deflector</i> _____		Cleaning the GHS Exhaust Screen _____	47
<i>Shield Installation</i> _____	22	Dumping the Catcher _____	47
<i>PTO Shaft Guard Installation</i> _____	22	<i>Tailgate Dumping</i> _____	47
<i>Tilt-Up Roller Wheel Installation</i> _____	22	<i>Using the Dump Bag</i> _____	48
Mower Deck Installation on Tractor _____	22	<i>Power Dump Option</i> _____	49
<i>Deck Installation</i> _____	22	<i>Hi-Dump</i> ® Option _____	49
<i>Deck Leveling</i> _____	25		
PREOPERATING CHECKLIST _____	26		

Table of Contents

Maintenance Instructions _____	53	Transmission Control Setting _____	71
MAINTENANCE SCHEDULE CHART _____	53	<i>Neutral-Park</i> _____	71
IMPORTANT TIPS FOR CARE		<i>Straight Ground Tracking</i> _____	71
OF THE KOHLER ENGINE _____	54	Blade Brake Action _____	71
Fuel System _____	54	PTO U-Joints _____	72
Starting/Stopping _____	54	Safety Switch System _____	72
Cooling System _____	54	Forward Speed Control Friction Lock _____	72
Air Cleaner System _____	54	REPLACING/REPAIRING _____	73
Oil _____	54	Drive Belts _____	73
LUBRICATION _____	55	<i>Engine PTO Drive Belt</i> _____	74
Engine Oil _____	55	<i>Jackshaft Drive Belt</i> _____	75
<i>Engine Break-In Oil</i> _____	55	<i>GHS Blower Drive Belt</i> _____	76
<i>Checking Engine Crankcase Oil Level</i> _____	55	<i>Hydrostatic Ground Drive Belt</i> _____	77
<i>Changing Engine Crankcase Oil/Oil Filter</i> _____	56	Fuel Filter _____	78
Mower Deck Gearbox Lubrication _____	56	Blade Overload Shear Bolts _____	78
DS52 or DS62 Mower Deck Lubrication _____	57	Mower Blades _____	79
Mower Deck Spindle Lubrication _____	57	ADJUSTMENTS _____	80
Tractor PTO Gearbox Lubrication _____	58	Transmission Control _____	80
<i>Checking Gearbox Oil Level</i> _____	58	<i>Steering Lever Position Adjustment</i> _____	80
<i>Changing Gearbox Oil</i> _____	58	<i>Set FSC Travel Limits (Stop)</i> _____	80
Gear Axle Lubrication _____	58	<i>Set Maximum Forward</i> _____	
Hydrostatic Transmission Fluid _____	59	<i>Travel Speed (Stop)</i> _____	81
<i>Checking Hydrostatic</i> _____		<i>Neutral Function Adjustment</i> _____	81
<i>Transmission Fluid Level</i> _____	59	<i>Straight Ground Travel Adjustment</i> _____	82
Grease Fitting and Oil Point Lubrication _____	59	Blade Clutch (PTO) _____	83
CLEANING _____	62	<i>Clutch Engagement/Belt Tension</i> _____	83
Engine Air Cleaner System _____	62	<i>Clutch Disengagement/Brake Action</i> _____	84
<i>Turbine Precleaner</i> _____	62	<i>Stop Block Eccentric Adjustment</i> _____	85
<i>Donaldson Radialseal™ Air Cleaner</i> _____	63	<i>Clutch Idler Pulley Travel Adjustment</i> _____	85
Engine Cooling System _____	65	<i>Blade Brake Band Adjustment</i> _____	86
<i>Cooling Air Intake Screen</i> _____	65	Forward Speed Control Friction Lock _____	87
<i>Cylinder Head Cooling Fins</i> _____	65	Steering Handles _____	88
Grass Buildup in Mower Deck Housing _____	66	Tilt-Up Deck Adjustable Stop _____	88
GHS Blower _____	66	GHS “Full” Signal Horn Adjustment _____	89
GHS Exhaust Screen _____	67	MAINTENANCE AND SERVICE	
Hydrostatic Transmission Cooling Fins _____	67	RECORD SHEET _____	90
CHECKING/SERVICING _____	68	Warranty _____	91
Security of Air Filtration Components _____	68		
Battery _____	68		
<i>Electrolyte Level</i> _____	68		
<i>Cleaning the Terminals</i> _____	69		
<i>Charging the Battery</i> _____	69		
Tire Pressure _____	69		
Wheel Bolt Torque _____	69		
Sharpen Mower Blades _____	69		
Drive Belts _____	70		
Mower Deck Gearbox Oil Seals _____	71		
Spark Plugs _____	71		
Ignition Wires _____	71		
Fuel Lines and Clamps _____	71		
Engine Starter _____	71		

General Information

HIGHLIGHTED INFORMATION

Walker Manufacturing recommends that any service requiring special training or tools be performed by an authorized Walker Mower dealer. There are several general practices to be aware of in the area of safety. Most accidents associated with the operation or maintenance of a Walker Mower are caused by disregarding basic safety precautions or specific warnings. Such accidents, in most cases, can be prevented by being aware of the dangers present.

Information of special importance has been highlighted in bold type in this manual. Refer to **Safety Instructions** for the meanings of **DANGER, WARNING, CAUTION, IMPORTANT, and NOTE.**

GLOSSARY

There are many terms that are either unique to this equipment or that are used as acronyms. The following terms and their definitions will help while using this manual:

- **DECK** is the mowing attachment mounted on the front of the tractor which includes the carrier frame, deck housing, belt or gear drive components, and cutter blades.
- **ELECTRONIC CONTROL UNIT (ECU)** controls engine functions such as spark timing, fuel/air ratio, etc.
- **FORWARD SPEED CONTROL (FSC)** controls the maximum forward speed of the tractor; functioning as a cruise control.
- **GRASS HANDLING SYSTEM (GHS®)** collects mowed material and deposits it in the catcher.
- **GRASS-PAK® SWITCH** is mounted on the grass delivery spout (in the catcher) and activates the "full" signal horn when the grass catcher is full.
- **GROUND DRIVE** refers to the dual hydrostatic transmissions which drive the main wheels.
- **HYDROSTATIC TRANSMISSION** transmits and controls power from the ground drive belt to the main drive wheel.

- **LEFT HAND (LH)** refers to the left-hand side of the tractor when the operator is seated facing forward in the tractor seat.
- **POWER TAKE-OFF (PTO)** transmits engine power to run the cutter blades and GHS blower.
- **POWERFIL®** spreads the mowed material throughout the interior of the grass catcher by an oscillating delivery spout.
- **RIGHT HAND (RH)** refers to the right-hand side of the tractor when the operator is seated facing forward in the tractor seat.
- **SIDE DISCHARGE (SD)** discharges mowed material from the right side of the mower deck.
- **STEERING LEVERS** steer the tractor by controlling the dual hydrostatic transmissions.
- **TRACTOR** is the prime mover, including the engine, drivetrain, operator seat, and controls to operate the mower.
- **TRANSMISSION LOCKOUT** releases the hydrostatic transmissions to permit freewheeling the tractor.

IDENTIFYING NUMBER LOCATIONS

The tractor serial number plate is affixed to the tractor body just below the left rear corner of the seat. The mower deck serial number plate is affixed alongside the angle iron framing on the LH side of the LH mower blade drive. Model and serial numbers are helpful when obtaining replacement parts and maintenance assistance. For ready reference, please record these numbers in the space provided.

Tractor Model No.	_____
Tractor Serial No.	_____
Deck Serial No.	_____
Engine Model No.	_____
Engine Serial No.	_____
Date of Purchase	_____

Fill In By Purchaser

General Information

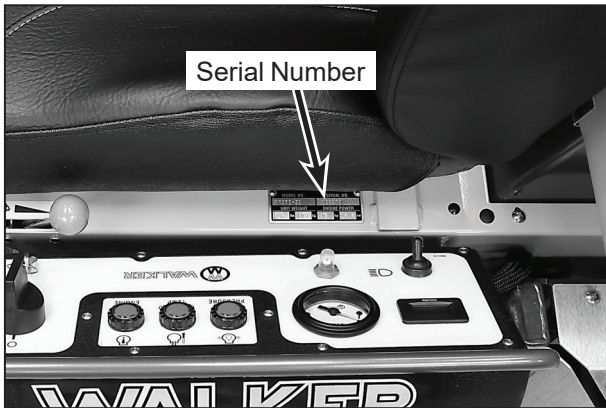

Tractor Serial Number Location

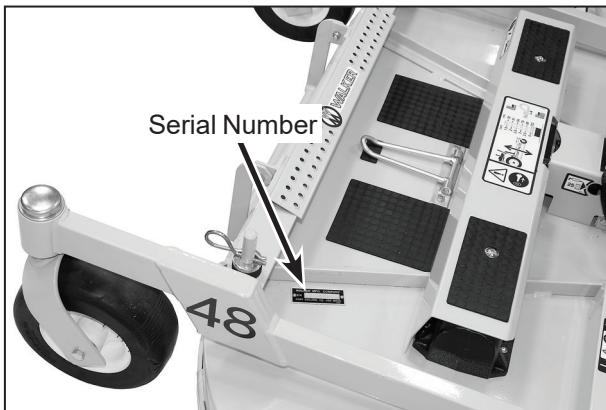

Mower Deck Serial Number Location

ENGINE SERIAL NUMBER LOCATION

Refer to the engine manual that accompanies this manual or photo below for the location of the engine serial number.

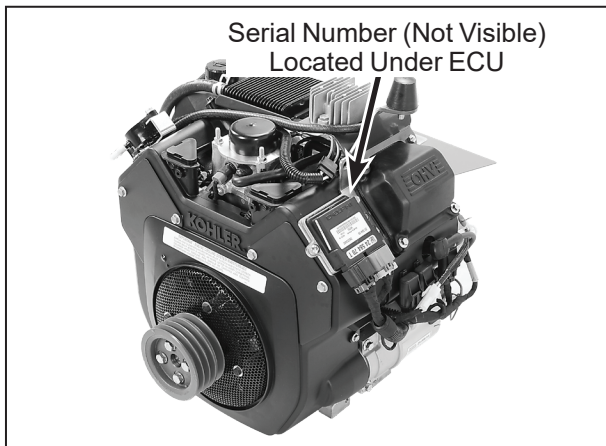

Engine Serial Number Location

SERVICING OF ENGINE AND DRIVETRAIN COMPONENTS

The detailed servicing and repair of the engine, hydrostatic transmission, and gearboxes are not covered in this manual. Only routine maintenance and general service instructions are provided. For the service of these components during the limited warranty period, it is important to find a local, authorized servicing agent of the component manufacturer. **Any unauthorized work done** on these components during the warranty period **may void the warranty**. If you have any difficulty finding an authorized outlet or obtaining warranty service, please contact our Service Department for assistance:

Walker Manufacturing Company

5925 E. Harmony Road
Fort Collins, CO 80528
1-970-221-5614
www.walker.com

Service manuals are available for each of these components from their respective manufacturers as follows:

Kohler Engines

Kohler Company

Kohler, WI 53044
800-544-2444
www.kohlerengines.com

Hydrostatic
Transmissions

Eaton Fluid Power Group Hydraulics Business USA

14615 Lone Oak Road
Eden Prairie, MN 55344 USA
952-937-9800
www.eaton.com/hydraulics

Gearboxes (Deck)

Peerless Gear

1555 South Jackson St.
Salem, IN 47167 USA
866-536-8310
www.peerlessgear.com

Specifications

MODEL	T27i
ENGINE	
Manufacturer/Model	Kohler Command Pro® ECH749, 2 Cyl., Gasoline (Air-Cooled), Electronic Fuel Injection (EFI)
Displacement cu. in. (cc)	45.6 (747)
Max. Power HP (kW)	27.0 (20.1) @ 3600 RPM
Governed RPM	3600
Max. Torque lb·ft (N·m)	40 (54)
Idle RPM	1200
Spark Plug Type	Champion® RC12YC
Spark Plug Gap in. (mm)	.030 (0.76)
Crankcase Capacity qt (L)	2.0 (1.9)
Crankcase Lubricant (From Factory)	300 Hour, Kohler PRO® Synthetic 10W-50 Kohler P/N 25 357 72-S
Oil Filter (From Factory)	300 Hour, Kohler PRO® Filter P/N 25 050 53-S
Conventional Crankcase Lubricant (Alternative Option)	100 Hour, API SJ or Higher Grade Oil Only with 10W-30 Viscosity Above 0° F (-18° C), or 5W-30 Viscosity Below 32° F (0° C)
Oil Filter (Alternative Option)	200 Hour, Kohler Filter P/N 12-050-01-S
Cooling System	Air-Cooled
Fuel Tank Capacity gal (L)	4.7 (17.8)
Fuel	Regular Grade Unleaded Gasoline (87 Octane Minimum, 10% Ethanol Maximum)
Air Cleaner	Remote Mounted Donaldson Radialseal™ (Walker P/N 5090-1 Primary/5090-3 Safety Filter)
ELECTRICAL SYSTEM	
Battery	12 Volt, 35AH, 340 CCA
Charging System	Flywheel Alternator
Charging Output	25 Amp DC (Regulated)
System Polarity	Negative Ground
Ignition	Electronic Capacitive Discharge
Starter	12 Volt Electric Ring-Gear Type, Solenoid Shift
Interlock Switches	Ignition Lockout by Seat Switch, Transmission Neutral, Blade Clutch, and Parking Brake
Circuit Breaker	Manual Reset (7A) Auto Reset (30A)
TRANSMISSION	
Manufacturer/Model	Dual Hydrostatic, Eaton Model 7, Each Wheel Independently Driven
Steering	Hand Lever Control / Individual Wheel
Forward Speed Control	Precision Friction Lock Lever, Cruise Control, with Neutral-Park Position

Specifications

MODEL	T27i
TRANSMISSION (continued)	
Service Brake	Dynamic Braking through Hydrostatic Transmission(s)
Parking Brake	Mechanical Pin Lock in Transmission Gear
Neutral	Transmission Release by Manual Dump Valve
Final Drive	Gear Drive Axle
Transmission Fluid	
Factory Service	Mobil SHC™ 630
Transmission Oil Capacity fl oz (L)	19 (0.56)
Transmission Cooling	Cooling Fan Mounted on Drive Pulley
Ground Travel Speed	
Forward MPH (km/h)	0-7 (0-11) Infinitely Variable
Reverse MPH (km/h)	0-5 (0-8) Infinitely Variable
BLADE DRIVE	
PTO Shaft	Quick Disconnect Splined Shaft with Two (2) High-Speed U-Joints
Blade Drive Clutch and Brake	Manual Belt Tightener Clutch and Band Brake [Stops Blades within Five (5) Seconds of Disengagement]
TIRE SIZE	
Deck Caster	8 x 3.00-4 (Semi-Pneumatic, All Decks Except DS52, DS62, DS74) 8 x 3.00-4 Pneumatic 4-Ply (Optional), All Decks Except DS52, DS62, DS74 11 x 4.00-5 (Pneumatic 6-Ply, DS52, DS62, DS74 Only)
Drive	18 x 9.50-8 (Pneumatic 4-Ply, Standard) 18 x 10.50-10 (Pneumatic 4-Ply, Optional Low-Profile)
Tailwheel	13 x 4.50-6 (Pneumatic 6-Ply, Standard Dual) 13 x 8.00-6 (Pneumatic 4-Ply, Optional Single)
TIRE PRESSURE PSI (KPA)	
Deck Caster Wheel*	20 (137)
Drive	15 (103)
Tailwheel	20 (137)
* If equipped with optional pneumatic tires	
DRIVE BELTS	
Engine PTO	Walker P/N 8230
Jackshaft Drive	Walker P/N 6250-1
Ground Drive, Micro-V	Walker P/N 7248
Blower (GHS Model)	Walker P/N 7234-2
SEAT	Built-up Seat with Steel Frame, Extra Thick Foam Cushions and Bolsters, and Removable/Replaceable Nylon Backed Vinyl Covers

Specifications

MODEL	T27i
FRAME/BODY CONSTRUCTION	
Frame	All Welded Unitized Steel Chassis
Body	14 Gauge Steel
Deck	11 Gauge Steel
GHS Catcher and Chutes	Molded Cross-Linked Polyethylene (High Impact Material, UV Stabilized)
GHS SYSTEM (Optional)	
Blower	10.5 in. Diameter, Three-Blade Paddle Wheel
Blower Brake	Band Brake [Works in Combination with PTO Clutch, Stops Blower within Five (5) Seconds of PTO Disengagement]
Max. Blower RPM	4000
Hi-Dump Option	200 (91)
Max. Lift Capacity lb (kg)	
Grass Catcher Capacity gal / bu / L	93 / 10 / 352
Full Signal (Grass-Pak® Switch)	Oscillating Vane Switch Mounted on Grass Delivery Spout Triggers Horn Signal
Powerfil®	Oscillating Delivery Spout Driven by 12 Volt Electric Gearmotor Spreads Material throughout Interior of Catcher @ 35 Cycles/Min
MOWER DECK	
Recommended Cut Width	
Collection	42 to 52 in. (107 to 132 cm)
Side Discharge	42 to 74 in. (107 to 188 cm)
Mulch	42 to 52 in. (107 to 132 cm)
Cutting Height	1.5 to 4 in. (4 to 10 cm) or 1.5 to 4.5 in. (4 to 11.5 cm) (DS52 & DS62 Belt Driven Decks Only)
Deck Suspension	Independent Torsion-Flex Frame with Caster Wheels and Counterweight Springs

Specifications

MODEL T27i

DIMENSIONS (Tractor and Mower)

Length in. (cm)

Tractor Only	64.25 (164)
Tractor Wheel Base	41 (104)
Tractor with Tilted Deck (Approximate)	77 (196)
Tractor with 48" Collection Deck (DC48-1)	93 (236)

Width in. (cm)

Tractor Only (Outside Tire)	39 (99)
Tractor with 48" Collection Deck (DC48-1)	49.25 (125)
Tread Width	30 (77)

Height in. (cm)

Tractor	50 (127)
---------	----------

Weight lb (kg)

Tractor Only	787 (357)
Tractor with 48" Collection Deck (DC48-1)	1006 (457)

NOTE: The manufacturer reserves the right to make changes in specifications shown herein at any time without notice or obligation. The specifications listed are for a standard configuration tractor, and may change with the addition of optional equipment.

Component Identification

NOTE: Control Identification shown in **Operating Instructions** section.

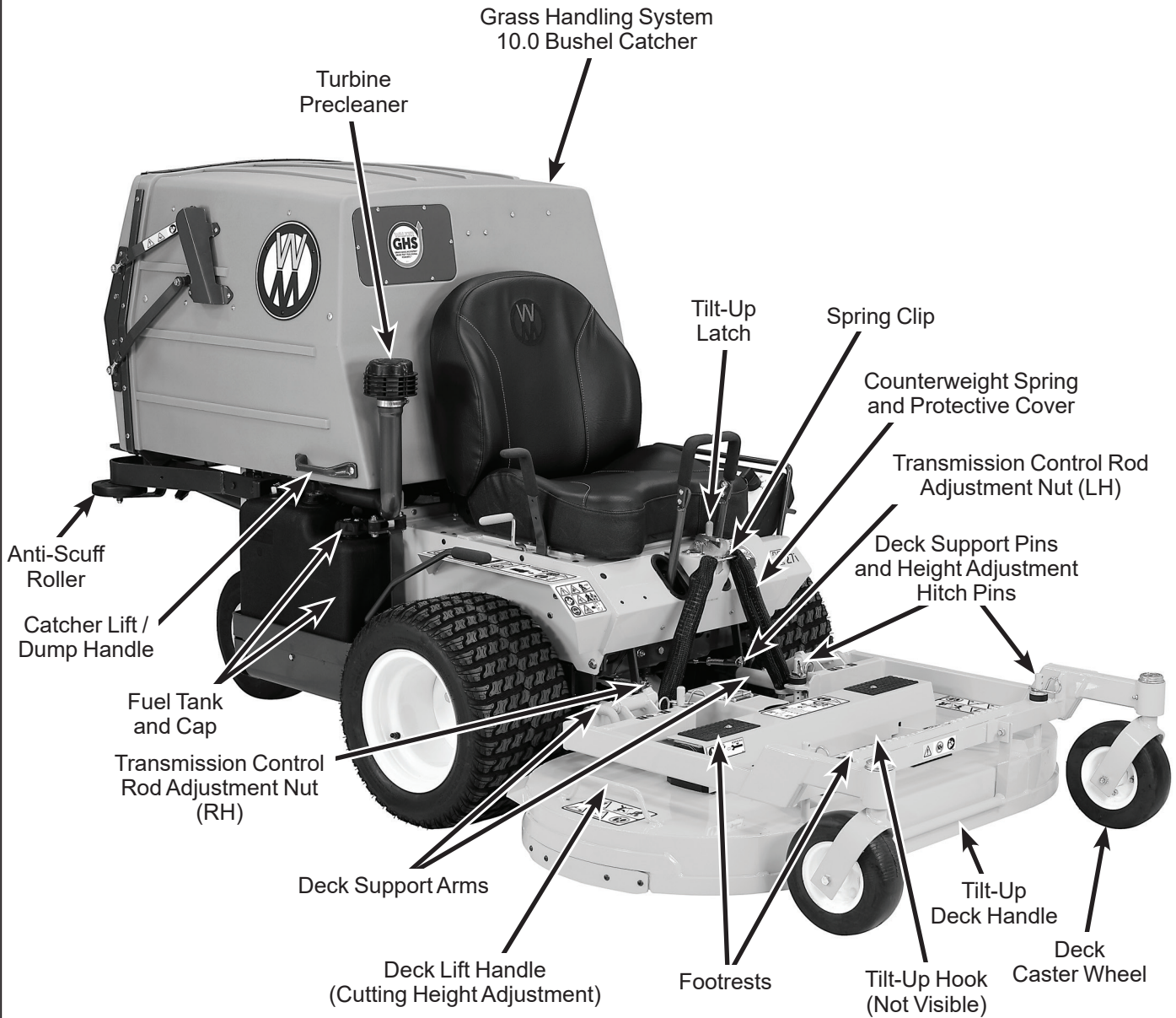

Front View and Right Side View

Component Identification

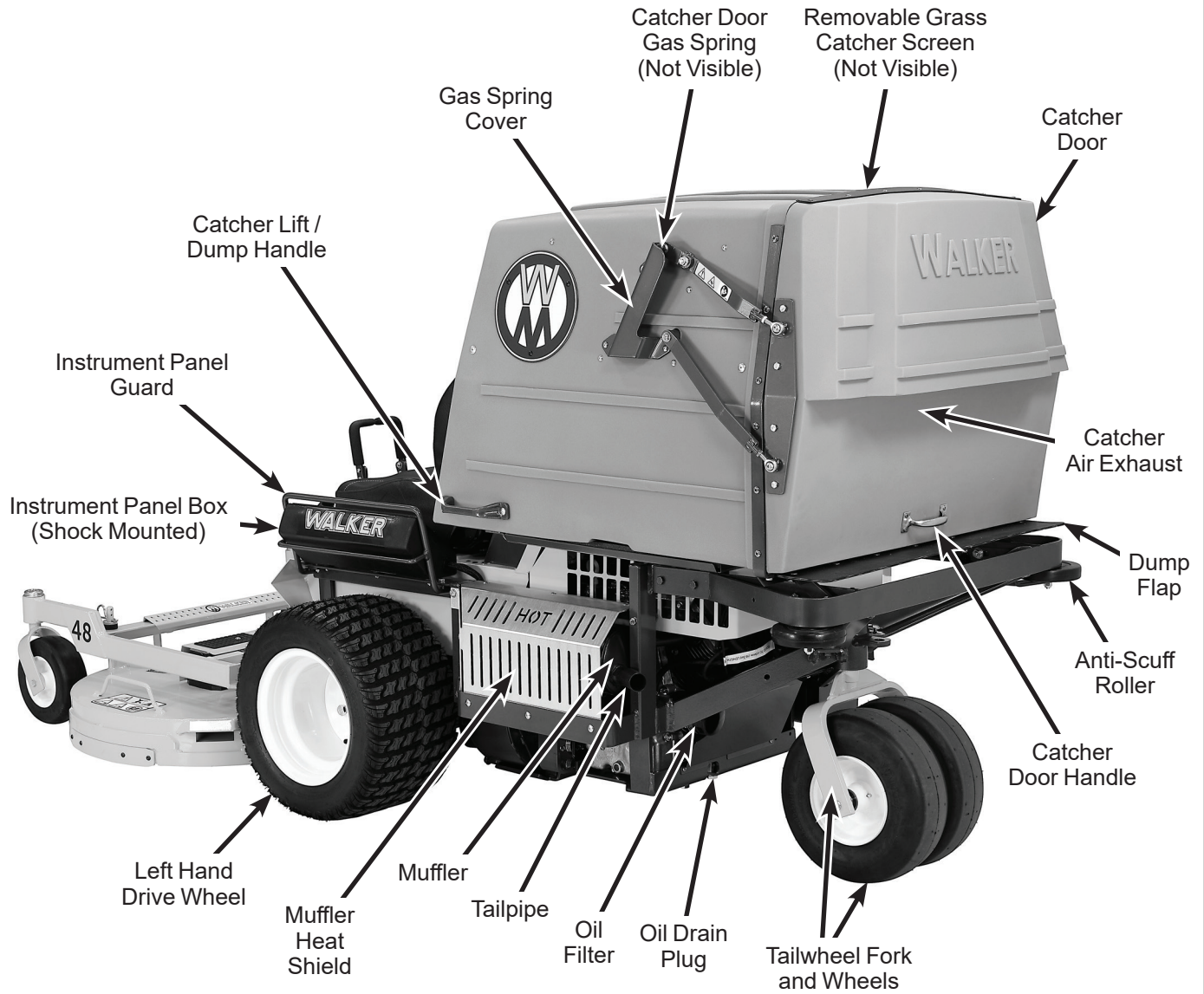

Rear View and Left Side View

Component Identification

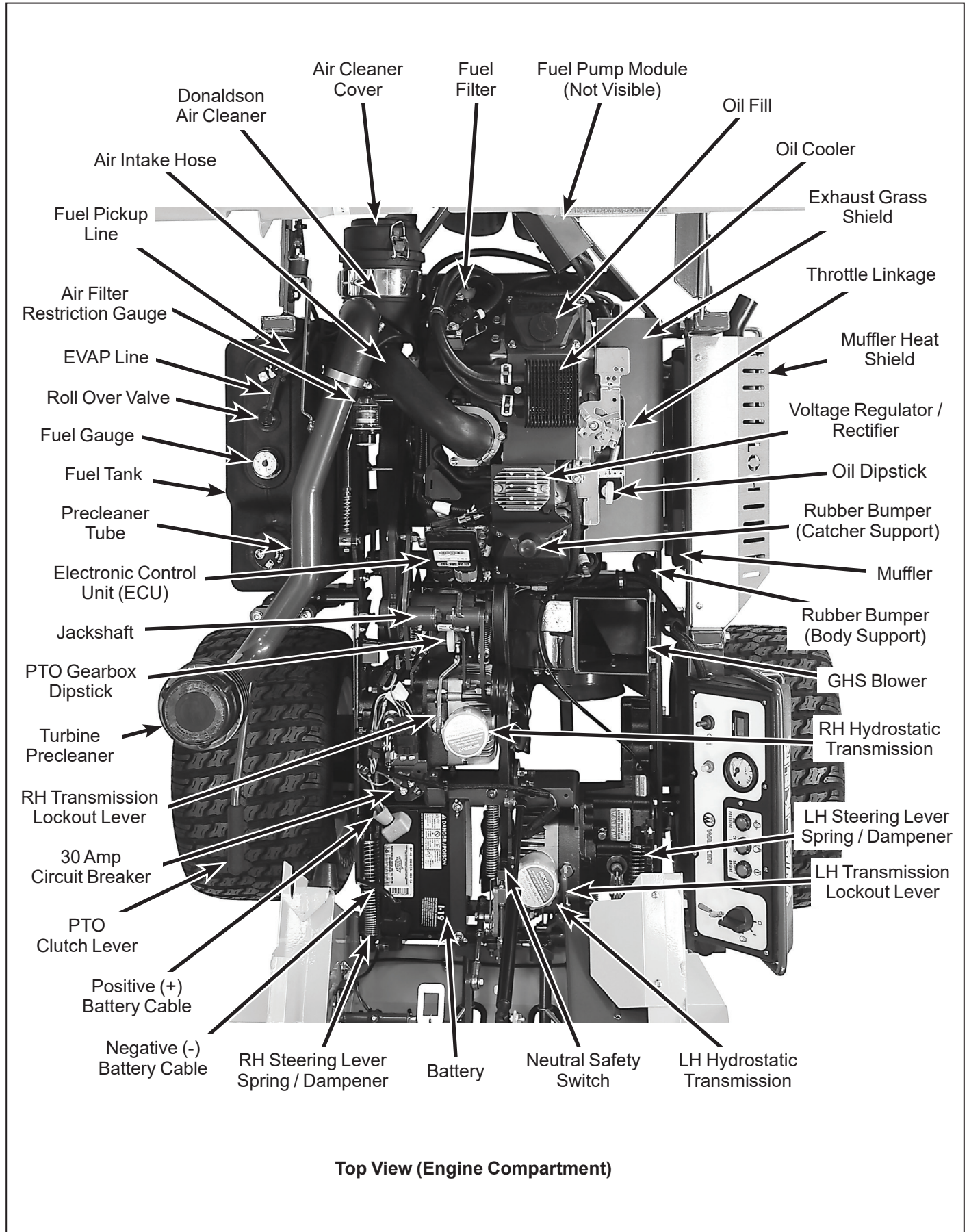

Safety Instructions - Before Operating

Pay particular attention to any information labeled **DANGER, WARNING, CAUTION, IMPORTANT,** and **NOTE** in this manual.

When you see the Safety Alert Symbol (), read, understand, and follow the instructions. Failure to comply with safety instructions may result in personal injury.

The seriousness or degree of importance of each type of information is defined as follows:

DANGER

An **IMMEDIATE** hazard that **WILL** result in **severe personal injury or DEATH**, if **warning is ignored and proper safety precautions are not taken**.

WARNING

A **POTENTIAL** hazard that **COULD** result in **severe personal injury or DEATH**, if **warning is ignored and proper safety precautions are not taken**.

CAUTION

Possible hazards or unsafe practices that **MAY** result in **MODERATE** personal injury or property damage, or machine damage, if **warning is ignored and proper safety precautions are not taken**.

IMPORTANT: Identifies mechanical information demanding special attention, since it deals with the possibility of damaging a part or parts of the machine.

NOTE: Identifies information worthy of special attention.

Walker Manufacturing cannot predict every potentially dangerous situation. Therefore, items labeled as such in this manual do not cover all conceivable situations. Any person using procedures, tools, or control techniques not recommended by Walker Manufacturing must take full responsibility for safety.

The Walker Rider Lawnmower has been designed with many safety features to protect the operator from personal harm or injury. However, it is necessary for the operator to use safe operating procedures at all times. **Failure to follow safety instructions contained in this manual may result in personal injury or damage to equipment or property.**

If you have any questions concerning setup, operation, maintenance, or safety, please contact your authorized Walker Mower Dealer or call Walker Manufacturing Company at (970) 221-5614.

BEFORE OPERATING

1. **Read and understand the contents of this Operator's Manual before starting and operating the machine.** Become thoroughly familiar with all machine controls and how to stop the machine and disengage the controls quickly. Replacement Operator's Manuals are available by sending the Model and Serial Number to:

Walker Manufacturing Company
5925 East Harmony Road
Fort Collins, CO 80528

2. **Never allow children to operate rider mower.** Do not allow adults to operate without proper instruction.
3. **Clear the area to be mowed of any foreign objects** which may be picked up and thrown by cutter blades. Pick up all sticks, stones, wire, and any other debris.
4. Keep everyone, especially children and pets, a safe distance away from the area being mowed. **Do not mow with bystanders in the area.**
5. Do not operate the machine barefoot or wearing sandals, sneakers, tennis shoes, or similar lightweight footwear. **Wear substantial protective footwear.**

Safety Instructions - Before Operating

6. Do not wear loose fitting clothing that could get caught in moving parts. Do not operate this machine while wearing shorts; **always wear adequate protective clothing**, including long pants. Wearing safety glasses, safety shoes, and a helmet is advisable and required by some local ordinances and insurance regulations.
7. Prolonged exposure to loud noise can cause impairment or loss of hearing. **Operator hearing protection is recommended**; particularly for continuous operation of the GHS Model due to blower noise level. Wear a suitable hearing protective device, such as earmuffs or earplugs.
8. **Keep all protective shields and safety devices in place.** If a protective shield, safety device, or decal is damaged, unusable, or missing, repair or replace it **before** operating the machine.
9. **Be sure interlock switches are functioning correctly**, so the engine cannot be started unless the Forward Speed Control lever is in the **NEUTRAL-PARK** position, the PTO clutch is in the **DISENGAGED** position, and the Parking Brake is in the **ENGAGED** position. Also, the engine should stop if the operator lifts off the seat with any one or more of these controls in the operating position: (1) Forward Speed Control (FSC) out of **NEUTRAL-PARK**, (2) PTO Clutch **ENGAGED**, or (3) Parking Brake **DIS-ENGAGED**.

NOTE: There is a 1/2 second time delay function on the seat switch to avoid engine power interruption when driving over bumps.
10. **Handle gasoline with care.** Gasoline is highly flammable and its vapors are explosive:
 - a. Use an approved fuel container.
 - b. Never add fuel to a running engine or hot engine (allow hot engine to cool several minutes).
 - c. Keep matches, cigarettes, cigars, pipes, open flames, or sparks away from the fuel tank and fuel container.
 - d. Always fill the fuel tank outdoors using care. Fill to about one inch from the top of the tank. Use a funnel or spout to prevent spilling.
 - e. Replace the machine fuel cap and container cap securely and clean up any spilled fuel before starting the engine.
11. **Never attempt to make any adjustments while the engine is running**, except where specifically instructed to do so.
12. The electrical system battery contains sulfuric acid. Avoid any contact with skin, eyes, and clothing. Keep the battery and acid out of reach of children.



WARNING

This product can expose you to chemicals including Di-(2-ethylhexyl) phthalate which is known to the State of California to cause cancer, and Di-(2-ethylhexyl) phthalate, which is known to the State of California to cause birth defects or other reproductive harm. For more information go to www.P65Warnings.ca.gov.

Safety Instructions - Operating

1. **Operate the mower only in daylight** or in good artificial light with good visibility of the area being mowed.
2. Sit on the seat when starting the engine and operating the machine. Keep feet on the deck footrests at all times when the tractor is moving and/or mower blades are operating. **Never operate the tractor without a deck or implement installed.**
3. For a beginning operator, **learn to steer (maneuver) the tractor with a slow engine speed before attempting any mowing operation.** Be aware that, with the front mounted mower configuration, the back of the tractor swings to the outside during turns.



DANGER

Do not mow around overhanging tree branches or bushes at the same height as the operator's torso and head where inadvertent contact may cause injury.

4. Remember, for an emergency stop, the forward motion of the tractor can always be stopped by pulling the Forward Speed Control (FSC) into the **NEUTRAL-PARK** position.
5. In case either of the transmission drive belts break during operation, and if the machine is on a slope, the machine will freewheel down the slope. **To maintain control**, immediately (1) Release the steering levers and simultaneously (2) Move the FSC to the **NEUTRAL-PARK** position. When the machine is stopped or moving slowly, engage the parking brake.
NOTE: The emergency stop procedure is exactly the same procedure as used to normally stop and park this machine.
6. Disengage the blade clutch, put the FSC in the **NEUTRAL-PARK** position and engage the Parking Brake before starting the engine (an ignition interlock switch normally prevents starting of the machine if these controls are in the **OPERATING** position).

7. **Do not operate machine if the operator presence safety switch system is not working.** Verify proper operation by having the operator lift off the seat with the engine running and moving three controls, one at a time; (1) Move the FSC lever out of the **NEUTRAL-PARK** position, (2) Engage the PTO Clutch, and (3) Disengage the Parking Brake. Moving any of these controls should stop the engine after a 1/2 second delay.
8. **Do not run the engine in a confined area without adequate ventilation.** Exhaust fumes are hazardous and can be deadly.
9. **Do not carry passengers** - maximum seating capacity is one (1) person.
10. Watch for holes, rocks, and roots in the terrain and for other hidden hazards. When mowing tall grass, mow higher than desired to expose any hidden obstacles. Then, clean the area and mow to the desired height.
11. **Avoid sudden starts or stops.** Before backing the machine up, look to the rear to be sure no one is behind the machine. Watch carefully for traffic when crossing or working near roadways.
12. When moving forward, **do not** suddenly put the tractor in reverse by rapidly pulling on the steering levers, especially when going downhill, as this can lift the tractor tail wheel off the ground and set up a bucking motion due to operator overcontrol. If bucking does occur, immediately stop the bucking action by pulling the Forward Speed Control (FSC) lever into the **NEUTRAL-PARK** position.
13. Disengage the blade drive when transporting the machine across drives, sidewalks, etc. **Never raise the mower deck while blades are rotating.**



DANGER

Do not mow or dump grass within 5 feet (1.5 meters) of an embankment or retaining wall with drop off.

Safety Instructions - Operating

14. **The maximum recommended slope operating angle is 15 degrees or 27% grade.** When operating the machine on a slope, reduce speed and use caution to start, stop, and maneuver. To prevent tipping or loss of control of the machine, avoid sharp turns or sudden changes in direction. **Do not operate the machine on a slope greater than 15 degrees.**
15. **Never adjust cutting height with the engine running.** Before adjusting cutting height or servicing, disengage the blade clutch (PTO), engage parking brake, stop the engine, and remove the ignition key. Wait for all movement to stop before getting off the seat.

NOTE: A blade/blower brake should normally stop drive line rotation within five (5) seconds of disengaging the PTO clutch.
16. For side discharge mower decks, **do not operate with the grass deflector shield removed.** Keep the deflector in the lowest possible position.
17. When using the tilt-up deck, **observe the following:**
 - a. Do not move tractor with deck in tilt-up position.
 - b. Never tilt body forward with deck in tilt-up position.
18. For GHS equipped models, **do not operate the machine with the grass catcher in the DUMP position or with the back door OPEN.** Dangerous projectiles may be thrown out of the discharge chute or the back of the grass catcher.
19. For GHS equipped models, **use care when closing the grass catcher door.** Keep fingers and hands away from the hinge and pinch points when the door is being closed. Also, keep fingers and hands clear of the door frame. The door may slam shut with considerable force.
20. **In case of a clogged or plugged mower deck or GHS catching system:**
 - a. Disengage the blade clutch (PTO), engage the parking brake, and turn the engine off before leaving the seat.
 - b. **LOOK** to make sure blade drive shaft and blower drive pulley movement has stopped before trying to unclog the system.
 - c. Disconnect the spark plug wires.
 - d. Never place hands under the deck or in the GHS blower - use a stick or similar tool to remove clogged material.
21. If the cutting blades strike a solid object or the machine begins to vibrate abnormally, **immediately disengage the blade clutch (PTO), engage the parking brake, stop the engine, and wait for all moving parts to stop.** To prevent accidental starting, disconnect the spark plug wires. Thoroughly inspect the mower and repair any damage before restarting the engine and operating the mower. Make sure cutter blades are in good condition and blade nuts are torqued to 60 lb·ft (81 N·m) for gear driven decks, and blade bolts torqued to 70 lb·ft (95 N·m) for belt driven decks.
22. **Do not touch the engine or muffler while the engine is running** or immediately after stopping the engine. These areas may be hot enough to cause serious burns.
23. When leaving the machine unattended, **disengage the blade clutch (PTO), engage the parking brake, stop the engine, and remove the key.**



Use leg muscles and firm footing when lifting the catcher to dump; avoid bending at the waist and using back muscles in order to prevent back injury.

Safety Instructions - Maintenance

1. To prevent accidental starting of the engine when servicing or adjusting the machine, remove the key from the ignition switch and disconnect the spark plug wires.
2. **To reduce fire hazards**, keep the engine free of grass, leaves, excessive grease, and dirt.
3. Keep all nuts, bolts, and screws tight to ensure the machine is in a safe, working condition. Check the blade mounting nuts frequently, making sure they are tight.
4. **Perform only maintenance instructions described in this manual.** Unauthorized maintenance operations or machine modifications may result in unsafe operating conditions.
5. If the engine must be running to perform a maintenance adjustment, keep hands, feet, and clothing away from moving parts. **Do not wear jewelry or loose clothing.**
6. **Always use the proper engine service manual when working on the engine.** Unauthorized maintenance operations or modifications to the engine may result in unsafe operating conditions.
7. Altering the equipment or engine in any manner which adversely affects its operation, performance, durability, or use will **VOID the warranty** and may cause hazardous conditions.
8. Never attempt to disconnect any safety devices or defeat the purpose of these safety devices.
9. Do not change the engine governor settings or overspeed the engine. The governor has been factory-set for maximum-safe engine operating speed.
10. **Use genuine factory replacement parts.** Substitute parts may result in product malfunction and possible injury to the operator and/or others.
11. **Use care when charging the battery** or performing maintenance on the battery and electrical system:
 - a. Make sure the battery charger is unplugged before connecting or disconnecting cables to the battery.
 - b. Charge the battery in a well-ventilated space, so gases produced while charging can dissipate. Make sure the battery vents in the caps are open.
 - c. Keep sparks, flames, and smoking materials away from the battery at all times. To avoid sparks, use care when removing battery cables from posts.
 - d. Disconnect both battery cables before unplugging any wiring connectors or making repairs on the electrical system.
12. Do not attempt to service the engine fuel injection system, which contains high pressure fuel and may cause injury if mishandled. For service of the pressurized fuel system, including the fuel pump module, fuel lines, and fuel injectors, contact your Walker dealer or authorized Kohler service dealer.

IMPORTANT: Keep all applicable manuals immediately accessible to anyone who may operate or service this machine.

Safety Instructions

SAFETY, CONTROL, AND INSTRUCTION DECALS

Safety, Control, and Instruction Decals are installed on the machine; if any are missing, illegible, or damaged, a replacement should be ordered and installed before putting the machine into operation. The Decal Part Number is listed below and in the Parts Manual.



Location: Adjacent to Blower Discharge Chute through Body
Part Number: 8600-4

1. Warning - rotating impeller is a cutting/dismemberment hazard to fingers and hands.
 - Never reach down into the blower discharge chute.
2. Warning - thrown object hazard.
 - Never engage the PTO with grass catcher raised.

IMPORTANT - ENGINE COOLING SYSTEM MAINTENANCE
 CHECK AND CLEAN ENGINE ROTATING INLET SCREEN AND STATIC SCREEN GUARD DAILY (EVERY 8 HOURS) OR MORE OFTEN IN DIRTY CONDITIONS. CYLINDER HEAD COOLING FINS SHOULD BE CHECKED AND CLEANED BY REMOVING ENGINE SHROUD EVERY 100 HOURS. 5869

Location: Engine Shroud
Part Number: 5855



Location: Rear Cross Member of Front Body
Part Number: 8600-16

1. Important - Lower front body before lowering catcher box.

REMOVE SCREEN FOR CLEANING
 TO RELEASE AND REMOVE SCREEN, OPEN CATCHER DOOR AND USE KNOBS TO PUSH BACK OF SCREEN FORWARD AND DOWN. 5869

Location: Rear of Grass Catcher Exhaust Screen
Part Number: 5869

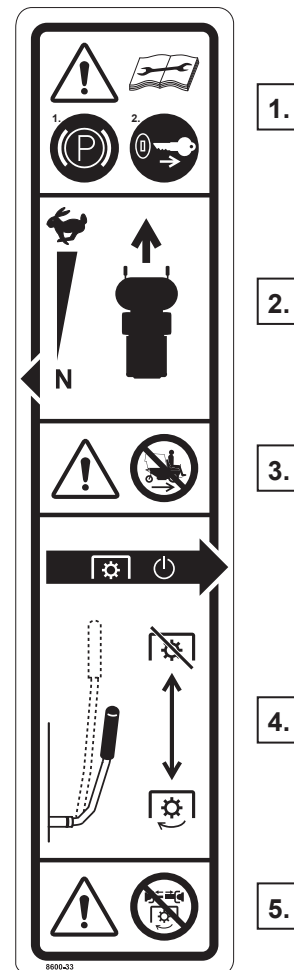

Location: RH Fender
Part Number: 8600-33

1. Warning – read Operator’s Manual before servicing or performing maintenance.
 - Engage parking brake.
 - Remove ignition key.
2. Forward Speed Control
 - Move lever forward to increase speed; back to stop.
3. Warning – do not operate the machine without a deck or other implement attached.
4. PTO Clutch Lever
 - Move lever forward to disengage PTO clutch; back to engage.
5. Warning – do not engage PTO clutch with PTO shaft disconnected.

Safety Instructions

SAFETY, CONTROL, AND INSTRUCTION DECALS

Safety, Control, and Instruction Decals are installed on the machine; if any are missing, illegible, or damaged, a replacement should be ordered and installed before putting the machine into operation. The Decal Part Number is listed below and in the Parts Manual.



1.

2.

Location: Each End of Mower Deck
Part Number: 8600-28

- Warning – thrown object hazard.
 - Keep bystanders away from the machine when operating.
 - Clear lawn of debris before operating.
 - Keep any discharge deflector in place and in the lowest position.
- Warning – rotating mower blades are a cutting/dismemberment hazard to hands and feet.
 - Keep all body parts away from rotating mower blades.
 - Do not step on end of deck.



1.

Location: Deck Carrier Frame
Part Number: 8600-14

- Warning – do not operate the machine with the deck tilted up.



1.

Location: Deck Carrier Frame
Part Number: 8600-15

- Warning – lock deck tilt-up hinge before operating the machine.



Location: Gear Axle
Part Number: 5810-1



1.

Location: Deck Discharge Shield
(SD Decks Only)
Part Number: 5848-2

- Warning – thrown object hazard.
 - Always keep the discharge shield in the lowest position when operating.
 - Do not remove the discharge shield.

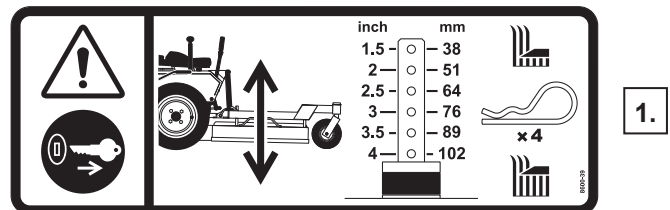

1.

Location: Deck Gearbox Cover
Part Number: 8600-39

- Warning - stop engine and remove ignition key before adjusting deck cutting height.

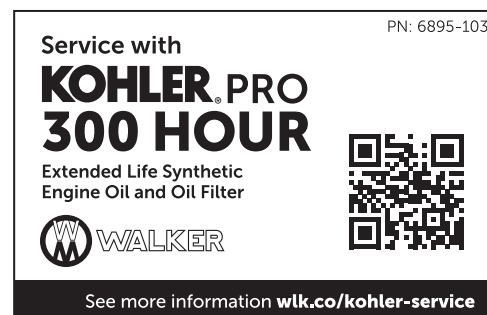

1.

Location: Engine
Part Number: 6895-103

- Change engine oil and oil filter every 300 hours.

Safety Instructions

SAFETY, CONTROL, AND INSTRUCTION DECALS

Safety, Control, and Instruction Decals are installed on the machine; if any are missing, illegible, or damaged, a replacement should be ordered and installed before putting the machine into operation. The Decal Part Number is listed below and in the Parts Manual.



1.

**Location: Catcher Door Hinge Bar,
LH and RH Sides**
Part Number: 8600-10

1. Caution - Pinch point.
 - Keep all body parts clear when closing grass catcher door.



Location: LH Gear Axle
Part Number: 5810-3



Location: Hydrostat Oil Reservoir
Part Number: 5810-23

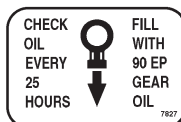

**Location: Jackshaft Support Adjacent
to Dipstick**
Part Number: 7827



1.

**Location: Front Body, RH Side Adjacent to
Operator Seat**
Part Number: 8600-30

1. Parking Brake
 - Move lever forward to engage Parking Brake; back to disengage.

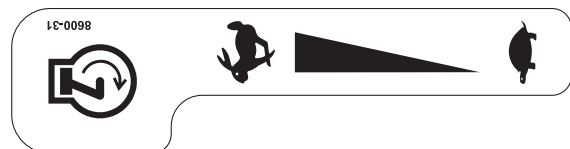

1.

**Location: Front Body, LH Side Adjacent to
Operator Seat**
Part Number: 8600-31

1. Throttle
 - Move lever forward to increase engine speed; back to idle.

Safety Instructions

SAFETY, CONTROL, AND INSTRUCTION DECALS

Safety, Control, and Instruction Decals are installed on the machine; if any are missing, illegible, or damaged, a replacement should be ordered and installed before putting the machine into operation. The Decal Part Number is listed below and in the Parts Manual.



Location: Front Body Adjacent to RH Steering Lever
Part Number: 8600-34

1. Warning – read Operator’s Manual before operating the machine.
 - Warning – wear eye and ear protection when operating the machine.
2. Warning – roll-over hazard.
 - Do not operate on slopes greater than 15 degrees.
3. Warning – thrown object hazard.
 - Keep bystanders away from the machine when operating.
4. Warning – entanglement hazard.
 - Keep all guards in place while engine is running.

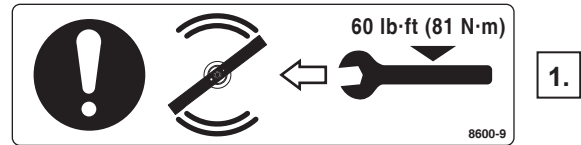

Location: Gearbox Cover
(Gear Drive Decks Only)
Part Number: 8600-9

1. Tighten blade nuts on gear-driven decks to 60 lb·ft (81 N·m).



Location: Front Body, LH Side Above Muffler
Part Number: 8600-12

1. Warning – carbon monoxide (CO) poisoning hazard.
 - CO emitted by a running engine can be deadly.
 - Do not operate indoors or in other enclosed areas.

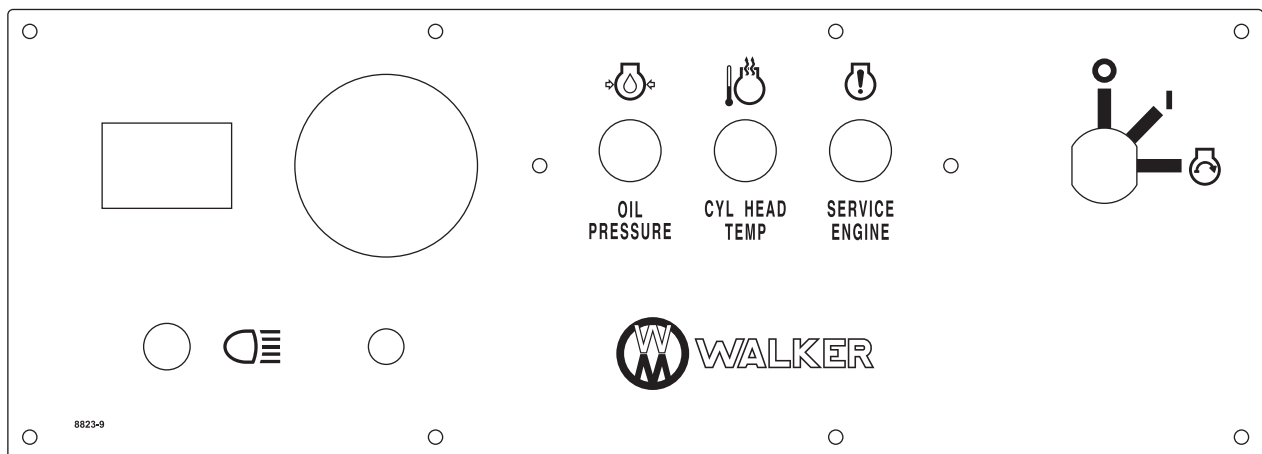

Location: Instrument Panel
Part Number: 8823-9

Assembly Instructions

SETUP INSTRUCTIONS

Walker Mowers are shipped partially assembled to our distribution network, and are typically assembled by the selling dealer. For any additional assembly besides the following, contact your Walker dealer.

Tire Installation (Tractor)

- Install the drive tires using the eight (8) lug bolts supplied with the Owner's Packet of materials. Bolts are torqued to 75 to 85 lb·ft (102 to 115 N·m). Drive tires are 18 x 9.50-8, 4-ply; rear tires are 13 x 4.50-6, 6-ply.
- Check and adjust the inflation of the tires. The tire inflation recommendations are:

Drive	=	15 PSI (103 kPa)
Tailwheel	=	20 PSI (137 kPa)

Battery Service

CAUTION

Important Battery Service, Installation, and Charging Tips for Electronic Fuel Injection Engines:

- Do not allow the battery cables to touch opposing terminals. When connecting battery cables attach the positive (+) cable to positive (+) battery terminal first, followed by negative (-) cable to negative (-) battery terminal.
- Never start the engine when the cables are loose or poorly connected to the battery terminals.
- Never disconnect battery while engine is running.
- Never use a quick battery charger to start the engine.
- Never "jump start" the engine using another source. Electricity fluctuations can damage the ECU (Electronic Control Unit).
- Always disconnect negative (-) battery cable lead before charging battery, and also unplug harness from ECU before performing any welding on equipment.

Raise front mower body up for battery access (refer to *Front Body Latch Release* in **Operating Instructions**). Check the battery for electrolyte level and charge. The electrolyte level should be at the bottom of the vent wells [1/4 to 1/2 in. (6 to 13 mm) above plates]. If the specific gravity is less than 1.225, the battery needs charging. If the battery has been shipped dry, or is wet but needs service, refer to the following instructions.

IMPORTANT: Make sure battery is securely mounted in the frame. A loose battery may cause damage to the case resulting in acid leakage and severe damage to the machine. A hazard may be created by damage to critical working parts and safety systems.

Wet Battery Service

If the battery has been shipped wet, but the electrolyte level is low or the battery needs to be charged then:

1. Fill each battery cell with distilled water to the bottom of the vent wells.
2. Charge battery. Refer to *Battery Charging* in this section.

Dry Battery Service

DANGER

Activating a battery can be dangerous. The battery should be taken to a reliable service station, battery store, or power equipment dealer where a trained technician can activate the battery safely. **DO NOT** attempt to activate the battery unless you are experienced in battery service work. The following activation and charging instructions are provided for use by a trained battery technician.

Assembly Instructions



DANGER

Battery electrolyte is a poisonous and corrosive sulfuric acid solution.

- Avoid spillage and contact with skin, eyes, and clothing - causes severe burns.
- To prevent accidents, wear safety goggles and rubber gloves when working with electrolyte.
- Neutralize acid spills with baking soda and water solution.

To fill (activate) battery with electrolyte (if battery has been shipped dry):

1. Remove the battery hold-down bar, disconnect the battery cables and lift the battery out of the tray.

IMPORTANT: Battery must be removed from the mower before filling with electrolyte.

IMPORTANT: Obtain and use only battery grade sulfuric acid electrolyte with a 1.265 specific gravity to activate the battery. **DO NOT** use water or any other liquid during initial activation.

2. Remove the filler caps and carefully fill each cell until the electrolyte is just above the plates.
3. After the battery is filled with electrolyte, replace the filler caps and charge the battery. Refer to *Battery Charging*.

Battery Charging



DANGER

BATTERIES PRODUCE EXPLOSIVE GASES

- Charge the battery in a well-ventilated area, so that gases produced while charging can dissipate.
- Keep sparks, flames, and smoking materials away from the battery at all times.
- Make sure the battery cap vents are open after the battery is filled with acid (check manifold vent on each cap).
- Make sure the battery charger is unplugged before connecting or disconnecting cables to the battery.

IMPORTANT: Always disconnect the negative (-) battery terminal before charging. Failure to do so can result in damage to the ECU.

1. Charge the battery at 15 amps for 10 minutes. **DO NOT** exceed 20 amps maximum recommended charging rate. Charge until specific gravity is at least 1.250. Total charging time should not exceed one (1) hour.
2. After charging the battery, adjust the electrolyte level to the bottom of the vent wells [1/4 to 1/2 in. (6 to 13 mm) above the plates].

IMPORTANT: **DO NOT** overfill the battery. Electrolyte will overflow through the vented caps onto parts of the machine and **WILL** result in severe corrosion.

3. Install battery.

Assembly Instructions

Battery Installation

IMPORTANT: Make sure battery is securely mounted in the frame. A loose battery may cause damage to the case resulting in acid leakage and severe damage to the machine. A hazard may be created by damage to critical working parts and safety systems.

Install the battery in the mower as shown in **Battery Installation** photo. Connect the positive (+) first and then the negative (-) cable to the proper battery terminal [red cable and boot connects to the **Positive (+) terminal**]. Slide the rubber boot up and over the battery post, making sure it covers the post completely to **prevent an electrical short**.

WARNING

Make sure the battery cap vents are open. Improper venting of the battery COULD cause a battery explosion.

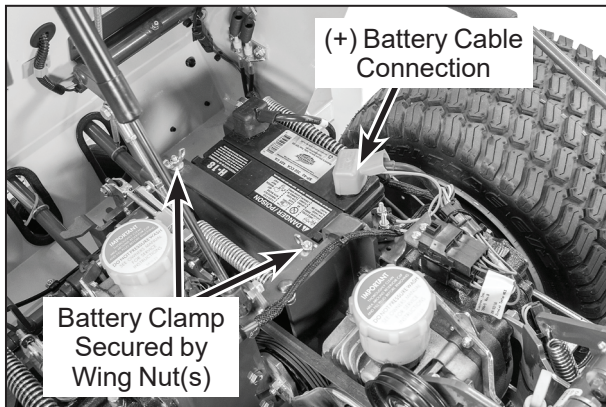

Battery Installation

Mower Deck Assembly

Deck Caster Wheels Installation

1. Remove the bolt and nut from each deck caster wheel fork.
2. Fit a bearing cup on the outside of each wheel bearing and slide the wheel assembly into the wheel fork.
3. Insert the 3/8-16 x 4-1/2 in. bolt through the wheel fork with the bolt head to the outside and install the 3/8-16 Keps nut.

4. Tighten the bolt and nut until the axle spacer tube and inner bearing race bottoms against the inside of the wheel fork (will not turn) while the wheel spins freely without binding.

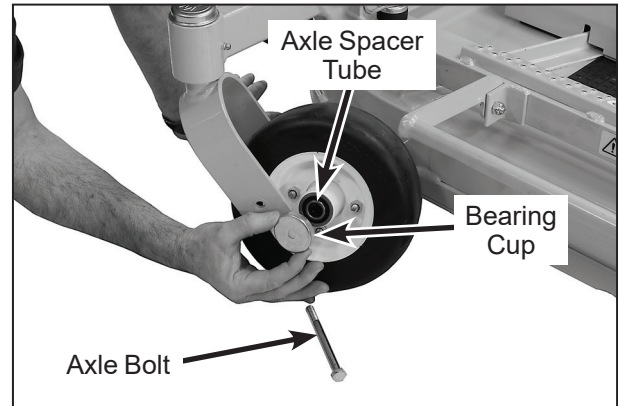

Deck Caster Wheel Installation

5. Grease the caster wheel bearings and caster pivot bearings - two (2) grease fittings for each wheel.

Deck Discharge Chute Installation (GHS Collection Models Only)

Mount the discharge chute hinge on top of the deck discharge opening using two (2) 1/4-20 x 1/2 in. carriage bolts and 1/4-20 ESNA nuts. Position the bolts with the heads inside the chute and the nuts on the outside. Attach spring for tilt-up action from chute to bracket on deck.

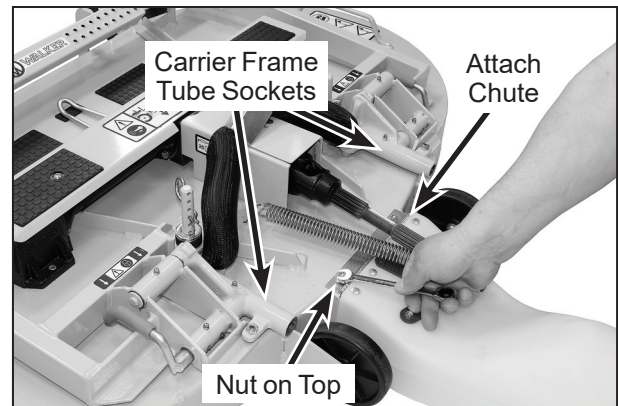

**Discharge Chute Installation
on Collection Deck**

Assembly Instructions

Deck Discharge Deflector Shield Installation (Side Discharge Models Only)

Attach the side discharge deflector shield using two (2) 3/8-16 x 1-1/4 in. bolts, 3/8-16 ESNA nuts, and 3/8 in. wave spring washers. The wave washers fit between the two hinging surfaces. Tighten the nuts until the shield moves freely but is not loose.



WARNING

DO NOT operate the machine without the grass deflector shield attached and in the lowest possible position.



**Discharge Shield Installation
on Side Discharge Deck**

PTO Shaft Guard Installation

Position the shaft guard as shown and mount with two (2) 1/4-20 x 1/2 in. bolts.

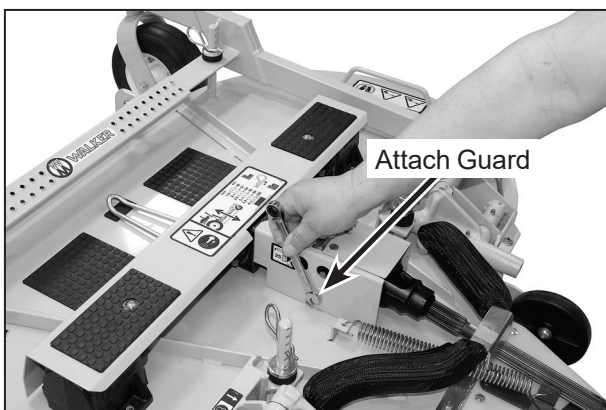

PTO Shaft Guard Installation

Tilt-Up Roller Wheel Installation

Mount the two (2) tilt-up roller wheels on the brackets on the rear skirt of the deck housing using the P/N F543 axle bolt, 3/8 in. plain washer, 3/8 in. wave spring washer (between bracket and wheel) and 3/8-16 Whiz locknut. Tighten the axle bolt until the wheel rolls freely, but is not loose.

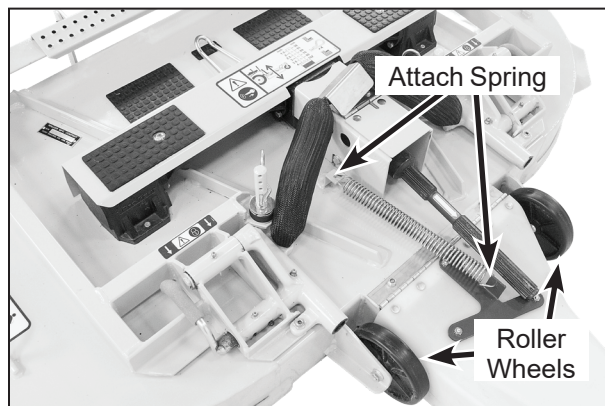

**Tilt-Up Spring and Roller Wheel
Installation on Collection Deck**

Mower Deck Installation on Tractor

Deck Installation

1. Lightly grease each deck support arm (2) on the tractor. Refer to **Mower Deck Installation** photo for location of deck support arm.

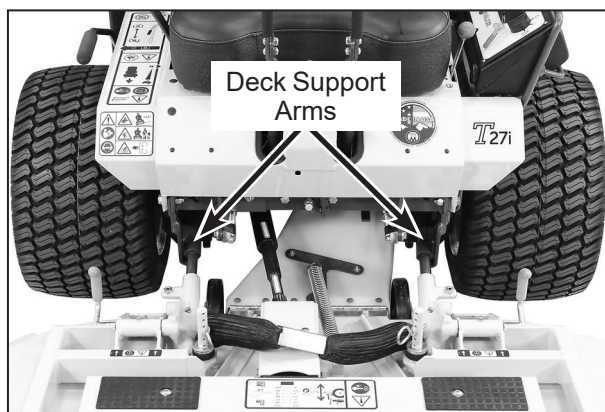

Mower Deck Installation

2. Engage the deck carrier frame tube sockets on the tractor support arms (refer to **Discharge Chute Installation** photo for socket location), slide the deck onto the support arms approximately 3 in. (76 mm).

Assembly Instructions

- Retract the spring-loaded quick disconnect ring on the PTO Coupler and insert the Coupler Installation Tool (provided in Owner's Packet) as shown in the **PTO Coupler Installation Tool** photo.

NOTE: The Coupler Installation Tool is provided for convenience, but is not required for installation.

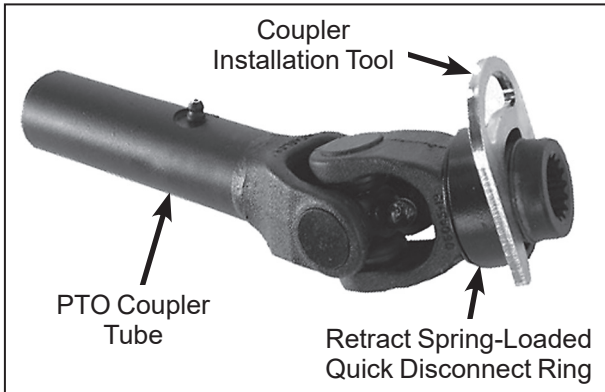

PTO Coupler Installation Tool

- Reaching under the tractor, slide the PTO coupler tube onto the deck drive shaft (align arrow decals), then install the coupler quick disconnect onto the tractor PTO drive shaft.

IMPORTANT: When installing the DS52 or DS62 Mower deck, make sure to retract the dolly wheel after mounting the deck on the tractor.

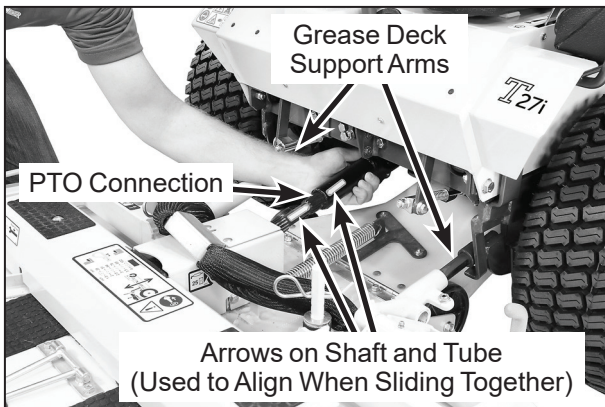

PTO Shaft Connection

- Remove Coupler Installation Tool from quick disconnect ring and make sure the ring has "snapped" securely on the spline shaft.

IMPORTANT: DO NOT operate tractor with Coupler Installation Tool installed.

IMPORTANT: To prevent damage to the mower, make sure the PTO quick disconnect is securely locked on the tractor, with the locking balls fully seated in the groove and the ring in the locked position (refer to the **Quick Disconnect Ring "Locked" Position** illustration). After installation, pull on the PTO coupler to check for security.

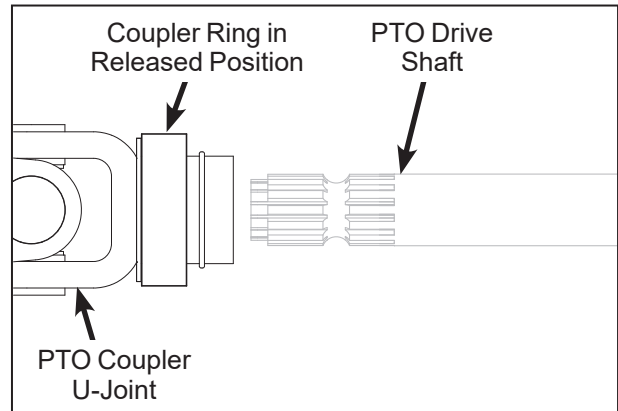

Quick Disconnect Ring "Released" Position

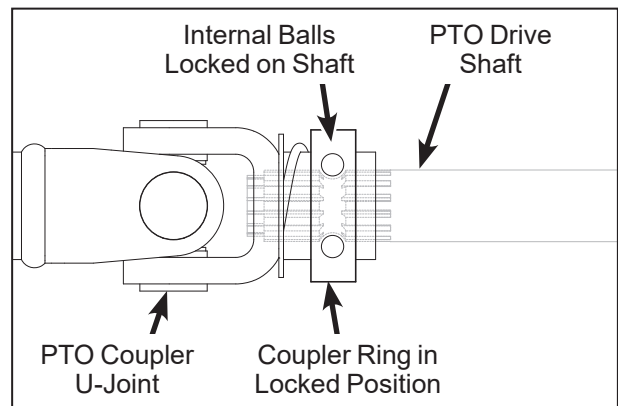

Quick Disconnect Ring "Locked" Position

- Slide the deck the rest of the way on the deck arms. If the deck is collection style (GHS equipped model), the discharge chute will need to be **aligned** and connected to the blower inlet during the last 2 in. (51 mm) of slide action on the support arms.

NOTE: Raising the mower body may be helpful in fitting and guiding the deck chute into the blower.

Assembly Instructions

7. Install the hitch pin through the hole on the end of each support arm to lock the deck in place (refer to **Deck Counterweight Spring Installation** photo). Two (2) hitch pins are included in the Owner's Packet of materials.
8. Raise the mower body (instead of lifting the front of deck) and clip the counterweight springs to the receptacle on front of body. Lower the body to tension the springs. (Refer to **Deck Counterweight Spring Installation** photo.)
9. With the counterweight springs connected, the weight on the deck caster wheels should be 15 to 25 lb (6.8 to 11.3 kg); this adjustment is preset at the factory. If required, the spring tension can be adjusted by tightening or loosening the elastic stop nuts located underneath the lower spring hook, or contact your local dealer if additional help is required. Refer to **Deck Counterweight Spring Installation** photo.

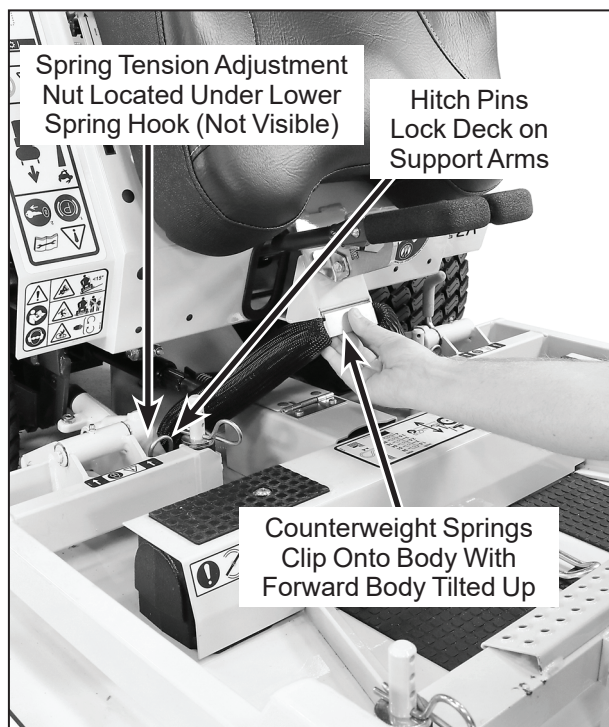

Deck Counterweight Spring Installation

Assembly Instructions

Deck Leveling

The mower deck and support frame are jig welded; within normal tolerances, very little, if any, shimming should be required to level the deck. Tire pressure will influence the levelness of the deck. Check the tire pressure of all pneumatic tires as a possible cause of the deck not being level.

1. Position mower on a smooth, level surface. Set the cutting height to the highest position - 4 in. (102 mm) - for easy access under the deck to measure blade height. Refer to **ADJUSTING CUTTING HEIGHT** in **Operating Instructions**.

NOTE: A block of wood cut **4 in. (102 mm)** high is a convenient gauge to measure blade height above ground during the leveling process.



WARNING

The machine must be shut off during this procedure.

2. Check the side-to-side level. **Rotate each blade sideways** and measure the distance from blade tip to ground on each side. If measurements vary more than 1/8 in. (3 mm), add a washer shim under the deck support pins on the low side to level the deck.
3. Check the front-to-rear level. **Rotate the blades to point forward**. Measure the distance from blade tip to ground on the front and rear. The rear of the blade should be 1/8 to 1/4 in. (3 to 6 mm) higher than the front of the blade; shim the rear (or front) deck support pins equally to achieve **at least 1/8 in. (3 mm)** difference.

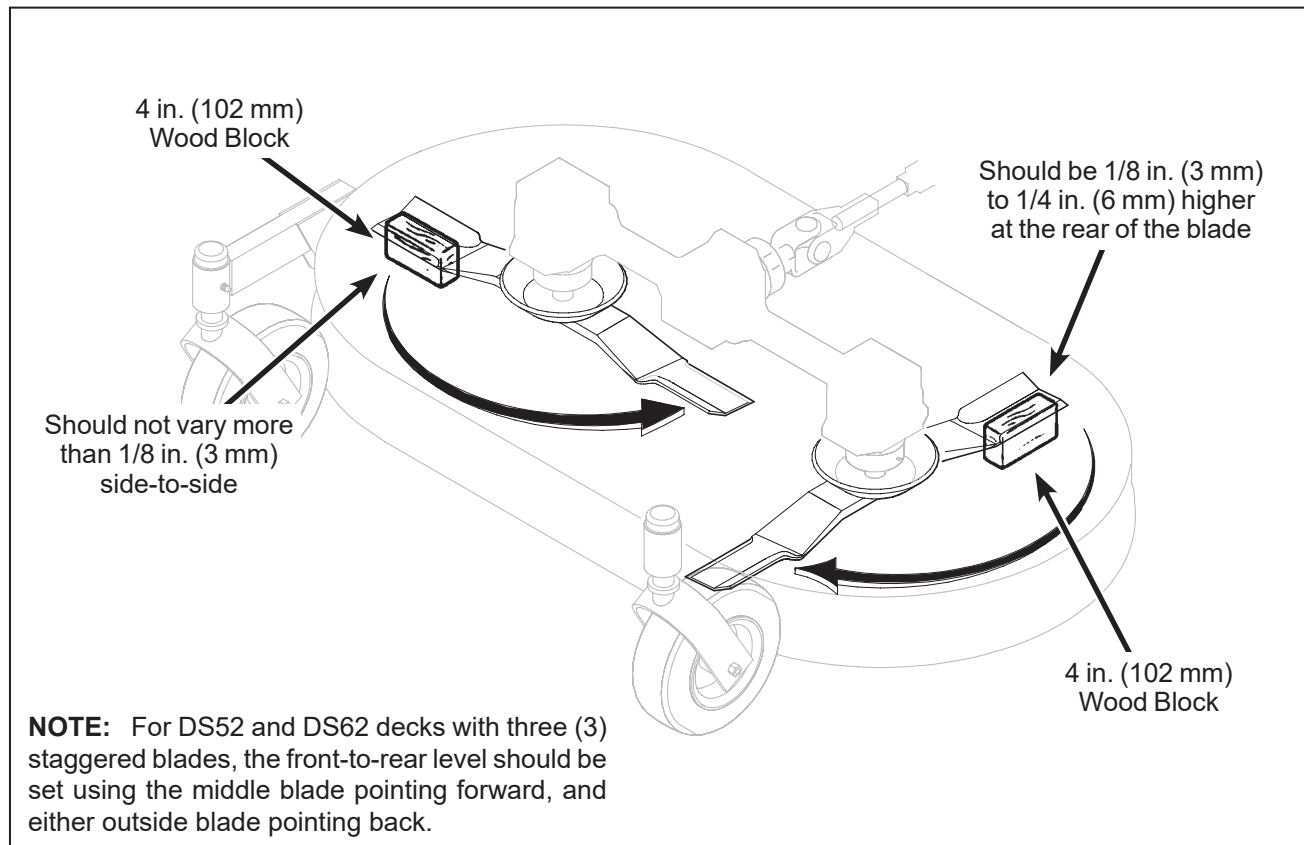

Deck Leveling

Assembly Instructions

PREOPERATING CHECKLIST

Before operating the mower for the first time, and as a routine before daily operations, it is important to make sure the mower is properly prepared and ready for operation. The following is a list of items to be checked. (For a mower with frequent operation, some of these items will not need to be checked every day, but the operator should be aware of the condition of each.)

For proper fuel and lubricants refer to **Specifications**.

FILL FUEL TANK

Fill the fuel tank using clean, fresh automotive grade **unleaded** gasoline (87 octane minimum, 10% ethanol maximum).



DANGER

Handle gasoline with care. Gasoline is highly flammable and its vapors are explosive. Use safe refueling procedures:

- **DO NOT** fill fuel tank with the engine running.
- **If the engine is hot, allow to cool before refueling.**
- **Use an approved fuel container.**
- **Fuel the mower outdoors.**
- **DO NOT** smoke while refueling.
- **Avoid spilling fuel; use a funnel or spout.**
- **DO NOT** overfill the fuel tank; fill up to about 1 in. (25 mm) below the top of tank.

IMPORTANT: **DO NOT** permit dirt or other foreign matter to enter the fuel tank. Wipe dirt from around the filler cap before removing. Use a clean fuel storage container and funnel.

IMPORTANT: **DO NOT** mix oil with gasoline. Always use fresh, automotive grade unleaded gasoline. **DO NOT** use gasoline containing greater than 10% ethanol. **DO NOT** use additives, such as carburetor cleaners, deicers, or moisture removing agents. **DO NOT** use gasoline blended with methyl alcohol.

CHECK ENGINE CRANKCASE OIL LEVEL

Check the engine crankcase oil level before use and **after each 8 hours** of continuous operation. Refer to **LUBRICATION** for *Checking Engine Crankcase Oil Level* in **Maintenance Instructions**.

CHECK AND SERVICE ENGINE AIR CLEANER SYSTEM

- Check air filter restriction gauge to make sure the yellow indicator disk is in the safe operating (green) range.
- Check condition, cleanliness, and security of the complete air cleaner system (inspect air filter paper element **every 100 hours**). For detailed procedures, refer to **CLEANING the Engine Air Cleaner System** in **Maintenance Instructions**.

CHECK ENGINE COOLING SYSTEM

Check that the engine cooling air intake screen is free of obstruction by grass clippings or debris and clean if required. Also, cylinder head cooling fins should be inspected and cleaned if any build-up of debris is noted [remove two (2) cylinder head access panels to inspect and clean]. Refer to **CLEANING the Cylinder Head Cooling Fins** in the **Maintenance Instructions** for this procedure.

Check performance of the cooling system by starting the engine, holding a hand adjacent to the cylinder heads, and feeling the cooling airflow.



DANGER

Make sure to keep hands clear of exhaust pipe, muffler, and moving parts when checking airflow.

CHECK GEAR AXLE OIL LEVEL

Refer to **LUBRICATION** for **Gear Axle Lubrication** in **Maintenance Instructions**.

INSPECT FOUR (4) DRIVE BELTS

Engine PTO Drive, Jackshaft Drive, Hydrostatic Ground Drive, and GHS Blower Drive (if equipped).

CHECK GRASS CATCHER EXHAUST SCREEN IS CLEAN (GHS MODEL)

Assembly Instructions

- CHECK HYDROSTATIC TRANSMISSION OIL LEVEL

Refer to **LUBRICATION** for *Checking Hydrostatic Transmission Fluid Level* in **Maintenance Instructions**.

- CHECK FUNCTIONS OF INSTRUMENT PANEL AND WARNING HORN

Turn the ignition key to the **ON (RUN)** position. Voltmeter, Oil Pressure Warning Light, and Warning Horn should all operate, indicating normal function.

- CHECK FUNCTION OF SAFETY INTERLOCK SWITCHES

Refer to **Operating Instructions** to check for proper operation of safety switches, both during engine starting and with the operator leaving the seat with tractor moving forward or with the mower blades engaged.

- CHECK TIRE PRESSURE

Deck Caster Wheel* = 20 PSI (137 kPa)
Drive = 15 PSI (103 kPa)
Tailwheel = 20 PSI (137 kPa)

* If equipped with optional pneumatic tires

- CHECK SECURITY OF DRIVE WHEEL BOLTS

The eight (8) lug bolts mounting the drive tires should each be torqued to 75 to 85 lb·ft (102 to 115 N·m).

- ADJUST MOWER CUTTING HEIGHT, IF REQUIRED

Position the hitch pins in the four deck support pins. Refer to the "Cutting Height Adjustment" decal on the deck gearbox cover.

- CHECK AND CLEAN GRASS BUILDUP UNDERNEATH MOWER DECK (and inside GHS blower, if equipped)

Refer to **CLEANING** the **GHS Blower** in **Maintenance Instructions** for blower cleaning information.



Never operate cutter blades with deck in raised position because it is hazardous.

The tilt-up deck can be secured in the raised position by unlocking the deck lock levers on each side of the carrier frame and inserting the deck hook into the tilt-up latch on the tractor body. Before operating the tractor, make sure to re-engage the deck lock levers after lowering the deck to the normal operating position.

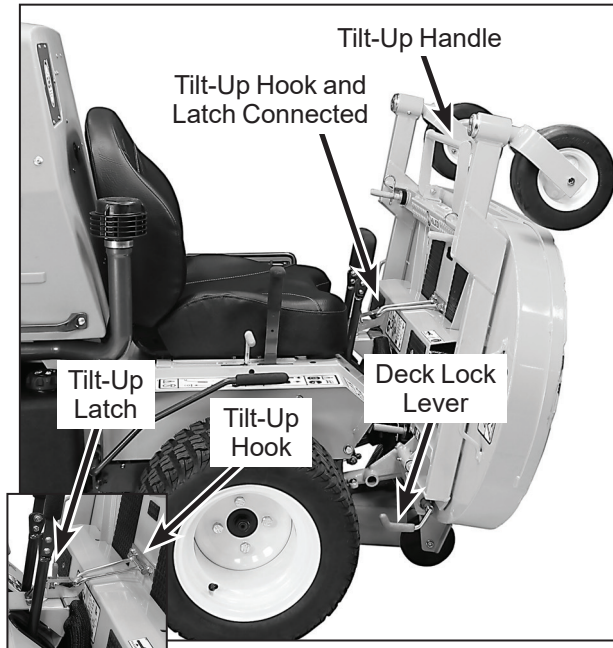

Deck Secured in TILT-UP Position



Do not operate machine with deck tilt-up pivot joint unlocked.



Do not operate the mower with deck in tilt-up position. Do not move the tractor with the deck in the tilt-up position.

- CHECK MOWER BLADE CONDITION, SHARPNESS, AND SECURITY OF MOUNTING

The blade mounting nuts on gear driven decks should be torqued to 60 lb·ft (81 N·m), and the blade mounting bolts on belt driven decks torqued to 70 lb·ft (95 N·m). If blade sharpening is required, refer to **CHECKING/SERVICING** for **Sharpen Mower Blades** in **Maintenance Instructions**.

- PERFORM ANY ADDITIONAL PROCEDURES called for on the **MAINTENANCE SCHEDULE CHART** in **Maintenance Instructions**.

Operating Instructions

CONTROL IDENTIFICATION, LOCATION, AND FUNCTION

Operating Controls

 **CAUTION**

Before operating the mower, become familiar with the location and function of all operator controls. Knowing the location, function, and operation of these controls is important for safe and efficient operation of the mower.

Engine Throttle

The throttle control lever (red knob) is located on the left side of the seat and is used to control engine speed. Moving the lever **forward** toward the **FAST** position **increases** engine speed; moving it **backward** toward the **IDLE** position **decreases** engine speed.

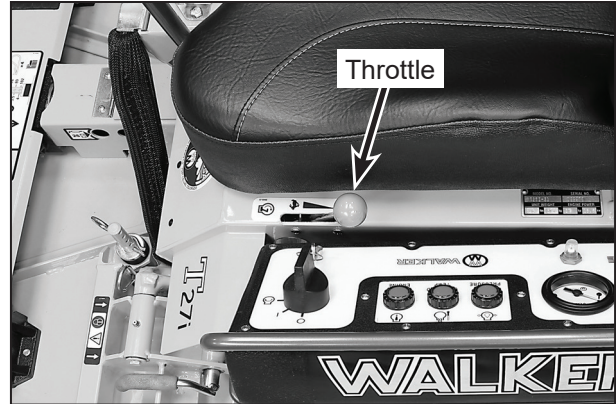

Throttle Location

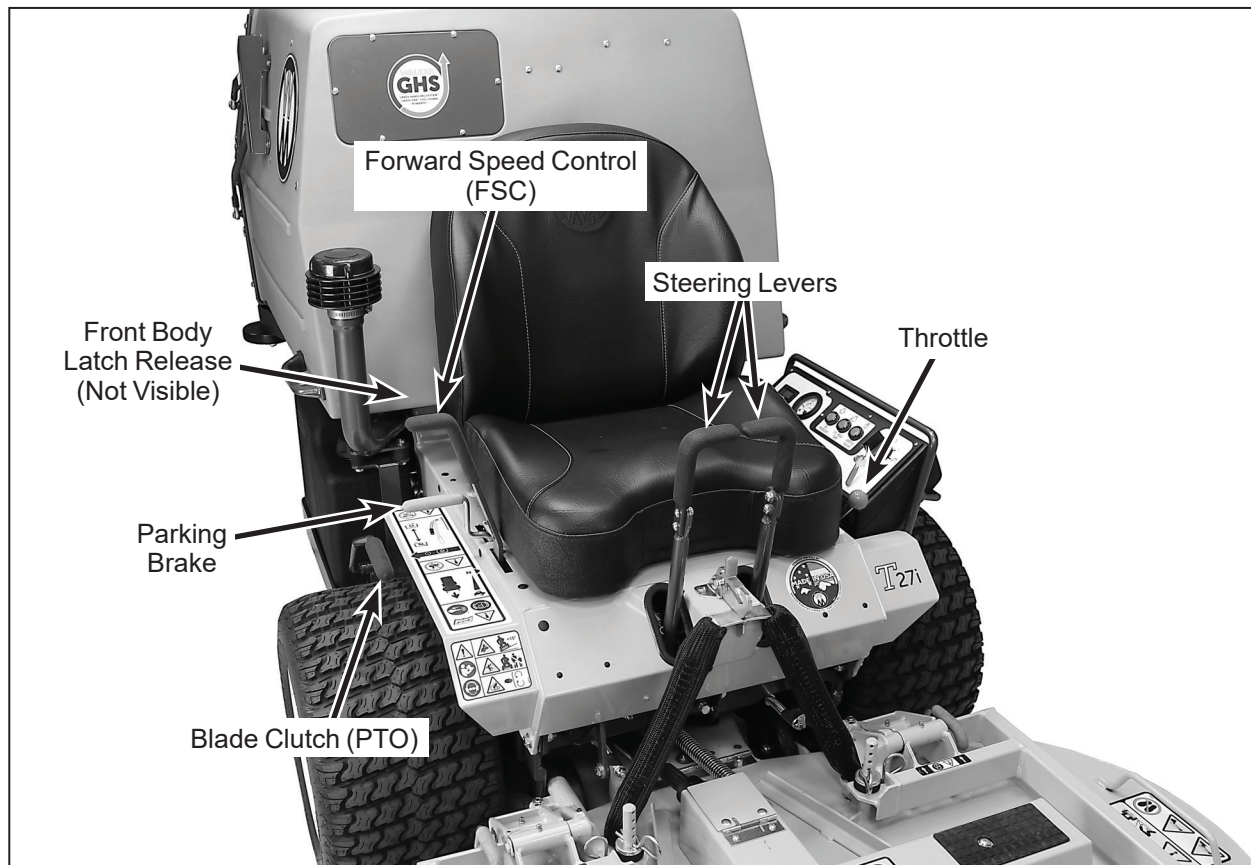

Operating Controls

Operating Instructions

Forward Speed Control (FSC)

Forward Speed Control (FSC) has two functions: One is to set forward travel speed, and the other is to establish the **NEUTRAL-PARK** position. When the FSC lever is moved into the **FORWARD** position, a friction lock holds any forward speed setting from 0 to 7 mph (0 to 11 km/h). The ground speed is proportional to the lever position; the further the lever is advanced forward, the faster the tractor moves. It is not necessary to hold the FSC in position since the friction lock maintains the selected lever position. Pulling back on the steering levers overrides the FSC setting and slows or stops forward travel. Releasing the steering levers allows the tractor to resume forward travel at the speed set by the FSC lever. To stop and park the machine, the FSC lever is moved backward to the **NEUTRAL-PARK** position.

Steering Levers

Each drive wheel is controlled by its own independent steering lever, for both steering function and **FORWARD/REVERSE** motion. The FSC lever sets the maximum forward speed, and also sets the forward position of the steering levers. The steering levers operate **only with a backward pulling** movement of the lever, which causes the drive wheel for that lever to first slow down, stop, and then reverse with a full backward lever stroke. The levers are released to the **FORWARD** position for “straight-ahead” ground travel.

NOTE: Pushing forward on the steering levers will not cause **any** change in tractor motion - there will be no steering lever reaction and there will be no machine damage.

Blade Clutch (PTO)

The blade clutch lever has two positions. Pulling the lever **UP engages** the PTO that drives the mower blades. Pushing the lever **DOWN disengages** the PTO and engages the blade brake.

NOTE: On GHS equipped models, the Powerfil[®] motor and Grass-Pak[®] full signal switch are activated by engaging the blade clutch. Refer to **Using the GHS Catcher** in this section for a complete description of GHS operation.

Front Body Latch Release

The front portion of the tractor body hinges forward for maintenance access and is latched down in the **OPERATING** position. To raise the body, pull the latch release up and forward.

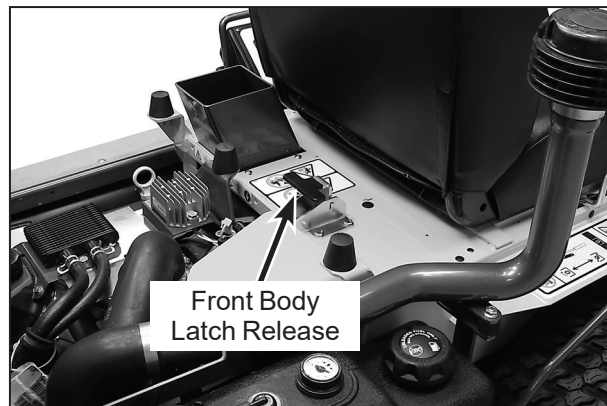

Front Body Latch Release

Operating Instructions

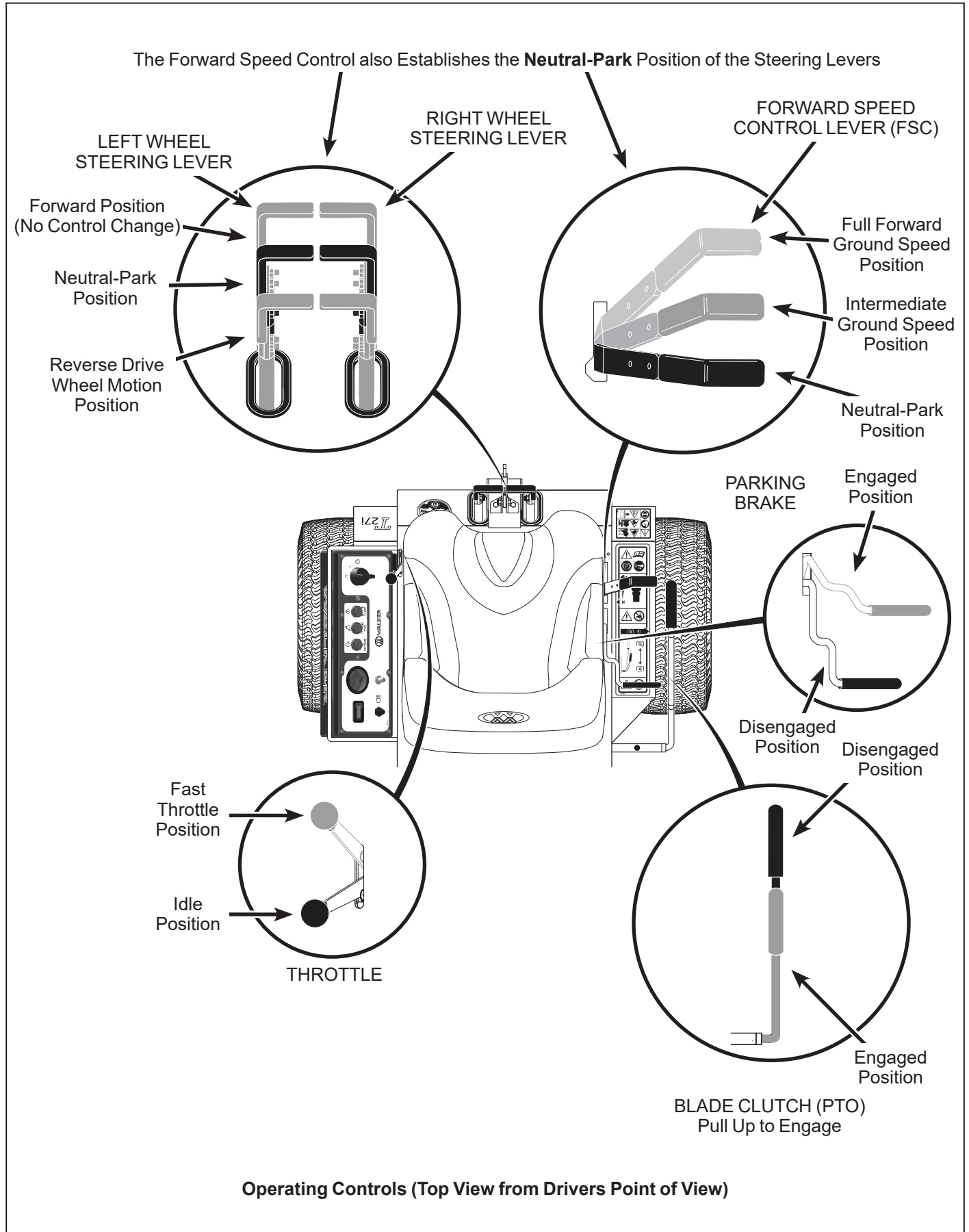

Operating Instructions

Parking Brake

The parking brake functions by locking a pin into the hydrostatic transmission pinion gear teeth. Moving the lever **FORWARD engages** the parking brake; moving the lever **BACKWARD releases** the brake.

IMPORTANT: Stop the tractor completely before engaging the parking brake. The parking brake uses a positive mechanical lock similar to the **PARK** position on an automotive automatic transmission. If the tractor is moving when the brake is engaged, it will result in sudden stoppage and possible internal damage to the axle drive.

NOTE: If pressure on the parking brake pin (e.g., parked on a hill) makes it impossible to release the parking brake with the parking brake lever, move the mower gently forward or backward to release the pin.



Parking Brake Engaged



Parking Brake Disengaged

Transmission Lockout Levers

The transmission lockout levers disengage the hydrostatic transmissions. By **lifting** the lever on top of the transmission and locking it into place with the lockout cam, the hydrostatic transmissions are released to permit freewheeling. By releasing the cam and **lowering** the lever, the transmissions are engaged for normal operation. The transmission lever in the **LOCKOUT** position is used to enable moving the machine without the engine running (e.g., for service). Refer to **TRANSMISSION LOCKOUT** in this section for operating instructions.

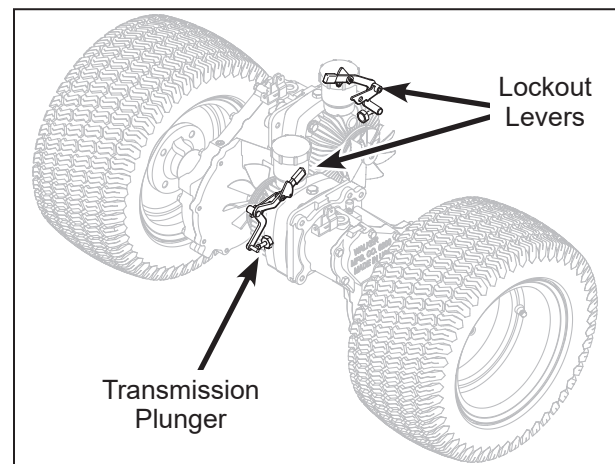

Lockout Lever Location

NOTE: The transmission plunger on the side of the transmission case (activated by the **LOCKOUT LEVER**) must be completely released during operation of the mower, otherwise operation of the transmission will be erratic.

Operating Instructions

Instrument Panel

This illustration shows the configuration of the **switches and indicators** located on the instrument panel.

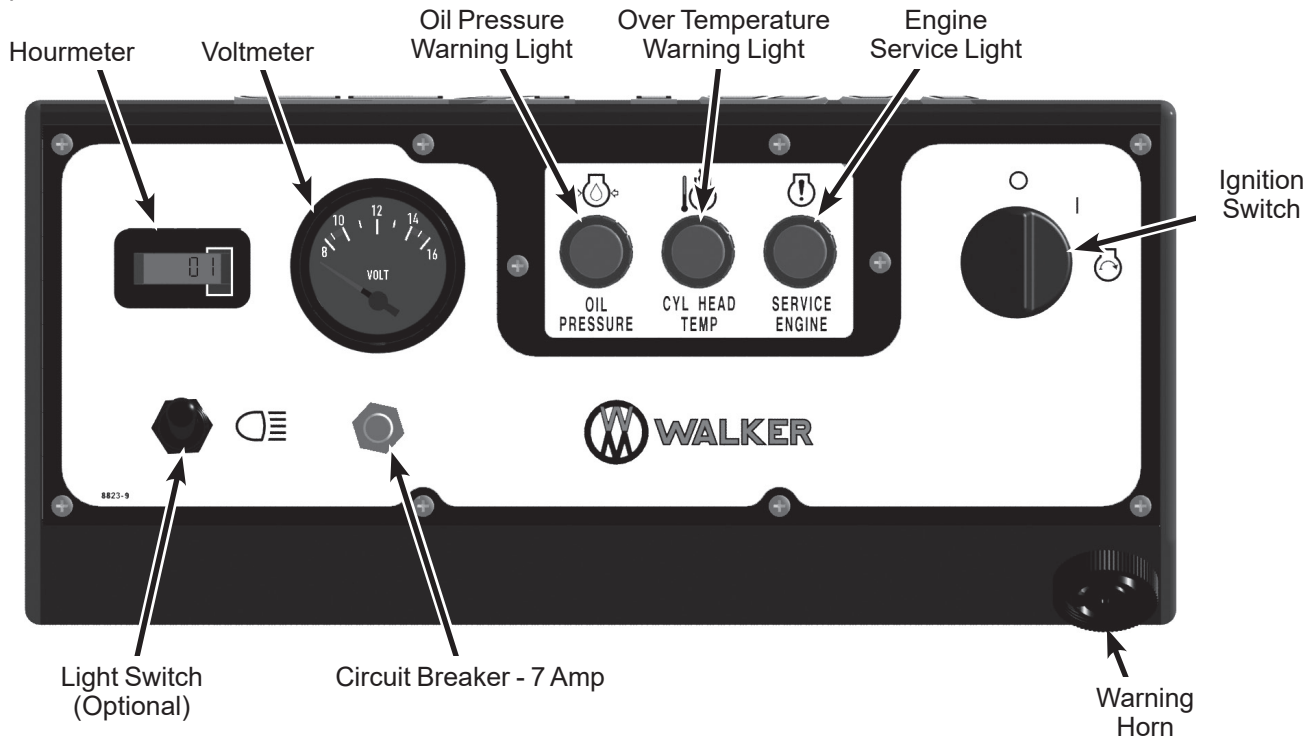

Instrument Panel

Hourmeter

The hourmeter, which is located on the instrument panel, displays **operating time** accumulated while the ignition switch is in the **ON (RUN)** position.

The hourmeter provides maintenance reminders after certain hours of operation. The hourmeter screen will start flashing the reminder one hour prior to the recommended interval and will continue until one hour after the recommended interval (two hours). The hourmeter **does not have a manual reset function**.

Procedure	Interval*	Reminder
Oil Change (Break-In)**	4-6 Hours	C H G OIL
Lubricate and Check Levels	24-26 Hours	LUBE
Oil Change	49-51 Hours***	C H G OIL

* These intervals reflect the actual time that the reminder will flash (one hour prior to and one hour after the recommended interval).

** This reminder is only used one time.

*** In normal operating conditions, oil changes in 100-hour intervals are acceptable. Walker and the engine manufacturers recommend engine oil changes every 50 hours in extremely dirty or dusty conditions or for units with less than 100 hours annual use.

Operating Instructions

NOTE: The hourmeter reminders are set for the most frequent service intervals. Follow the intervals outlined in the **MAINTENANCE SCHEDULE CHART**.

NOTE: The blinking hour glass on the display means that the meter is operating properly.

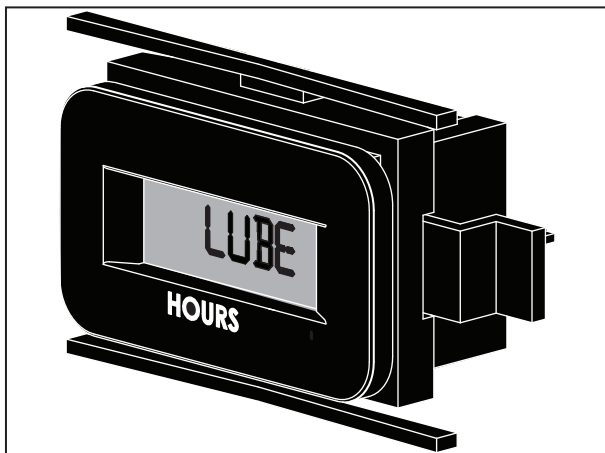

Hourmeter

Voltmeter

The voltmeter displays battery and charging system voltage. An indication of low or high voltage (the red area) indicates an **electrical system failure**. The cause of the failure should be determined and corrected.

Oil Pressure Warning Light/Horn

The oil pressure warning light and horn indicate that engine oil pressure is below the safe operating level [below 3 to 5 PSI (21 to 34 kPa)]. This **light (and warning horn)** will come on when the ignition is turned **ON**, but should go off after the engine is started. If the light fails to come on when the ignition switch is turned **ON**, it could indicate a burned out bulb. If the light comes on during engine operation, stop the engine immediately and correct the source of the problem before further engine operation.

IMPORTANT: Continued operation of the engine with an illuminated oil pressure warning light **MAY** cause severe engine damage (if a low oil pressure condition exists).

Over Temperature Warning Light/Horn

The over temperature warning light and horn indicate that the engine cylinder head temperature is above the safe operating limit (450° F or 232° C) and the **engine is overheating**. If this light comes on, there may be a problem with the engine cooling system (material packed into cylinder head cooling fins, clogged air intake screen, etc.). Stop the engine and correct the source of the problem before further operation.

IMPORTANT: Continued operation of the engine with an illuminated over temperature warning light **MAY** cause severe engine damage if a high cylinder head temperature condition exists.

Engine Service Light

The engine service light indicates that the engine Electronic Control Unit (ECU) has detected a fault in the engine performance. When this light illuminates during operation, contact an authorized Kohler Service dealer to diagnose the fault.

IMPORTANT: Continued operation of the engine with an illuminated engine service light will result in sub-standard performance and **MAY** cause engine damage if not corrected as soon as possible.

Operating Instructions

Ignition Switch

The ignition switch is used to start and stop the engine. The switch has three positions: "O" is the **OFF** position, "I" is the **ON (RUN)** position that the key returns to after starting, and  is the **START** position. When starting the engine, turn the key clockwise to the **START** position. Do not hold the key in the **START** position longer than 10 seconds. If the engine does not start, return the key to the "O" position for at least 60 seconds before making a restart attempt. Prolonged cranking can damage the starter motor and shorten battery life. Release the key when the engine starts, and it will return to the **ON (RUN)** position. To stop the engine, rotate the key counterclockwise to the "O" position.

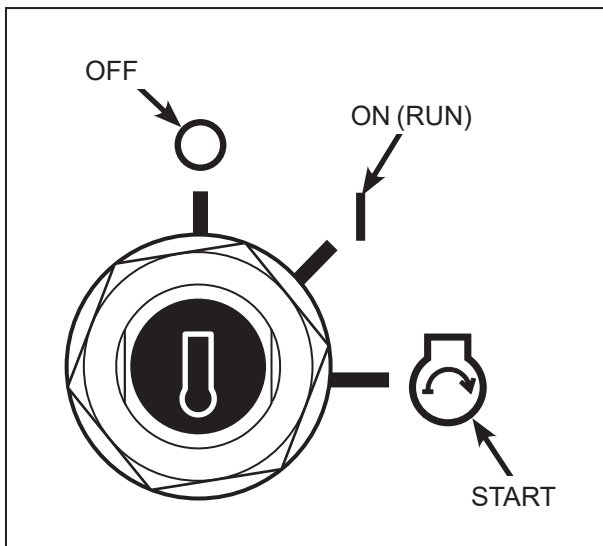

Ignition Switch

Light Switch (For Optional Lights)

Operates headlights (when installed).

Warning Horn

The warning horn sounds to alert the operator that an **unsafe engine condition** is being indicated—when engine temperature is too high or engine oil pressure is too low. If the horn sounds, check the indicator lights and correct the problem before further operation.

Circuit Breaker

One manual reset 7 amp circuit breaker is located on the instrument panel. A button pops out if the circuit breaker trips. The circuit breaker protects the safety circuits and GHS. In addition, an auto reset 30 amp master circuit breaker is located near the battery, and a 10 amp fuse protects the ECU.

STARTING THE ENGINE

CAUTION

Before operating the mower, read and understand all Safety Instructions and Operating Instructions.

WARNING

NEVER run the engine in an enclosed or poorly ventilated area. Engine exhaust contains carbon monoxide, an odorless and deadly gas.

1. Before attempting to start the engine, make sure the operator is in the seat, the Forward Speed Control is in **NEUTRAL-PARK** position, the parking brake is **ENGAGED**, and the blade clutch is **DISENGAGED**.

Operating Instructions

CAUTION

A safety interlock switch system **PREVENTS CRANKING** the engine with any one of these three controls in the **OPERATING** position: (1) Forward Speed Control out of neutral, (2) blade clutch (PTO) engaged, or (3) parking brake disengaged. If the engine cranks otherwise, the safety system is not working and should be repaired or adjusted before operating the mower. **DO NOT** disconnect safety switches; they are for the operator's protection.

2. Move the throttle 1/4 to 1/2 open (toward **FAST**). Turn the ignition switch to the **START** position to start the engine. Release the key to **ON (RUN)** position as soon as the engine starts.

IMPORTANT: If the engine fails to start after approximately 10 seconds of cranking, the engine should be checked before further cranking. Turn the key to the **OFF** position and allow a 60 second cool-down period between starting attempts. Failure to follow these guidelines can damage the starter motor and shorten battery life. Consult your Walker dealer or authorized Kohler dealer for additional help.

3. After the engine starts, make sure the oil pressure light goes off. If not, stop the engine immediately and find the cause of the problem. Make sure the oil pressure light is off prior to engaging the mower blades and beginning operation.

ADJUSTING GROUND SPEED AND STEERING

IMPORTANT: If the DS52 or DS62 mower deck is installed on the tractor, make sure the dolly wheel is retracted **BEFORE** moving.

CAUTION

Learn to **START, STOP, and MANEUVER** the mower in a large, open area.

If the operator has not operated a machine with **LEVER STEERING OR DUAL HYDRO-STATIC TRANSMISSIONS**, steering and ground operation should be learned and practiced until the operator is completely comfortable handling the machine **BEFORE ATTEMPTING TO MOW**.

DANGER

Keep feet on footrests at all times when the machine is moving. Never operate the tractor without a deck or implement installed.

1. Move the FSC out of **NEUTRAL-PARK** position to the desired forward speed. **DO NOT** hold forward on steering levers. It is not necessary to hold the FSC lever in position since a friction lock maintains the selected lever position (and forward travel speed).

WARNING

In case either of the transmission drive belts break during operation, and if the machine is on a slope, the machine will freewheel down the slope. To maintain control, immediately (1) Release the steering levers and simultaneously (2) Move the FSC to the **NEUTRAL-PARK** position. When the machine is stopped or moving slowly, engage the parking brake.

NOTE: This is exactly the same procedure used to normally stop and park the machine.

Operating Instructions

CAUTION

An operator presence switch (seat switch) will cause the engine to stop if the parking brake is in the DISENGAGED position and/or the FSC is out of the NEUTRAL-PARK position (tractor stationary or moving forward) and the operator is not in the seat. The function of this switch should be checked by the operator raising off the seat, first with the parking brake DISENGAGED, and then with the tractor moving forward (allow 1/2 second “off the seat” for the time delay function); the engine should stop. In each case, if the safety system is not working, it should be repaired or replaced before operating the mower. **DO NOT** disconnect the safety switches; they are for the operator’s protection.

NOTE: If the FSC lever will not stay in the selected position, the friction lock needs to be adjusted. Refer to **ADJUSTMENTS for FSC Friction Lock** in **Maintenance Instructions** or contact your Walker dealer.

2. Steer by pulling the lever on the side of desired direction of turn, e.g., pull the **LH** lever to **turn left**. To minimize the possibility of overcontrol, use only one hand on both steering levers.



**Correct Operator Hand Position
on the Controls**

Beginning Recommendations are:

- ◆ Learn operation of the mower in an open area away from buildings, fences, and obstructions. Learn operation on flat ground **BEFORE** operating on slopes.
- ◆ Start maneuvering the mower with **SLOW** engine speed and **SLOW** Forward Speed Control setting until familiar with all operating characteristics.
- ◆ Remember it is not necessary to hold the steering levers forward (a unique Walker feature); always **PULL** on the levers for steering or for reverse motion of the mower.
- ◆ Learn to operate the mower with your left hand on the steering levers and right hand on Forward Speed Control. The use of two hands on the steering levers tends to cause overcontrol.
- ◆ Learn to operate the steering levers with smooth action. Jerky movements are hard on the transmission and lawn. For sharp turns, do not allow the inside wheel to stop and twist on the grass. Pull the steering lever controlling the inside wheel into reverse for a smooth “rolling” turn (one wheel rolling forward while the other rolls backward).
- ◆ Practice maneuvering the mower until you can make it go exactly where you are aiming.
- ◆ Remember, for an emergency stop, or in case of loss of control, machine movement can always be stopped quickly by pulling the Forward Speed Control into the **NEUTRAL-PARK** position.

3. Reverse direction of the mower by pulling both levers backward.

NOTE: Smooth action on the steering levers will produce smooth mower operation. Remember to keep the engine and ground speed slow until learning the control response.

Operating Instructions

WARNING

When moving forward, **DO NOT** suddenly put the tractor in reverse by rapidly pulling on the steering levers, especially when going downhill, as this can lift the tractor tail wheel off the ground and set up a bucking motion due to operator overcontrol. If bucking does occur, immediately stop the bucking action by pulling the Forward Speed Control (FSC) lever into the **NEUTRAL-PARK** position.

4. The FSC may be adjusted forward for faster ground speed and backward for slower ground speed. When mowing, ground speed should be adjusted to match the load on the cutter blades, i.e., as the engine pulls down in heavy cutting, pull back on the FSC lever to reduce ground speed. Adjusting ground speed helps maintain a balance between engine power and blade speed for high-quality cutting action.

5. Stop ground travel by pulling both steering levers backward to the **NEUTRAL** position (tractor not moving) and then moving the FSC lever to the **NEUTRAL-PARK** position.

NOTE: If the tractor creeps forward or backward with the FSC lever in the **NEUTRAL-PARK** position, the transmission control needs to be adjusted. Refer to **ADJUSTMENTS** for **Transmission Control** and *Neutral Function Adjustment* in **Maintenance Instructions** or contact your Walker dealer.

ENGAGING THE BLADE DRIVE

1. Set the engine throttle at about 1/3 speed. **Do not attempt to engage the blade clutch at high engine speeds.** This will drastically shorten drive belt life. Use only moderate engine speed when engaging the blade clutch.
2. Engage the blade clutch by pulling the blade clutch lever **SLOWLY** up. For disengagement, push the blade clutch lever down **SLOWLY**.

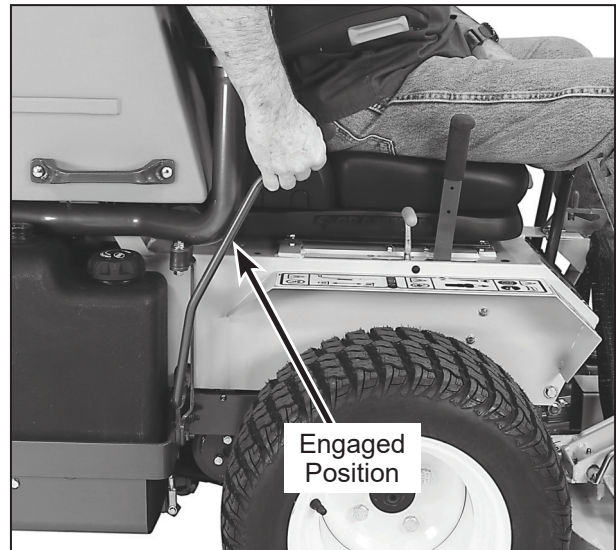

Blade Clutch Engaged



Blade Clutch Disengaged

Operating Instructions



CAUTION

An operator presence switch (seat switch) will cause the engine to stop if the blade clutch is engaged and the operator is not in the seat. The function of this switch should be checked by the operator raising off the seat and engaging the blade clutch; the engine should stop. If the switch is not working, it should be repaired or replaced before operating the mower. **DO NOT** disconnect the safety switches; they are for the operator's protection.

IMPORTANT: **DO NOT** engage the blade clutch when transporting the mower across drives, sidewalks, loose materials, etc. **DO NOT engage the blade clutch with the PTO shaft disconnected** (the mower deck removed from tractor).



CAUTION

If the cutting blades strike a stationary object while mowing, stop the mower immediately, disconnect the spark plug wires, lift the deck, and inspect the deck and blades thoroughly for damage. Make sure that the blade timing has not been disturbed (the blades should be at 90 degrees to each other). Refer to **REPLACING/REPAIRING the Blade Overload Shear Bolts** in Maintenance Instructions if blades are out of time. Also, make sure the blade retaining nuts are torqued to 60 lb·ft (81 N·m).

STOPPING THE MACHINE

1. Pull the steering levers to the **NEUTRAL** position and then move the FSC lever backward to the **NEUTRAL-PARK** position.
2. Slow the engine to a fast idle; put the throttle in the 1/2 throttle position.
3. Disengage the blade clutch.

IMPORTANT: **DO NOT** disengage the blade clutch with high engine speed (above 1/2 throttle) since the brake action on the blade drive will cause premature wear of the brake band.



WARNING

A brake stops the cutter blades (and blower on GHS equipped models) from freewheeling within five (5) seconds after disengaging the clutch. If the brake system malfunctions and the blades do not stop within five (5) seconds, the brake should be adjusted or repaired before operating the mower. Contact your Walker dealer, or refer to **ADJUSTMENTS of Clutch Disengagement/Brake Action** in Maintenance Instructions.

4. Slow the engine to idle, put throttle in **IDLE** position; turn the ignition switch **OFF**.



WARNING

Remove the key from the ignition switch when leaving the mower unattended. This will prevent children and inexperienced operators from starting the engine.

5. Engage the parking brake.

IMPORTANT: The hydrostatic transmissions lock to prevent the mower from rolling freely with the engine stopped. However, if the mower is parked on a slope, it is necessary to **ENGAGE** the parking **BRAKE** to prevent the mower from creeping. This is due to a small amount of slippage in the hydrostatic transmissions, especially when transmission fluid is warm. Also, engaging the parking brake is recommended when stopping or parking the machine in a confined space with little tolerance for movement.

Operating Instructions

CAUTION

An operator presence switch (seat switch) will cause the engine to stop if the parking brake is in the **DISENGAGED** position and the operator is not in the seat. The function of this switch should be checked by the operator raising off the seat with the parking brake lever in the **DISENGAGED** position (tractor not moving and blade clutch disengaged); the engine should stop. **NOTE:** Allow 1/2 second “off the seat” for the time delay function. If the safety system is not working, it should be repaired or replaced before operating the mower. **DO NOT** disconnect the safety switches; they are for the operator’s protection.

WARNING

In case either of the transmission drive belts break during operation, and if the machine is on a slope, the machine will freewheel down the slope. To maintain control, immediately (1) Release the steering levers and simultaneously (2) Move the FSC to the **NEUTRAL-PARK** position. When the machine is stopped or moving slowly, engage the parking brake.

NOTE: The emergency stop procedure is exactly the same procedure as used to normally stop and park the machine.

ADJUSTING CUTTING HEIGHT

WARNING

The engine must be stopped before adjusting cutting height. Disengage the blade clutch (PTO), engage the parking brake, stop the engine, and remove the ignition key. Wait for all movement to stop before getting off the seat.

Cutting height is adjusted by positioning the four (4) retainer hitch pins in a series of six vertical holes on the deck support pins. Lift handles have been provided on each end of the deck to assist in raising the deck while positioning the hitch pins. Cutting heights range from 1.5 in. (38 mm) [top holes] to 4 in. (102 mm) [bottom holes] in 1/2 in. (13 mm) increments.

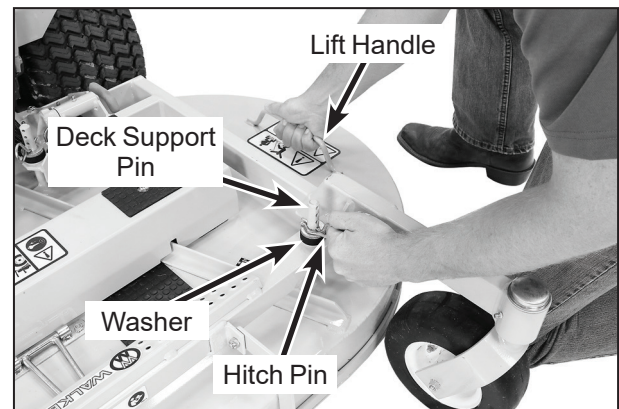

Cutting Height Adjustment

TRANSMISSION LOCKOUT

IMPORTANT: DO NOT TOW this mower with the transmission lockout engaged. Towing can produce excessive internal pressure and damage the transmission.

To move the mower with the engine **NOT** running (dead battery, maintenance, etc.), the hydrostatic transmissions are unlocked (released).

1. Raise the body.
2. Lift the transmission lockout lever on both the RH and LH transmissions and secure into place with the locking cam.
3. The mower will “freewheel” with the levers in the **LOCKOUT** position. The levers must be in the highest position to completely unlock the transmissions.

Operating Instructions

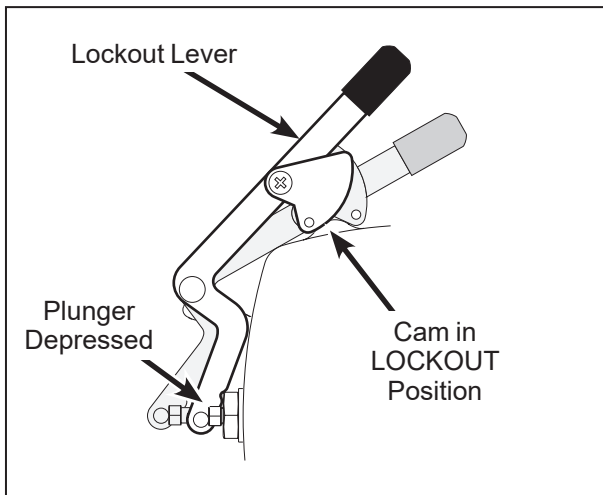

Lockout Lever - Freewheel Position

4. After moving the mower, release the locking cam, placing the lever **DOWN** in the normal **OPERATING** position. Make sure the transmission lockout plunger on the side of the transmission case (activated by the lockout lever) is **completely released**, otherwise the transmission operation will be erratic.

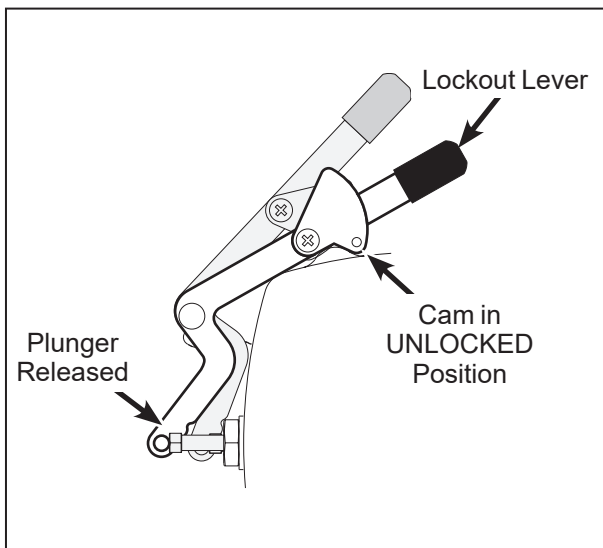

Lockout Lever - Normal Operating Position

RECOMMENDATIONS FOR MOWING



Do not mow around overhanging tree branches or bushes at the same height as the operator's torso and head where inadvertent contact may cause injury.

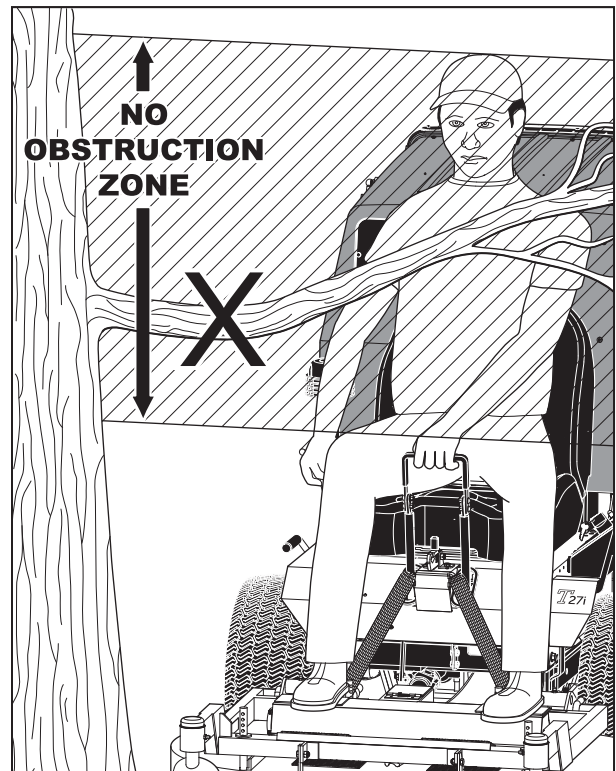

Avoid Low Hanging Branches

IMPORTANT: Operate the engine at **full throttle** when mowing, to allow the engine to produce full horsepower and to increase efficiency of the engine cooling system.

- Keep the mower deck and discharge chute clean.
- Mow with **sharp blades**. A dull blade tears the grass (resulting in poor lawn appearance) and uses extra power (slowing the mowing speed).
- It is preferable to cut grass when it is **dry** and **not too tall**. Mow frequently and do not cut grass too short. (For best appearance, cut off 1/3 or less of existing grass height.)

Operating Instructions

- When mowing, operate the engine at **full throttle** for the best cutting action and performance of the grass handling system (GHS). Mowing with a lower engine RPM causes the mowing blade to not cut clean and tear the grass. The engine is **designed to be operated at full speed**.
- When mowing in adverse conditions (tall and/or wet grass), mow the grass twice. Raise the mower to the highest setting - 4 in. (102 mm) - for the first pass and then make a second pass cutting to the desired height.
- Use a **slow** setting on the FSC for **trimming** operations.
- Make sure the mower is **leveled properly** for a smooth cut. Refer to *Deck Leveling* in *Assembly Instructions*.
- Use an alternating **stripe mowing pattern** for **best appearance** and vary the direction of the stripe each time the grass is mowed to avoid wear patterns in the grass.
- Avoid damage to the grass by slipping and skidding of the drive tires. Use **smooth control movements** of the steering levers since the hydrostatic transmissions are “power boosted controls” and jerking the levers can easily slip the tires. For sharp turns, do not allow the inside wheel to stop and twist on grass; pull inside steering lever into reverse for a smooth “rolling” turn (one wheel rolling forward while the other rolls backward).
- When using a side discharge mower deck, the side discharge deflector shield **must not be removed** and must be kept in the lowest possible position to deflect grass clippings and thrown objects downward. Orient the side discharge away from sidewalks or streets to minimize cleanup of clippings. When mowing close to obstacles, orient the side discharge away from obstacles to reduce the chance of damage to property by thrown objects.

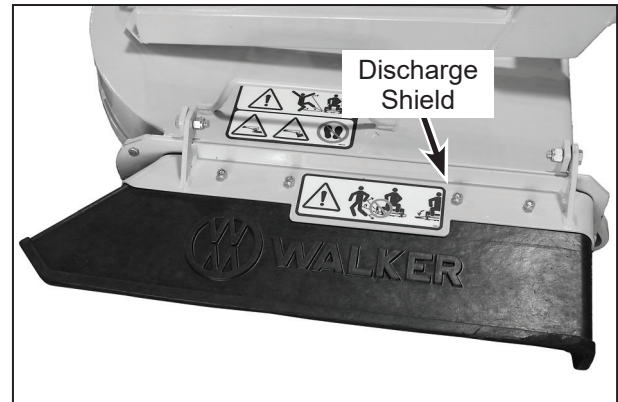

Side Discharge Deflector Shield in Lowest Position

- When operating on a slope, **reduce speed and use caution** to start, stop, and maneuver. Avoid sharp turns or sudden changes in direction. The **maximum recommended slope operating angle is 15 degrees or 27% grade**.

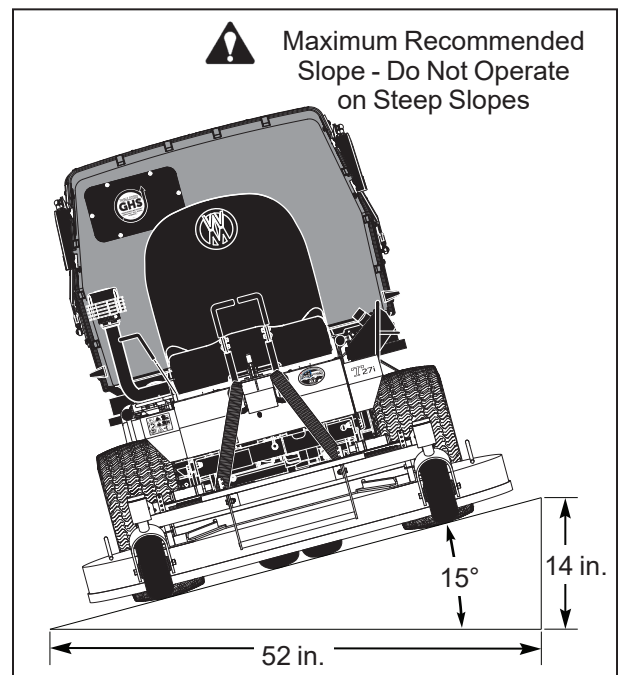

Maximum Recommended Slope

Operating Instructions

 **DANGER**

Do not mow or dump grass within 5 feet (1.5 meters) of an embankment or retaining wall with drop off.

RECOMMENDATIONS FOR TILT-UP DECK OPERATION/TRANSPORT

To avoid potential deck and/or tractor damage while using the tilt-up deck, the following recommendations are offered:

- **Do not move the tractor** with the deck in the tilt-up position since both the roller wheels (on the back of the deck) and the GHS discharge chute may be damaged by moving the tractor. The tilt-up configuration should only be used when the tractor is parked.
- The tractor **body should never be tilted forward** with the deck in the tilt-up position. This can cause the deck to unhook from the tractor and fall with considerable force, potentially causing deck or tractor damage and/or bodily injury.
- When transporting a tractor with the deck in the tilt-up position (on a truck or trailer), the **deck should be secured** to the vehicle with a strap or rope (stop vertical movement). This will prevent the deck from bouncing on the rear roller wheels (causing breakage). This will also prevent the deck from unhooking from the tractor and falling, potentially causing deck or tractor damage. Damage to other items parked in front of the deck may also occur.



No Driving Zone

Operating Instructions

GRASS HANDLING SYSTEM (GHS) GHS Model Only

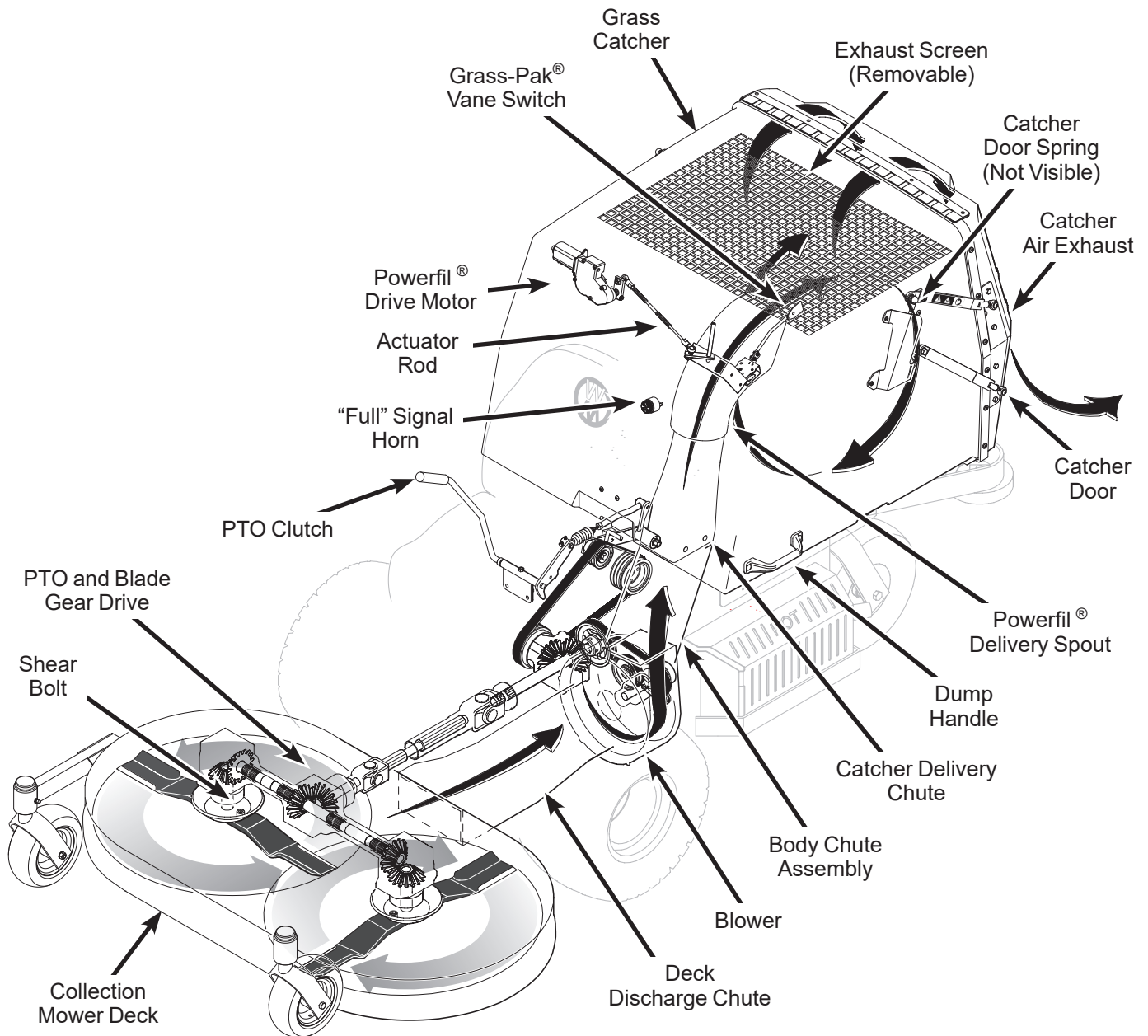

GHS Flow and Components

Operating Instructions

General Information

The Grass Handling System (GHS) consists of a rear discharge mower deck connected to a 10.5 in. (27 cm) blower and a rear mounted grass catcher with 10.0 bushel (352 liters) capacity. The GHS blower operates any time the mower blade clutch is engaged and moves grass through the rear discharge deck chute into the grass catcher. Blower airflow is exhausted out the back of the grass catcher, through a filtering screen. When the grass catcher is full and needs to be emptied, a **“full” signal horn alerts the operator**. When the “full” signal horn sounds, it is important to stop mowing to prevent overfilling and clogging of the blower system.

IMPORTANT: Normally, the GHS blower operates with no maintenance or cleaning required. However, under certain operating conditions, the inside of the blower housing may accumulate a deposit of dirt, causing wear and binding of the blower wheel. Normally, dirt buildup occurs when mowing a **combination of dirty and damp grass**, especially in the springtime. When operating in these conditions, **check the blower wheel frequently** for binding and clean the blower housing as required. Refer to **CLEANING the GHS Blower** in **Maintenance Instructions**.

NOTE: In Autumn, when using the GHS mower to vacuum leaves, it is recommended to raise the **front** of the mower deck 2 to 3 notches [1 to 1-1/2 in. (25 to 38 mm)] **higher than the rear**. This will avoid “bulldozing” leaves, particularly when the leaves are piled in a thick layer. To make this adjustment, the hitch pins in the **two (2) front** deck support pins are repositioned 2 to 3 notches higher while leaving the rear pins in their original position.

DANGER

NEVER operate the GHS catcher with the back door open. Objects may be thrown out the back of the catcher with sufficient force to cause serious injury to bystanders or property damage. **NOTE:** For non-catching operation, the “No-Catch” Deflector is an available accessory item.

NOTE: When a side discharge or mulching mower deck is installed on the GHS model, a blower intake cover should be installed in the blower intake tube. This cover “unloads” the blower and seals the intake to effectively eliminate power loss and blower noise when the blower is not being used.

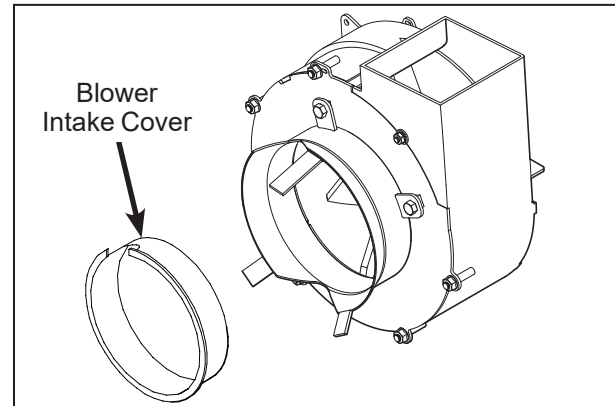

Blower Intake Cover

NOTE: An alternative to using the blower intake cover when a side discharge or mulching deck is installed on a GHS model is the blower lockout kit (P/N 7541-1). The blower lockout kit releases tension on the blower drive belt and does not require the blower intake cover.

DANGER

ROTATING BLOWER BLADES

NEVER operate the GHS blower with the blower discharge chute uncovered (grass catcher in the dump position) since dangerous projectiles may be thrown. **NEVER** put hands into the blower discharge chute for any reason. Use a stick or similar instrument to remove any material if clogging has occurred.

CAUTION

NEVER leave grass clippings in the grass catcher after mowing. Damp clippings generate heat as they decompose. This **MAY** cause spontaneous combustion.

Operating Instructions

Clogging Checklist

In case of clogging, there will be a **distinct change in the sound** of the blower, i.e., the blower sound will stop. Also, the mower deck will begin to leave a trail of grass clippings. When this occurs, stop the engine, disconnect the spark plug wires, and make **sure all movement has stopped before attempting to unclog**.

DANGER

NEVER place hands under the mower deck or in the GHS blower discharge chute. Use a stick or similar tool to remove any clogged material.

Normally, any clogging will first develop at the back of the mower deck in the discharge opening into the blower chute. Clogging at this point **does not indicate a particular problem in this part of the system, but is a symptom of something restricting the flow of material** throughout the entire system. The following list of items should be checked if a pattern of clogging begins to develop. All of these items are capable of causing clogging at the back of the deck.

- Check to see if the mower blades are installed **for the correct rotation**. The blade cutting edges should move towards each other at the front of the deck on standard rotation decks (e.g., DC48), and towards each other at the back of the deck on reverse rotation decks (e.g., DC52R).

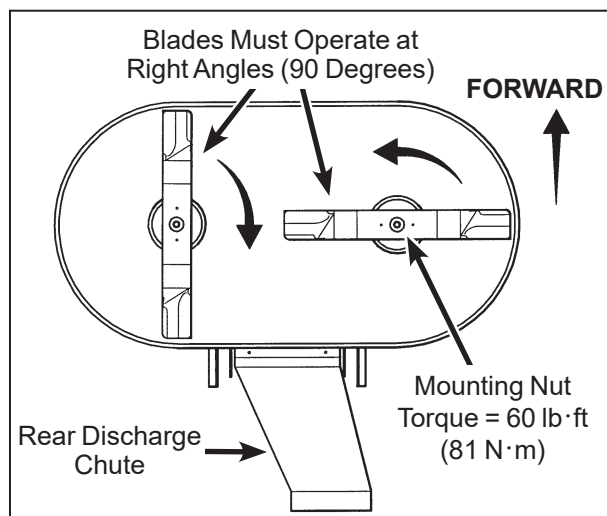

Blade Rotation for Standard Rotation GHS Mower Deck (Bottom View)

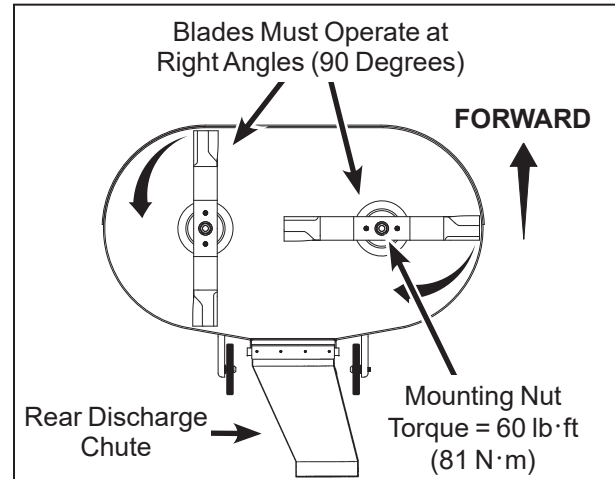

Blade Rotation for Reverse Rotation GHS Mower Deck (Bottom View)

- Check the amount of **flat section** remaining at blade tip. This is the area that is ground away (removed) when the blades are sharpened. If too much of the flat section is removed, the “air lift” performance or “shovel” effect of the blade deteriorates to the point that discharge of grass clippings into the blower chute is marginal. Replace cutter blades if less than 3/4 in. (19 mm) flat section remains at the blade tip.
- Check that the interior of the deck housing and baffling is reasonably **clean and free of grass and dirt buildup**. While some degree of material buildup can be tolerated, a point is finally reached where the flow of air and grass clippings is restricted.

NOTE: One condition that quickly causes a buildup of material in the deck housing is mowing grass and/or weeds which are “juicy.” The material collects under the deck with sticky, green juice. Clover and weeds are especially a problem. The mower deck will need to be cleaned frequently when operating in these conditions.

- Check the deck cutting height setting. When working in thick, tall grass, **lower deck settings [1 to 2 in. (25 to 51 mm) cutting heights] tend to restrict airflow** from moving into and under the deck. Raising the deck cutting height will significantly increase airflow and reduce clogging when working in thick, tall grass.
- Check the interior of the chute connecting the mower deck to the blower for **smoothness and freedom from obstruction**.

Operating Instructions

- Check the blower wheel for **bent blades and excessive clearance** between the blade tip and the blower housing. A clearance greater than 1/8 in. (3 mm) will cause a significant loss of blower performance.
- Check the blower discharge chute into the grass catcher for **smoothness and freedom from obstruction**.
- Check the elbow inside the grass catcher for a **buildup of material in the radius** of the elbow. In certain conditions (damp/dirty grass) a considerable “clump” of material can accumulate at this point, greatly restricting material and airflow.
- Check that the **openings in the removable air exhaust screen** in the grass catcher are not plugged. If the screen is clogged, refer to **Cleaning the GHS Exhaust Screen** in this section.

NOTE: An optional exhaust screen with larger holes (3/4") is available for use when mowing in wet grass; the screen provides less airflow restriction and more clog resistance (use standard screen in dry conditions to avoid excessive material blowing out of the catcher).

Remember, anything that restricts airflow or material flow along the entire path from the mower deck to the grass catcher can cause clogging.

Using the Tilt-Up Deck

Refer to **CLEANING of Grass Buildup in Mower Deck Housing** in **Maintenance Instructions**.

Using the GHS Catcher

Powerfil[®]

The GHS catcher has an oscillating grass delivery spout (**POWERFIL**[®]) which is designed to spread grass clippings throughout the interior of the grass catcher (even when mowing wet, heavy grass). The oscillating action may be checked by turning the ignition switch to the **ON (RUN)** position and moving the blade clutch to the **ENGAGED** position. The spout should oscillate approximately 35 cycles per minute.

NOTE: If the grass spout fails to oscillate, the clutch switch should be checked for function.

“Full” Signal Horn

The GHS catcher has a **“full” signal horn** to alert the operator to **dump the catcher when it is full** (to prevent overflowing and clogging). The “full” signal horn is activated by a vane switch (Grass-Pak[®] switch) mounted on the grass delivery spout. Oscillating action of the spout triggers the vane switch as grass begins to fill in around the spout when the catcher is almost full.

The “full” signal function may be checked by turning the ignition switch **ON (RUN)**, engaging the blade clutch (engine not running), opening the catcher back door, and triggering the Grass-Pak[®] vane by hand as it oscillates. The horn should sound as the switch is moved in one direction.

WARNING

DO NOT test the Powerfil[®] oscillation or Grass-Pak[®] switch with the engine running. Projectiles may be thrown out of the grass delivery spout, and COULD cause serious injury.

The “full” signal horn is designed to operate (sound) when the grass catcher is **almost full**. The timing of the signal is adjustable by changing the position of the vane on the Grass-Pak[®] switch. If the signal is coming on too soon (catcher not completely full) or too late (grass clogging in catcher spout and delivery chute), refer to **ADJUSTMENTS for GHS “Full” Signal Horn Adjustment** in **Maintenance Instructions**.

NOTE: The horn signal should be adjusted to sound **BEFORE the catcher is completely full** to give the operator time to react and stop mowing. An indication the horn signal is coming on too late (delayed too much) is if grass clippings are falling out of the grass catcher delivery chute when the catcher is dumped.

Operating Instructions

Cleaning the GHS Exhaust Screen

To remove the grass catcher screen for cleaning, open the catcher door, push forward and pull down on the grass catcher screen knobs (on either side of the screen), and slide the screen out. Use a high pressure washer or water spray and brush to clean the screen.

Keeping the catcher exhaust screen clean and open is essential to good performance of the catching system. In some mowing conditions, e.g., wet and dirty, it will be necessary to clean the screen frequently to avoid clogging the mower deck, blower, and chutes due to airflow restriction.

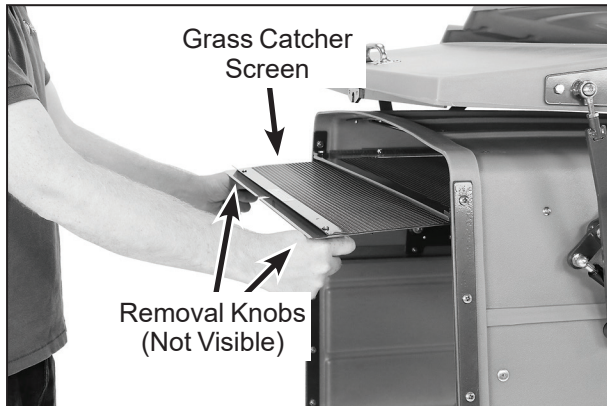

Grass Catcher Screen Removal for Cleaning

Dumping the Catcher

 **DANGER**

Do not mow or dump grass within 5 feet (1.5 meters) of an embankment or retaining wall with drop off.

For dumping, the catcher either tailgate dumps into a disposal area or dumps into the optional dump bag. The dump bag is a **reusable** nylon fabric bag designed to conveniently move grass clippings from the catcher to a remote disposal area or container.

 **CAUTION**

Use leg muscles and firm footing when lifting the catcher to dump; avoid bending at the waist and using back muscles in order to prevent back injury.

Tailgate Dumping

1. Open the back door by lifting on the door handle.
2. Tilt the catcher back to dump by lifting on the catcher lift/dump handle on the lower front corner of the catcher.
3. Lower the catcher smoothly down to the normal operating position. **DO NOT allow the catcher to drop down - the gas spring, that holds the catcher in the raised position, is not a shock absorber for lowering the catcher.**
4. Close the door by pulling down on the door handle. The door should close smoothly with the assistance of the gas springs. If the dampening springs are not functioning properly, they should be replaced to prevent the door from slamming closed and possibly causing a pinch point.

Operating Instructions

Using the Dump Bag

1. Open the back door by lifting on the door handle.
2. Orient the dump bag with one of the handle straps on the bag opening facing up.



Positioning Dump Bag on Catcher

3. Hook the bottom of the bag over the rear bumper while lifting on the handle strap on bag opening.
4. Tilt the catcher back to dump into the bag by **lifting on the catcher lift/dump handle** on the lower front corner of the catcher **with the one hand** while continuing to **hold up on the bag strap with the other hand**. Refer to photos for positioning the bag and dumping.



Dumping Catcher into Dump Bag

5. Lower the catcher smoothly down to the normal operating position. **DO NOT allow the catcher to drop down - the gas spring, that holds the catcher in the raised position, is not a shock absorber for lowering the catcher.**
6. Close the door by pulling down on the door handle. The door should close smoothly with the assistance of the gas springs. If the dampening springs are not functioning properly, they should be replaced to prevent the door from slamming closed and possibly causing a pinch point.

Operating Instructions

Power Dump Option

When equipped with the optional power dump system, the operator dumps the catcher while sitting in the seat. A toggle switch operating a power ram is used to raise and lower the catcher. The back door automatically opens and closes during the dump cycle.

Hold the toggle switch **UP** or **DOWN** to **RAISE** or **LOWER** the catcher. When the catcher reaches the full raised or lowered position, the power ram clutch will make a ratcheting sound. Release the toggle switch as soon as this sound is heard. **DO NOT operate the ram with the clutch ratcheting for an extended time** as this will cause extra wear on the clutch mechanism.

CAUTION

The operator should be in the seat and bystanders stay clear when the power dump is operating. The power dump is used **ONLY** for tailgate dumping. Do not attempt to use the optional dump bag or any other bag with the power dump.

NOTE: If grass tends to hang up in the catcher after raising the catcher with the power dump, “jiggle” the steering levers and make the tractor bounce a little to unstick the grass and make it slide out of the catcher.

NOTE: With the power dump mechanism in the normal operating position (catcher down), the catcher can be **manually raised** for access to the engine and the catcher can be **manually dumped**.

Hi-Dump® Option

When equipped with the optional Hi-Dump® system, the operator raises and dumps the catcher while sitting in the seat. Two toggle switches operate independent hydraulic cylinders to raise and lower, and dump the catcher. The back door automatically opens and closes during the dump cycle.

NOTE: The ignition switch must be in the **ON (RUN)** position for the Hi-Dump® system to operate.

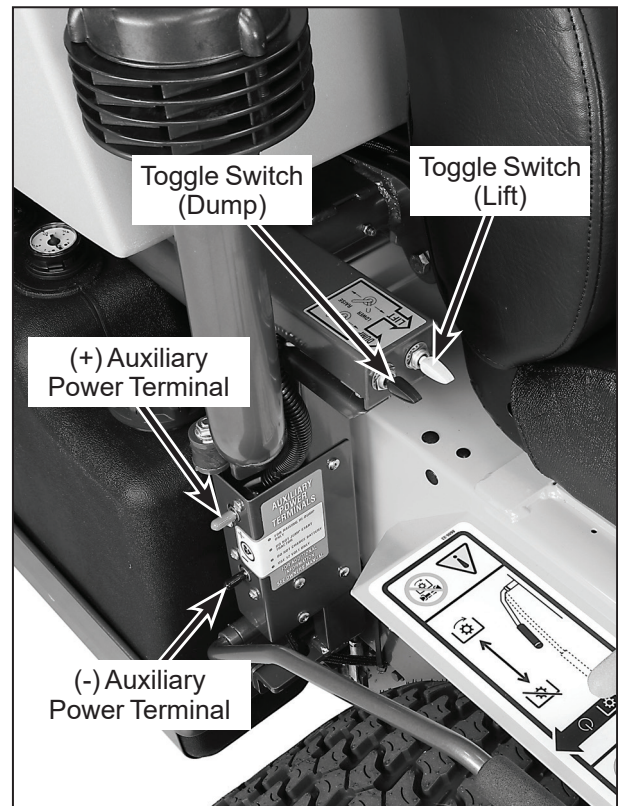

Lift/Dump Control Switches and Auxiliary Power Terminals

Hold the Lift toggle switch **UP** or **DOWN** to **RAISE** or **LOWER** the catcher. Hold the Dump toggle switch **UP** to **DUMP** the catcher and **DOWN** to return to the normal operating position. The catcher may be dumped at any raised position (Normal Operating - Intermediate - Fully Raised).

Operating Instructions

NOTE: If grass tends to hang up in the catcher after raising the catcher with the Hi-Dump®, “jiggle” the steering levers and make the tractor bounce a little to unstick the grass and make it slide out of the catcher.

NOTE: With the Hi-Dump® mechanism in the normal operating position (catcher down), the catcher cannot be **manually raised**. In the case of a dead battery, use the auxiliary power terminals to charge/boost the battery to operate the Hi-Dump®.

CAUTION

The operator should be in the seat with the machine in the **NEUTRAL-PARK** Position and the parking brake engaged and bystanders stay clear when the Hi-Dump® is operating. To avoid tipping over, the machine should be parked on **LEVEL GROUND** when raising/dumping the catcher with Hi-Dump®. Do not attempt to use the optional dump bag or any other bag with the Hi-Dump®.

WARNING

When the Hi-Dump® is in the **RAISED** position for access to the engine and drivetrain, always **ENGAGE** the safety lock before service or repair work. Remember to **DISENGAGE** the lock before resuming operation of the Hi-Dump® (to avoid damaging the lock mechanism).

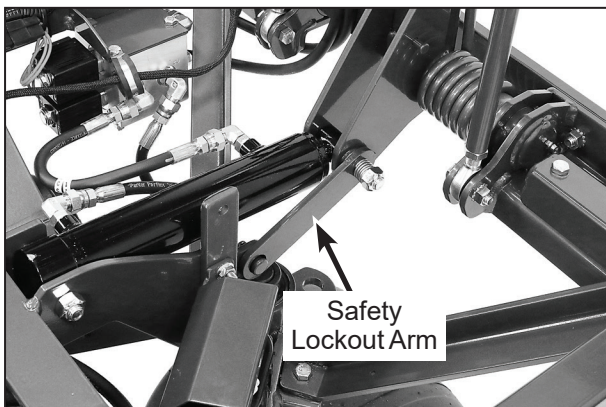

Safety Lockout Arm Engaged Position

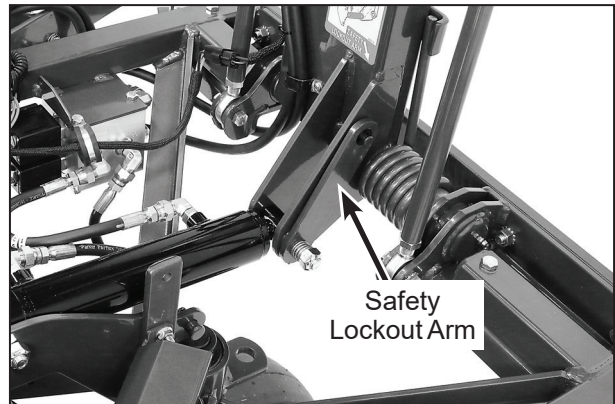

Safety Lockout Arm Disengaged Position



Decal, Safety Lockout Arm
(Location: Lower Lift Arm)

Operating Instructions

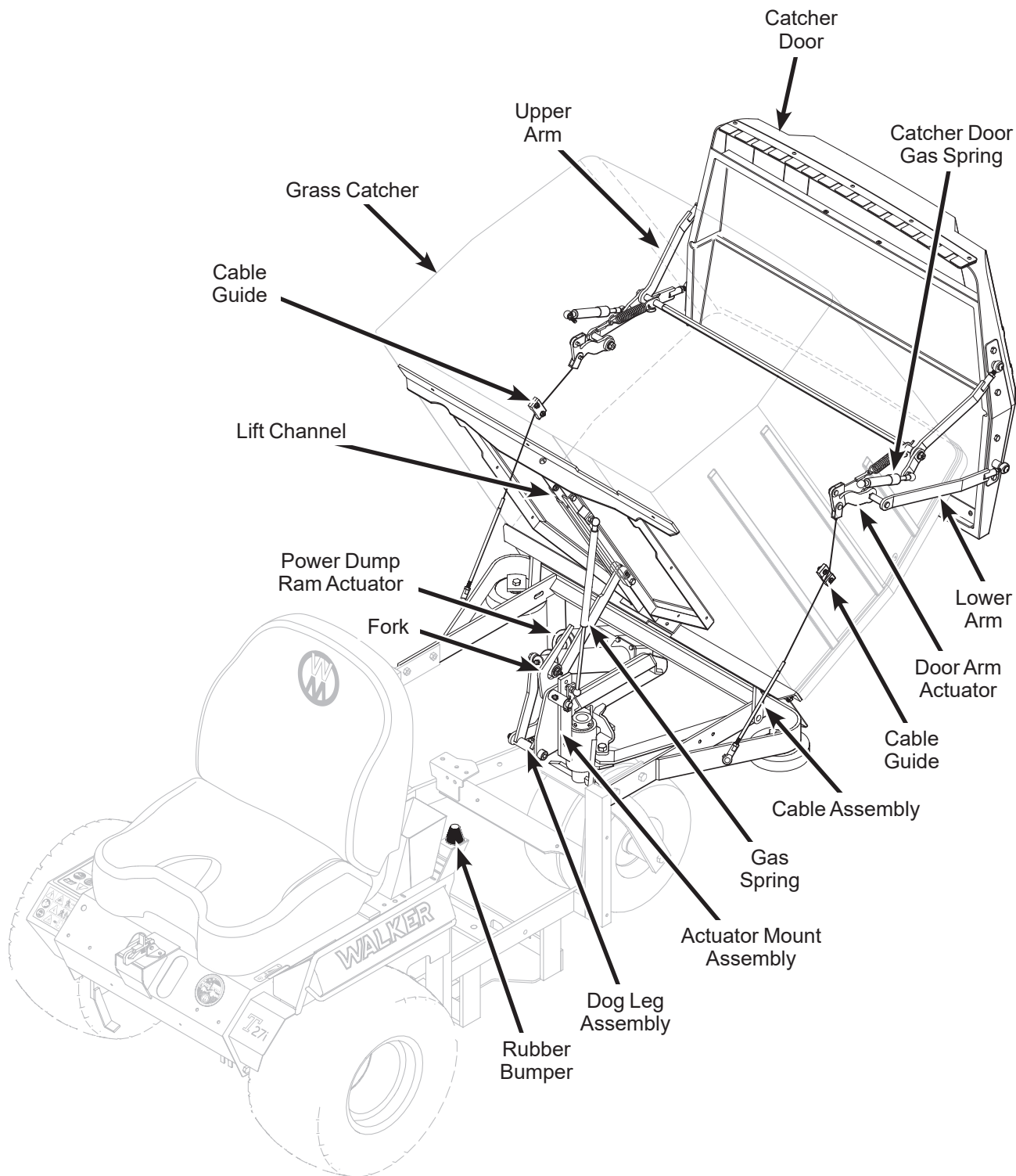

Power Dump Components

Operating Instructions

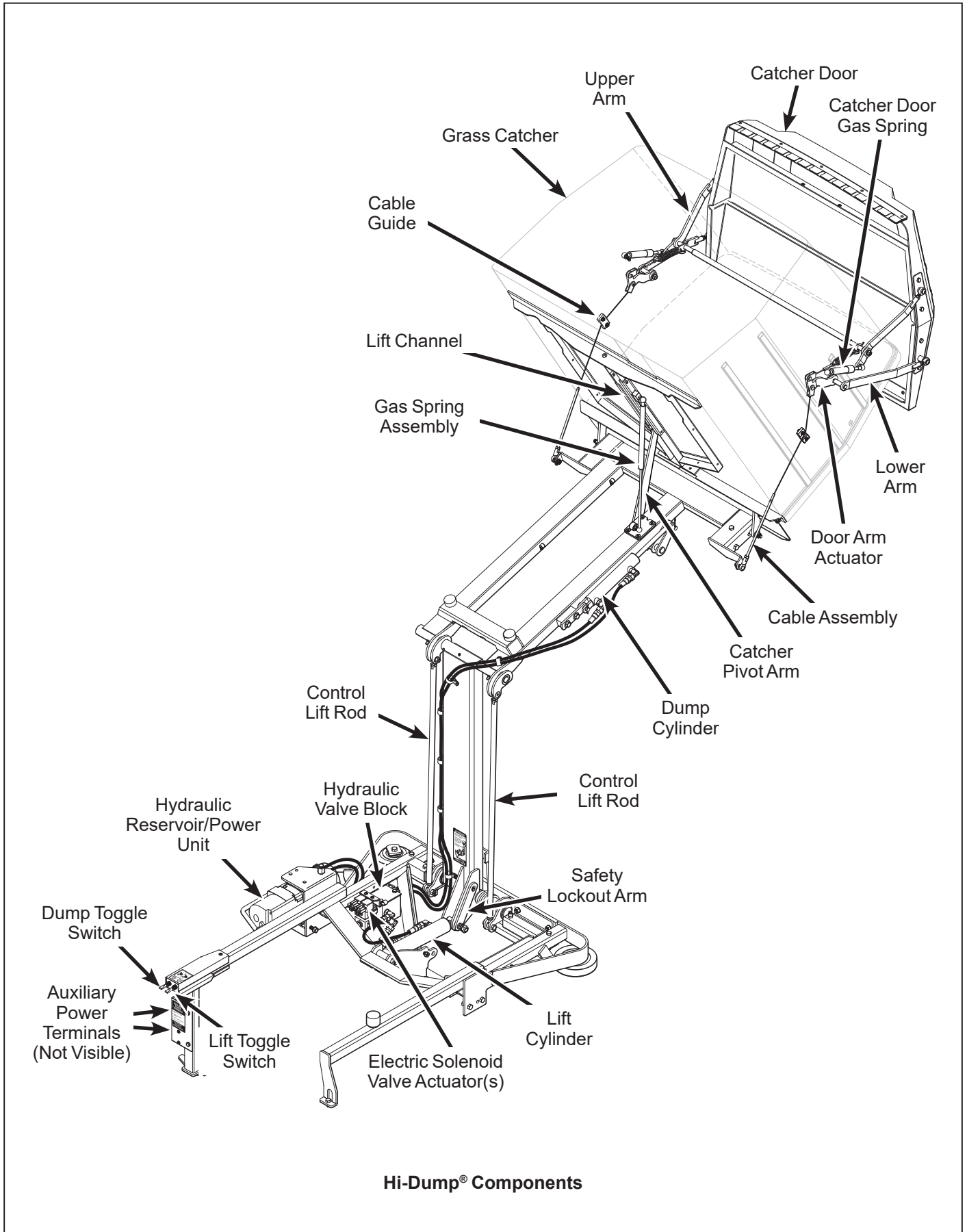

Maintenance Instructions



CAUTION

Maintenance procedures requiring special training or tools should be performed by a trained technician.

MAINTENANCE SCHEDULE CHART - RECOMMENDED SERVICE INTERVALS - MODEL T27i

Service Item	Daily	25 Hours	100 Hours	200 Hours	300 Hours	Yearly	Every 2 Years	Ref. Page
Check Engine Crankcase Oil Level	x							55
Check/Clean Engine Air Cooling System*	x							65
Check Security of Air Filtration Components	x							68
Check Air Filter Restriction Gauge	x							63
Clean Grass Buildup Under Deck	x							66
Clean GHS Exhaust Screen*	x							67
Clean GHS Blower*	x							66
Service Mower Blades	x							69
Check Functions of Instrument Panel and Warning Horn	x							27
Lubricate Grease Fittings and Oil Points*		x						59
Check PTO Gearbox Oil Level**		x						58
Check Battery Electrolyte Level		x						68
Check Hydrostatic Transmission Fluid		x						59
Check Tire Pressure		x						69
Check Drive Belts (Jackshaft, Engine PTO, GHS Blower, Ground Drive)		x						70
Check Deck Gearbox Oil Seals		x						71
Check Safety Switch System		x						72
Check Turbine Precleaner*			x					62
Check Blade Brake Action			x					71
Check/Clean Air Filter Element***			x					63
Check Oil Level in Gear Axle			x					58
Clean Hydrostatic Transmission Cooling Fins			x					67
Clean Engine Cooling Fins			x					65
Check Wheel Bolt Torque (75 to 85 lb·ft)			x					69
Check/Regap Spark Plugs				x				71
Change Engine Crankcase Oil Δ					x			56
Change Engine Oil Filter $\Delta\Delta$					x			56
Replace Air Filter Element, Safety Filter, Dust Ejection Valve***						x		63
Replace Fuel Filter						x		78
Service Battery						x		68
Check Transmission Control Settings						x		71
Check FSC Friction Lock						x		72
Service Solenoid Shift Starter						x		\diamond
Check PTO U-Joints for Wear/Looseness						x		72
Check Fuel Lines and Clamps						x		71
Remove Engine Shroud and Clean Cylinder Head Cooling Fins						x		65
Change Gear Axle Oil $\Delta\Delta\Delta$							x	58
Change Hydrostatic Transmission Fluid $\Delta\Delta\Delta$							x	\diamond
Replace Fuel Lines and Clamps							x	71
Replace Ignition Wires							x	71

- * More often in extremely dusty or dirty conditions (refer to notes about air cleaner element in IMPORTANT TIPS FOR CARE OF THE KOHLER ENGINE)
- ** Change PTO gearbox oil after first 100 hours of operation (break-in period)
- *** Air cleaner is remote mounted Donaldson Radialseal™ unit, replace filters every year and dust ejection valve every year or when worn or damaged
- Δ Factory service uses Kohler PRO® oil. If conventional oil is used for oil changes instead of the Kohler PRO®, the oil must be changed every 100 hours.
- $\Delta\Delta$ Factory service uses a Kohler PRO® filter. If a conventional Kohler filter is used for oil changes instead of the Kohler PRO® version, the filter must be changed every 200 hours.
- $\Delta\Delta\Delta$ Change every 2 years or 1000 hours
- \diamond See your Walker dealer for this service or refer to the Walker Service Manual

IMPORTANT TIPS FOR CARE OF THE KOHLER ENGINE

Fuel System

- Fuel must be clean - free from water, dirt, and organic material.
- Change fuel filter on a regular basis and when contamination is suspected or found in the fuel.
- The fuel injection system is pressurized. Do not attempt to service this fuel system. Contact your Walker dealer or authorized Kohler service dealer for work on the fuel system.

Starting/Stopping

- Start engine with the throttle advanced off idle (1/4 to 1/2 throttle). This will aid starting, especially in cold weather.
- Keep the battery fully charged.
- Match crankcase oil viscosity to the ambient temperature, allowing the engine to crank faster and start easier.
- Allow engine to run at idle for a few seconds before stopping engine to avoid run-on or back-firing.

Cooling System

CAUTION

DO NOT use water or a pressure washer to clean the cooling system on an air-cooled engine; mud may form under the cooling shroud on the cylinder head and cooling fan resulting in engine overheating.

- Keep engine air intake screen and cylinder head fins free of grass clippings, chaff, and dirt. Inspect intake screen and cooling fins for cleanliness and no damage.
- Periodically remove two access panels in the engine shroud to inspect and clean cylinder head cooling fins.
- Check performance of the cooling system by starting the engine, holding a hand adjacent to the cylinder head, and feeling the cooling air-flow.

DANGER

Make sure to keep hands clear of exhaust pipe, muffler, and moving parts when checking airflow.

- Operate the engine at full speed when mowing. This allows the engine to produce full horsepower and move more cooling air through the engine cooling fins.

Air Cleaner System

- Use **only** Donaldson air cleaner elements. Aftermarket elements may not seal in the air cleaner housing, allowing dirt to enter the engine. Also, aftermarket filters often skimp on the filtration media and require more frequent replacement (see following instructions).
 - Use the air filter restriction gauge to indicate the need to service the air filter.
 - Do frequently check the **Turbine Precleaner** for free movement of the internal fan.
 - **DO NOT overservice or frequently “disturb” the air filter.** A dirty air filter actually cleans better than a new one. Changing and cleaning the air filter too often can actually reduce filter efficiency and increase the opportunity for traces of dust to enter the engine. Wait until the element really needs servicing as indicated by the air filter restriction gauge.
 - When the air filter element is removed or replaced, make sure all **dust is cleaned out** of the **air cleaner housing and hose**. Use a damp cloth and wipe the interior of the canister and hose clean (a little dirt left here will be sucked into the engine and reduce engine life). When the filter is reinstalled, make sure the **element is held tight and straight** in the canister for proper seating and sealing.
 - Periodically check the air intake hose for cuts, nicks, etc., and the hose clamps for tightness.
- ### Oil
- Use only multi-viscosity oils as specified with the viscosity matching ambient temperatures for the engine operating conditions. This will **aid starting** in cold weather and assure proper lubrication in hot weather.

- Use only Kohler oil filters. **Aftermarket filters may not seal properly** and/or have the incorrect pressure relief valve for proper lubrication.

LUBRICATION



WARNING

DO NOT attempt to lubricate the machine with the engine running. Disengage the PTO clutch, shut off the machine, and remove the ignition key.

Proper lubrication is an important maintenance procedure. It reduces wear and makes the machine quieter and easier to operate.

Engine Oil

Engine Break-In Oil

The engine is serviced with Kohler PRO® 10W-50 synthetic oil and a Kohler PRO® filter from the factory. Both are rated for 300 hour oil change intervals. A break-in engine oil change is not required. The engine crankcase oil and the filter must be changed **after every 300 hours** of operation.

NOTE: Kohler PRO® oil and filter are not required, but recommended. If conventional oil and filters are used in the tractor, the oil must be changed **after every 100 hours** of operation, and the filter must be changed **after every 200 hours**. See the **Specifications** section for details on which oil and filters are recommended.

Checking Engine Crankcase Oil Level

Check the engine crankcase oil level before use and **after each 8 hours** of continuous operation.

IMPORTANT: The importance of checking and maintaining the proper crankcase oil level cannot be overemphasized. Check the oil level **BEFORE EACH USE**.

1. Park the mower on a **level surface with the engine stopped**. Also, make sure the engine is cool and oil has had time to drain into the sump [allow **at least five (5) minutes** after stopping the engine].

IMPORTANT: NEVER check or add oil with the engine running.

2. Before removing the dipstick, clean the area around the dipstick to keep any dirt or debris out of the engine.
3. Remove the dipstick, wipe off with a clean rag, then reinsert the dipstick into the tube and press all the way down.
4. Remove the dipstick again and check the oil level on the dipstick. The oil level should be within the "Operating Range" on the dipstick (between the "L" mark and the "F" mark).

IMPORTANT: DO NOT operate engine without a sufficient oil supply in the crankcase. **DO NOT** operate with the oil level below the "L" mark or above the "F" mark on the dipstick.

5. If additional oil is needed, refer to **Specifications** for proper crankcase lubricant. **Fill up to, but not above, the "F" mark on the dipstick.**

IMPORTANT: DO NOT overfill the crankcase (oil above "F" mark) as this **CAN** result in engine overheating, loss of power, and possible engine damage.

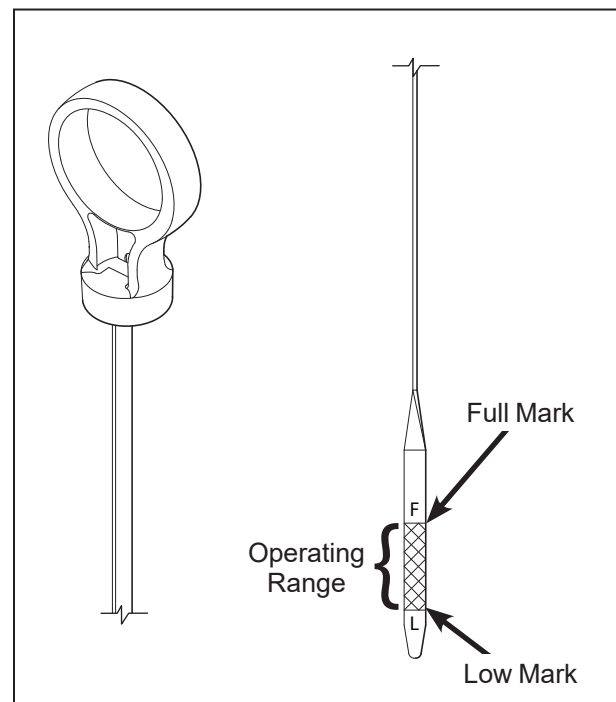

Dipstick Operating Range

Changing Engine Crankcase Oil/Oil Filter

Change the engine crankcase oil and filter **every 300 hours** if the recommended Kohler PRO® products are being used. If conventional oil and filters are being used, change the crankcase oil **after every 100 hours** of operation and replace the oil filter **after 200 hours** of operation.

1. Park the mower on a **level surface with the engine stopped**. The engine oil should be warm before draining. If not warm from operation, start the engine and run a few minutes to warm the oil.
2. Before removing the dipstick, clean the area around the dipstick to keep any dirt or debris out of the engine.
3. Remove the dipstick and the oil drain plug and drain the oil into a suitable container. Be sure to allow ample time for complete drainage.

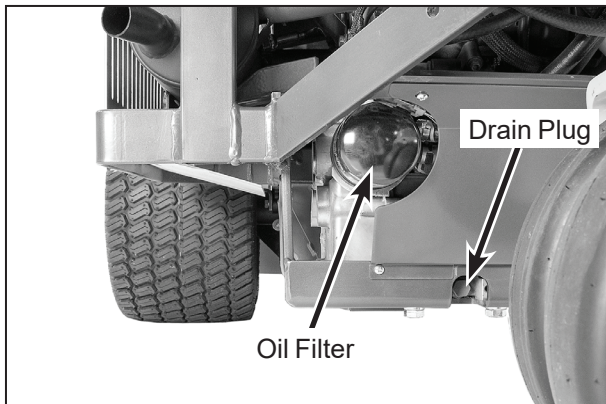

Oil Drain/Oil Filter Location

4. Before removing the oil filter, clean the area around the filter to keep dirt and debris out of the engine.
 5. Remove the old oil filter and wipe off the filter mounting surface on the engine.
 6. Apply a thin coating of clean oil to the rubber gasket on the replacement oil filter.
- IMPORTANT:** Use **ONLY** Kohler oil filters. See the **Specifications** section for a list of recommended filters. Aftermarket oil filters may not seal properly and/or may not have the correct pressure relief valve for proper lubrication.
7. Install the new oil filter on the engine. Turn the filter clockwise until the rubber gasket contacts the sealing surface, then tighten an additional **3/4 to 1 turn**.

8. Reinstall the drain plug. Make sure it is tightened to 10 lb·ft (14 N·m).
9. Remove the fill cap on the engine valve cover, and fill the crankcase with new, clean oil. Use only crankcase lubricants recommended by the engine manufacturer. Refer to **Specifications** in this manual or the engine owner's manual. Use the recommended oil viscosity for the expected ambient temperature. Oil with the correct viscosity will aid starting in cold weather and assure proper lubrication in hot weather. **Fill up to, but not above, the "F" mark** on the dipstick. Crankcase capacity is 2.0 quarts (1.9 liters) plus 1/2 pint (0.24 liters) for the new oil filter.

IMPORTANT: Check the dipstick reading before adding the last 1/2 pint of oil and **fill only to the "F" mark**. **DO NOT** overfill the crankcase (oil above "F" mark) as this **CAN** result in engine overheating, loss of power, and possible engine damage.

10. Start the engine and check for oil leaks around the oil filter. Stop the engine, recheck the oil level, and add oil if necessary. (When the engine is first operated with a new oil filter, the oil level drops slightly as the filter is filled with oil.)

Mower Deck Gearbox Lubrication

NOTE: These instructions apply to all mower decks with gear-driven blades. Refer to **DS52 or DS62 Mower Deck Lubrication** in this section for the DS52 or DS62 deck with belt-driven blades. Refer to **Mower Deck Spindle Lubrication** in this section for the DS42 Belt Drive deck with belt driven blades.

On gear driven decks, the mower deck gearboxes (tee gearbox and blade drive gearboxes) are connected as a unitized assembly, and oil flows freely between them. The gearboxes are permanently lubricated (oil filled) and sealed requiring no scheduled lubrication. However, the gearbox oil seals should be checked **every 25 hours** for indication of an oil leak; **particularly the lower seals** on the blade drive gearboxes should be inspected, since they operate in a dirty environment. If an oil leak is noted, replace the oil seal and relubricate the gearbox assembly as follows:

1. Remove gearbox cover (footrest). Deck orientation should be the normal operating position.

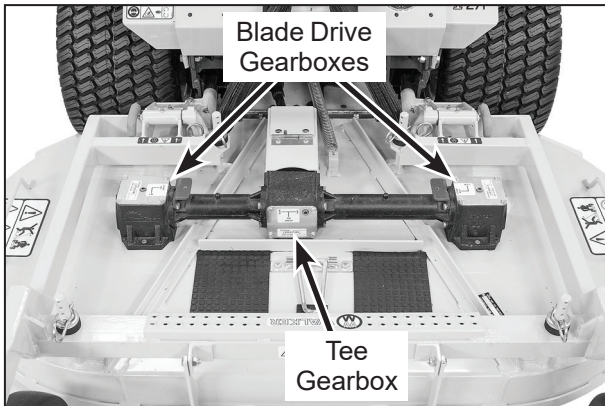

**Mower Deck Gearboxes
(Shown with Gearbox Cover
Removed for Clarity)**

2. Clean the area around the individual gearbox cover plates to prevent contaminants from entering the gearcase.
3. Remove the screws securing the cover plates on the blade drive gearboxes.
4. Check the level of lubricant in the gearboxes. If the lubricant is low, add SAE E.P. (Extreme Pressure) 80W-90 (API GL-5) gear lube until the oil level is up to (submerges) the horizontal shaft in the gearbox (shaft parallel to cover plate).

NOTE: In case the gearboxes are completely drained of oil, approximately 5 fl. oz. (15 cl) of oil per gearbox is required to refill the gear drive assembly.

NOTE: Since the gearboxes are connected as a unit by connector tubes, it is necessary to add oil slowly. Allow a few minutes after adding oil for the oil to flow throughout the assembly and the oil level to stabilize before reassembly.

IMPORTANT: **DO NOT** overfill the deck gearboxes. The gearbox assembly is not vented, and overfilling with oil will cause excessive pressure and result in oil leaks.

5. Check condition of the cover gasket and replace if worn or damaged. Reinstall gearbox cover plates; torque screws to 24 lb·in. (3 N·m).

DS52 or DS62 Mower Deck Lubrication

There are several special lubrication requirements for the DS52 or DS62 mower deck in addition to the requirements detailed in the **Chassis and Deck Lubrication Points** illustration. Lubricate the locations shown in the **Gearbox, Dolly Wheel, and U-Joint Lubrication** photo and check and maintain oil in the belt drive gearbox.

1. Check the oil level in the belt drive gearbox **every 100 hours** (or sooner if a visible oil leak has developed). With the deck in the normal operating position, remove the level plug in the side of the gearcase. Add SAE E.P. (Extreme Pressure) 80W-90 (API GL-5) gear lube to maintain the oil level to the plug. If the oil level is low, check the gearbox for any indication of an oil leak. If an oil leak is noted, the gearbox will need to be removed and rebuilt.
2. Lubricate the dolly wheel pivot **every 25 hours** with general purpose grease.
3. Lubricate both drive shaft u-joints **every 25 hours** with SAE general purpose lithium or molybdenum base grease.

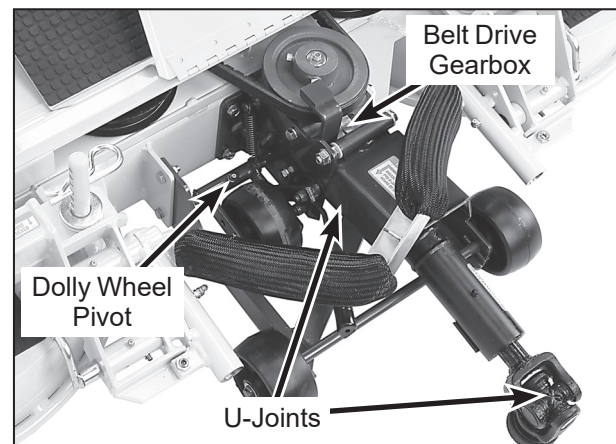

Gearbox, Dolly Wheel, and U-Joint Lubrication

Mower Deck Spindle Lubrication

For the DS42 Belt Drive mower deck, lubricate each deck spindle grease fitting **every 25 hours**. Use SAE general purpose lithium or molybdenum base grease for grease fittings.

Tractor PTO Gearbox Lubrication

Checking Gearbox Oil Level

Check the gearbox oil level **every 25 hours**, and if necessary, add oil [SAE E.P. (Extreme Pressure) 80W-90 (API GL-5) gear lube] to maintain oil level to the **FULL** mark on the dipstick.

IMPORTANT: DO NOT overfill the PTO gearbox to avoid oil leakage out of the dipstick standpipe.

If the oil level is low, check the gearbox for any indication of an oil leak. If an oil leak is noted, the gearbox will need to be removed and rebuilt.

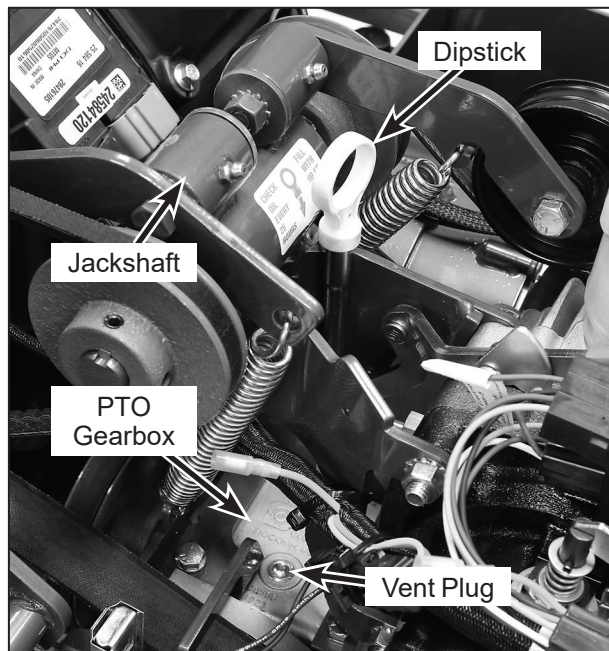

Dipstick Location, Tractor PTO Gearbox

Changing Gearbox Oil

The tractor PTO gearbox is oil filled. No scheduled oil change is required. However, changing the oil **after the first 100 hour break-in period** will extend gearbox life and is recommended.

1. Remove the drain plug in the bottom of the gearcase, drain the oil, and reinstall the plug.
2. Refill the gearbox through the dipstick standpipe using 7 to 8 fl. oz. (21 to 24 cl) of SAE E.P. (Extreme Pressure) 80W-90 (API GL-5) gear lube. Remove plug in top of gearcase to vent air when refilling.
3. Check that the oil level is at the **FULL** mark on the dipstick. **DO NOT** overfill.

Gear Axle Lubrication

- The gear axle oil lubrication is SAE E.P. 80W-90 (API GL-5) gear lube.
- Check the axle oil level **after every 100 hours** of operation by removing the oil level plug. If additional oil is needed, remove the breather vent on top of axle and fill until oil is at the level plug.
- Change axle oil **every 1000 hours** or **two (2) years**.

Hydrostatic Transmission Fluid

Checking Hydrostatic Transmission Fluid Level

The hydrostatic transmissions are sealed units and do not need to be opened to check the fluid level. Hydrostatic fluid level should be checked **every 25 hours** of machine operation. It is preferable to **check the fluid when the fluid is cold**. Check fluid levels as follows:

1. Park the mower on a **level surface**. Stop the engine and wipe dirt and contaminants from around the base of the reservoir to better see the **COLD** mark.
2. The level of the oil can be seen through the side of the opaque reservoir (**DO NOT REMOVE RESERVOIR CAP**); using a light next to the reservoir will help make the level more visible.

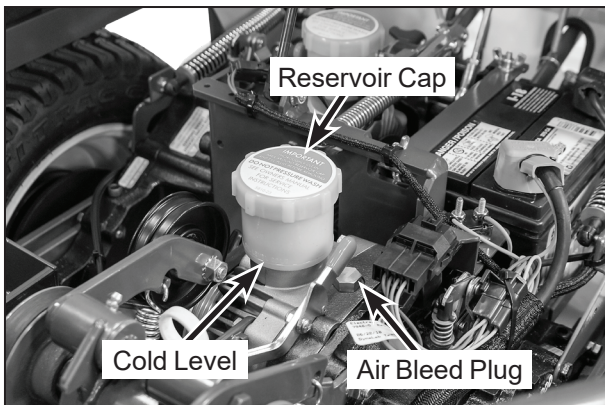

Transmission Reservoir and Air Bleed Plug Location

3. The reservoir has a fluid level **COLD** mark. The reservoir oil level should **ALWAYS** be at or slightly above the **COLD** mark.
4. If the fluid is below the **COLD** mark (or the transmission is not performing properly), **contact your local dealer**. **Attempting to add fluid or service the transmission may VOID THE TRANSMISSION WARRANTY.**

NOTE: Loosening the air bleed plug on top of the transmission can be used to verify a low oil condition in the transmission. As the plug is loosened (**DO NOT** completely remove plug), oil will seep out if the transmission is full of oil. If no oil appears, the transmission oil level is low and the transmission will need to be serviced by an authorized Walker dealer. When a transmission is found to be low on oil, it is highly probable that has been caused by an oil leak either on the input drive shaft or the control arm pivot. Dealer service is required to correct any oil leak along with refilling the transmission oil to the proper level.

Grease Fitting and Oil Point Lubrication

Lubricate the grease fittings and oil points **after every 25 hours** of operation. Lubricate **more often** when operating in **dusty or dirty conditions**. Use SAE general purpose lithium or molybdenum base grease for grease fittings and light machine oil (SAE 10) to lubricate oil points. **Lubricate the locations shown in the Chassis and Deck Lubrication Points illustration.**

NOTE: PTO universal joints (on the deck and tractor) require routine lubrication **after every 25 hours** of running time. Remove tractor PTO quick disconnect tube assembly for easy access to grease fittings.

NOTE: The best way to lubricate the PTO tube half of the universal joint assembly is to remove it from the tractor. See instructions for removing and installing PTO quick coupler, refer to *Deck Installation in Mower Deck Installation on Tractor* in the *Assembly Instructions*.

Ident No.	Location	Lubrication Type	No. Places
1	Deck Caster Wheel Fork Pivot	Grease	2
2	Deck Caster Wheel Bearing	Grease	2
3	Blade Spindle	Grease ^Δ	3
4	Pivot Assembly, Tilt-Up Deck	Grease	4
5	Deck Support Arm Socket	Grease	2
6	Right Angle Gearbox	Oil* ^Δ	1
7	Universal Joint Shaft Assembly	Grease**	1(2 ^Δ)
8	Dolly Wheel Retract Lever and Linkage	Oil ^Δ	1
9	Dolly Wheel Pivot	Grease ^Δ	1
10	Idler Arm Pivot	Grease ^Δ	1
11	Tee Gearbox, Deck	Oil*	1
12	Blade Drive Gearbox	Oil*	2
13	Steering Lever Pivot	Grease	4
14	Body Hinge Point	Oil	2
15	Deck-to-PTO Coupling (Grease Spline Slide Area)	Grease	1
16	(FSC) Friction Body Pivot	Grease	1
17	FSC Actuator Rod Pivot Pins	Oil	2
18	FSC Lever Pivot	Grease	1
19	Deck Support Arm Pivot	Grease	2
20	Gear Axle	Oil***	2
21	Universal Joint Tube Assembly	Grease**	1
22	Parking Brake Lever	Grease	1
23	Belt Tightener Pivot, Jackshaft Drive	Grease	1
24	PTO Clutch Lever Pivot	Grease	1
25	Clutch Actuator Push Rod	Grease	2
26	Belt Tightener Pivot, PTO Clutch	Grease	1

Ident No.	Location	Lubrication Type	No. Places
27	Brake Actuator Rod and Brake Band Pivots (Clevis)	Oil	3
28	Throttle Control Cable Ends	Oil	2
29	Brake Actuator Pivot	Grease	1
30	Catcher Hinge Point	Oil	2
31	Rear Wheel Bearing	Grease	2
32	Engine Dipstick / Oil Filler	Oil***	1
33	Belt Tightener Pivot, Blower Drive (GHS Model Only)	Grease	1
34	Belt Tightener Pivot, Ground Drive	Grease	1
35	PTO Gearbox Dipstick	Oil***	1
36	Hydrostatic Drive	Oil***	2
37	Universal Joint Quick Connect Spline (Grease Slide Area)	Grease	1
38	Throttle Control Pivot	Oil	1

* Gearboxes are permanently lubricated and sealed requiring no scheduled lubrication. Oil level should be checked only when an oil leak is noted. Refer to **Mower Deck Gearbox Lubrication** in this section.

** Grease every twenty-five (25) hours.

*** Refer to **Gear Axle Lubrication, Engine Oil, Tractor PTO Gearbox Lubrication, and Hydrostatic Transmission Fluid** in this section.

Δ Belt Driven Decks Only

NOTE: DC48 and DS62 Tilt-Up Decks are shown for reference. For other Deck Lubrication Points, Refer to **Deck and Carrier Frame Illustrated Parts Manual**.

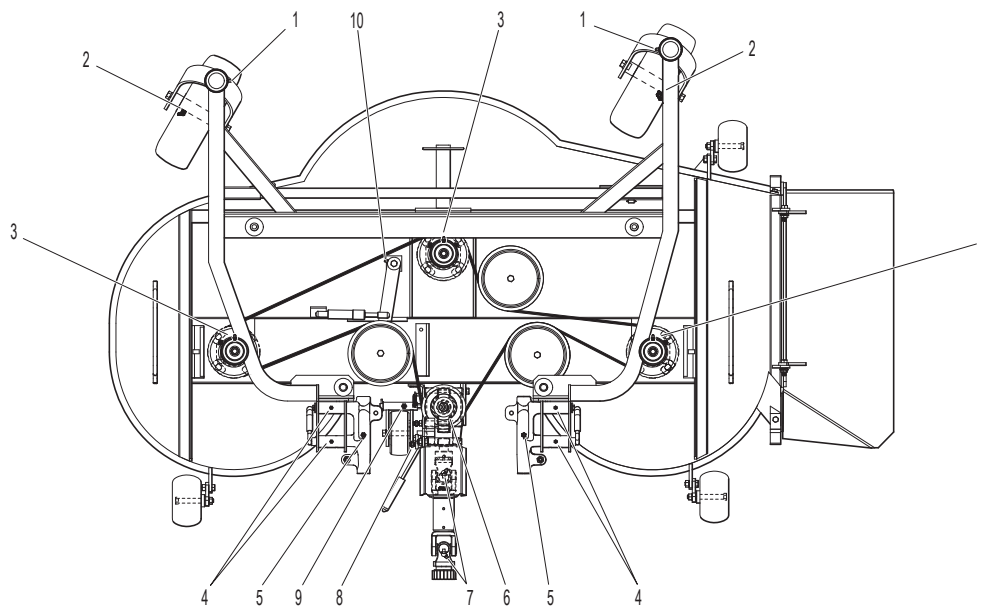

Lubrication Points for Optional Belt Driven Decks (DS62 Shown)

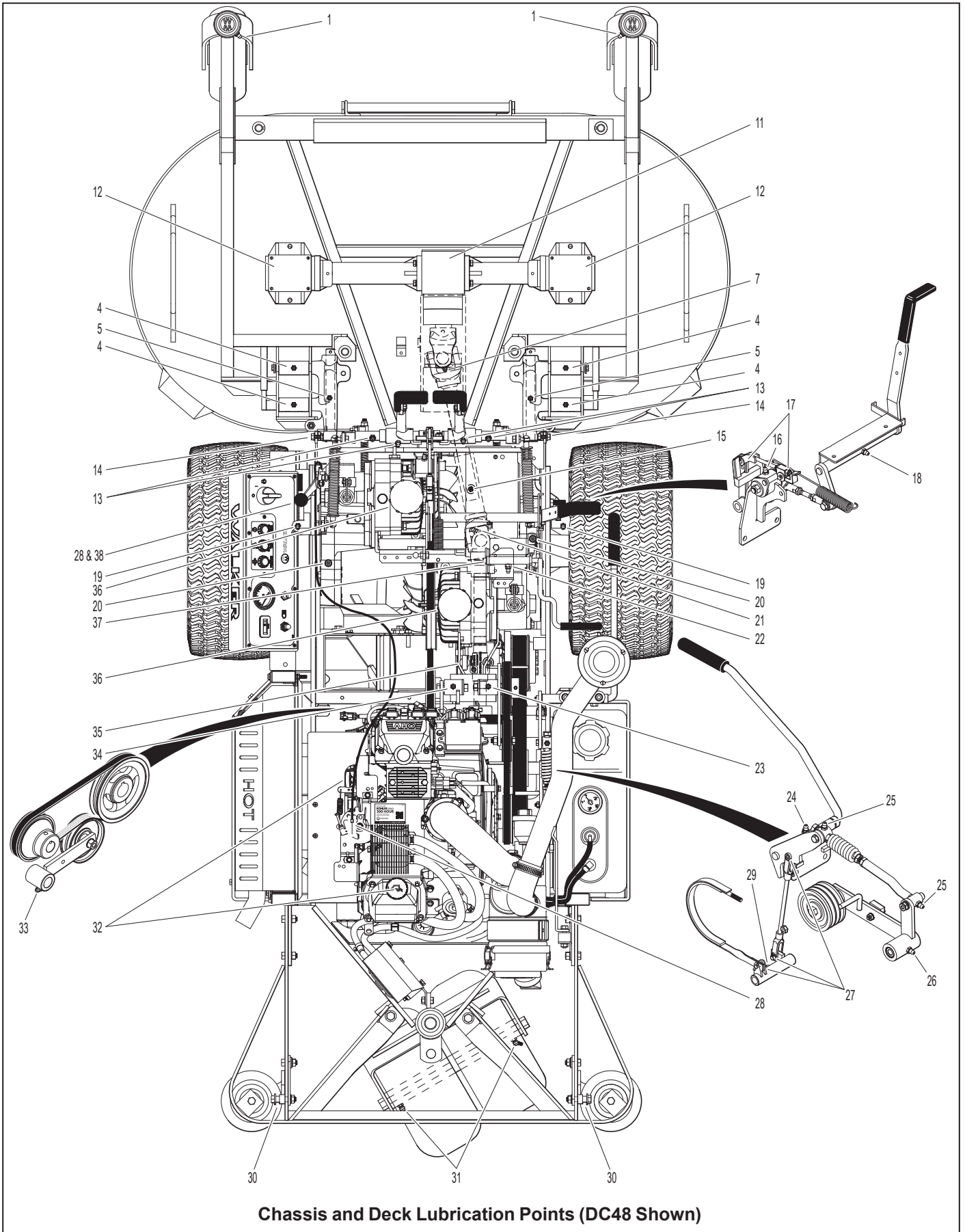

Chassis and Deck Lubrication Points (DC48 Shown)

CLEANING

CAUTION

If a pressure washer is used on the exposed working parts, avoid water on the electric parts and the engine cooling system.

Engine Air Cleaner System

There are two main components in the engine air cleaner system: a turbine precleaner and a Donaldson Radialseal™ air cleaner. Each component is checked, cleaned and maintained on a different schedule based on the filtering action required. Each component is serviced as follows:

Turbine Precleaner

The turbine precleaner is mounted on a remote air intake tube connected to the Donaldson air cleaner. A spinning fan driven by the intake airflow separates dust from the air, giving the initial stage of air cleaning. Dust particles are exhausted through a single small vent in the side of the housing. Since no dust is trapped, the precleaner operates without cleaning. The only maintenance required is to check the operation of the internal fan **every 100 hours**. Verify operation:

1. Look into the exhaust vent while shining a light into the intake.
2. Start the engine and watch the fan begin to spin as the throttle is advanced.

If the fan is not spinning, service or replace the pre-cleaner as required.

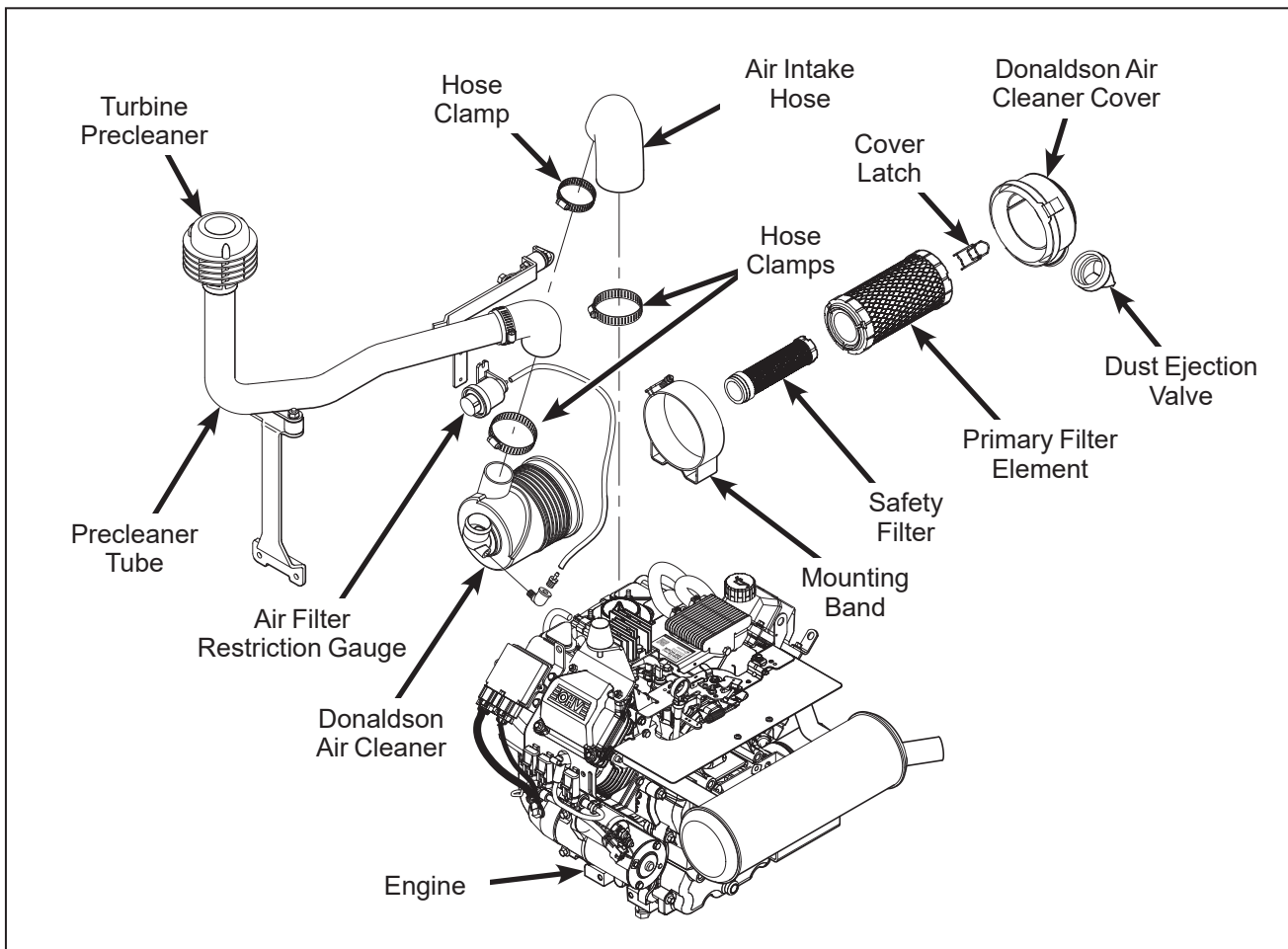

Engine Air Cleaner System Components

Donaldson Radialseal™ Air Cleaner

A remote mounted Donaldson Radialseal™ air cleaner provides the air filtering function. The paper filter element slides over an outlet tube inside the air cleaner canister with **radial** sealing action, reducing the possibility of dust leaks due to improper filter installation. Intake design, internal baffling, and a dust ejection valve provide dust separation and automatic precleaning action. Daily or frequent servicing of the air cleaner **is not required**. Use the air filter restriction gauge on the air cleaner outlet to indicate when the air filter needs servicing—a yellow indicator will show when the filter is overly restricting airflow into the engine.

IMPORTANT: Use **only** Donaldson air filter elements for replacement (Donaldson P822686 or Walker 5090-1). Aftermarket filters may not seal properly or filter efficiently.

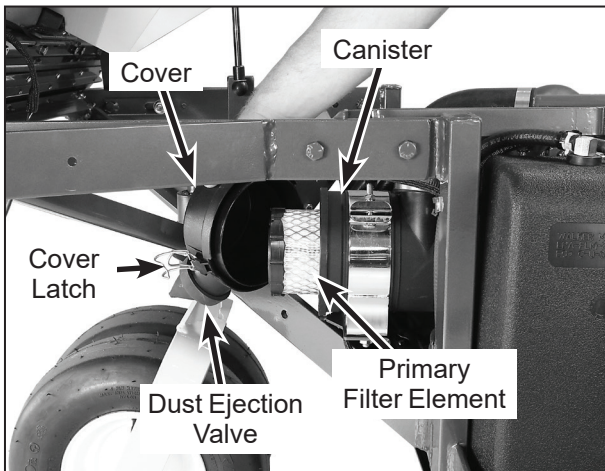

**Air Cleaner Components
(Shown with Cover Being Removed)**

IMPORTANT: The Donaldson air cleaner uses a dry paper-type air filter element. **NEVER** apply oil to the paper element.

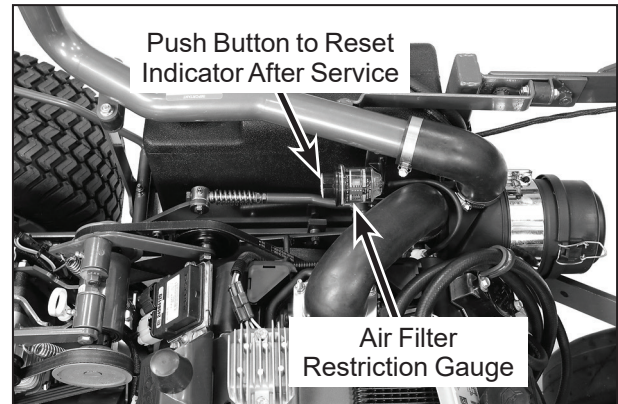

Air Filter Restriction Gauge Location

Inspect the paper element **after every 100 hours** of service and **replace** the element and safety filter **yearly** (or when dirty or damaged). More frequent replacement may be required when operating in extremely dusty conditions as indicated by the air filter restriction gauge. Service the air cleaner as follows:

1. Release the top and bottom cover latches and remove the air cleaner cover. Wash the cover and dust ejection valve. Check that these components are in good condition. The dust ejection valve is subject to wear and deterioration and should be inspected carefully and replaced **yearly** or when damaged. The lips of the valve should close and fit together; any cracks, deformation, or wear in the valve is cause for replacement.
2. Remove the filter element by pulling it out of the canister. There will be some initial resistance as the filter seal breaks loose and slides off of the outlet tube. **Gently** move the end of the filter up and down and side to side or twist to loosen the seal. Use gentle action to minimize the amount of dust dislodged as the filter is removed.
3. Discard the filter element if excessive air flow restriction has been indicated by the air filter restriction gauge and proceed to Step 6. Clean the filter element by **gently tapping** on a **flat, hard surface**. If excessive restriction still exists after cleaning the element, it should be replaced.

NOTE: Use care when cleaning the filter element. The filter element and/or seal surface may be damaged by tapping too hard or hitting on an uneven surface or sharp edge. Washing the paper element in water or cleaning solution is **not recommended**. Do not try to clean the element with compressed air. Do not oil the paper element. Remember replacing a filter is less expensive than replacing a dusted engine.

4. Use a bright light inside the element to inspect for damage. Check the element very carefully for **pin holes or other damage** that will allow dirt to leak through the paper media. Replace filter element if dirty or damaged.
5. Check the condition and resilience of the radial sealing surface (inside of the open end) of the filter. Replace the filter if any cracks, tears, or other damage to the sealing surface are noted.
6. Without removing, visually inspect the condition of the safety filter for damage or holes. The safety filter should only be removed for **yearly replacement** (or when dirty or damaged).

IMPORTANT: Prior to removing the safety filter, make sure the inside surface of the air cleaner canister is clean. This will minimize the risk of dirt entering the outlet tube which can cause premature engine wear.

7. After removing the safety filter, use a clean, damp cloth and wipe the interior of the air cleaner canister clean. Use special care to clean **both the inside and outside** surfaces of the outlet tube.

IMPORTANT: Any dust left on the inside of the outlet tube will go into the engine and cause wear.

8. Check the outside surface of the outlet tube for smoothness and cleanness (this is the sealing surface).
9. Insert and seat the safety filter and primary filter element carefully into the canister, applying pressure at the outer rim of the filter; not at the flexible center. Make sure the filter element is completely in place before installing the cover.

IMPORTANT: **DO NOT** use the **cover latches** to force the filter into the canister—the cover should fit on with **no extra force**.

NOTE: **DO NOT** use petroleum based lubricants on the sealing surfaces of the filter; use talcum powder or dry silicone lubricants if required for filter installation.

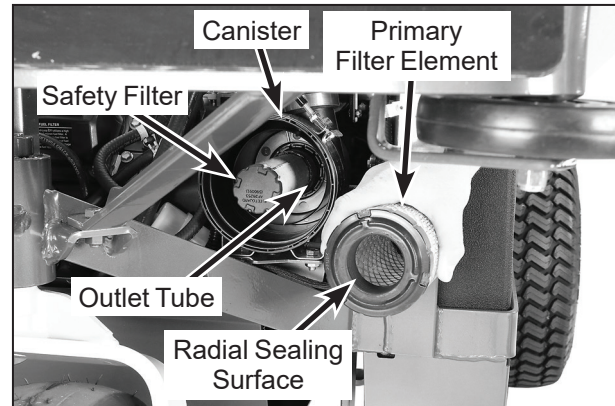

Air Filter Element Replacement

10. Install the cover with the word “TOP” properly oriented to the top of the canister. Give the cover a slight twist as it reaches the canister to make sure the tab inside the cover goes into a slot, otherwise the cover will not fit properly. Make sure both the top and bottom cover latches are securing the cover in place.

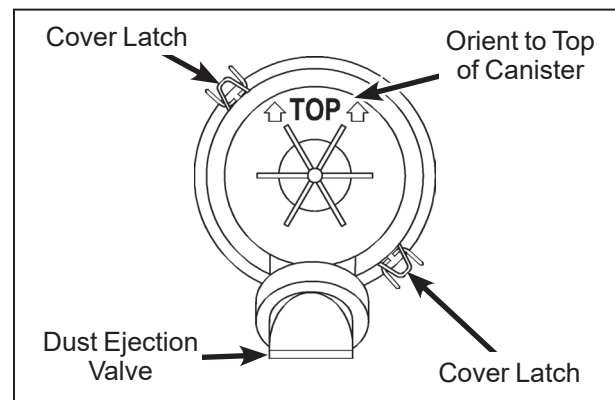

Proper Orientation of Air Cleaner Cover

11. Check the air intake hose for cuts, nicks, cracks, etc., and the hose clamps for tightness.
12. Reset the air filter restriction gauge (press button on the end of the indicator).

Engine Cooling System

Cooling Air Intake Screen

To prevent engine overheating and possible engine damage, clean grass clippings, chaff, and dirt from the rotating engine cooling air intake screen **after every 8 hours of operation**. In certain mowing conditions (dry grass, leaves, tree "cotton", etc.), it may be necessary to check and clean the screen several times each day to prevent engine overheating. Also, visually check inside cylinder head shroud and between cylinder head fins for material packed in this area which would prevent cooling airflow; remove shroud and clean as required.

CAUTION

Operating the engine with a blocked air intake screen, dirty or plugged cooling fins, and/or cooling shrouds removed will cause engine damage from overheating.

Cylinder Head Cooling Fins

It is essential for performance and longevity of the air-cooled engine to keep the cylinder head cooling fins clean and free of obstruction. After **every 8 hours** of operation, check the performance of the cooling system by starting the engine, holding a hand adjacent to the cylinder head, and feeling the cooling airflow. If there is little or no airflow, clean the cooling fins as follows:

DANGER

Make sure to keep hands clear of exhaust pipe, muffler, and moving parts when checking airflow.

Every 100 hours, inspect and clean the cooling fins (more often when operating in extremely dusty, dirty conditions). Remove the two (2) cooling fin access panels in the engine shroud and clean the cooling fins and external surfaces using compressed air. Make sure to reinstall the access panels before operating the engine.

CAUTION

DO NOT use a pressure washer to clean the cooling system on an air-cooled engine, mud may form under the cooling shroud on the cylinder head and cooling fan.

NOTE: If dirt is packed into the cooling fins it may be necessary to remove the engine shroud in order to thoroughly clean the cooling fins.

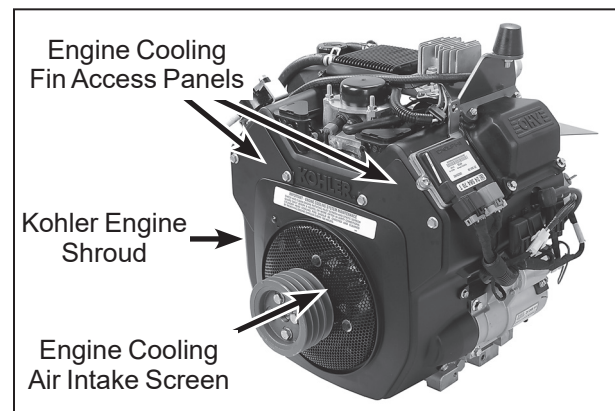

Keep Rotating Cooling Air Intake Screen and Cooling Fins Clean

IMPORTANT: Yearly, it is good maintenance practice to remove the engine cooling shroud and clean the cylinder head cooling fins thoroughly to prevent overheating and extend engine life. Make sure cooling shroud is reinstalled properly. This procedure will require removing the engine from the chassis.

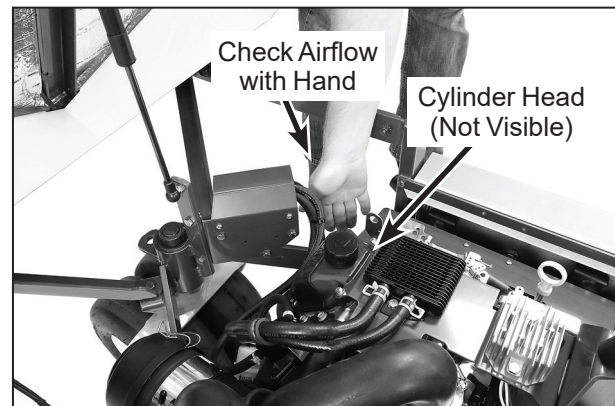

Check Cooling System Airflow

Grass Buildup in Mower Deck Housing

DANGER

Before raising or removing the mower deck for cleaning, stop the engine, remove the ignition key, and disconnect the spark plug wires.

1. Raise the deck lock lever handle on each side of the carrier frame and pull out to release carrier frame for tilting action.
2. Using the carrier frame lift handle, raise deck to the **TILT-UP** position and insert the deck hook into the tilt-up latch on the tractor body.

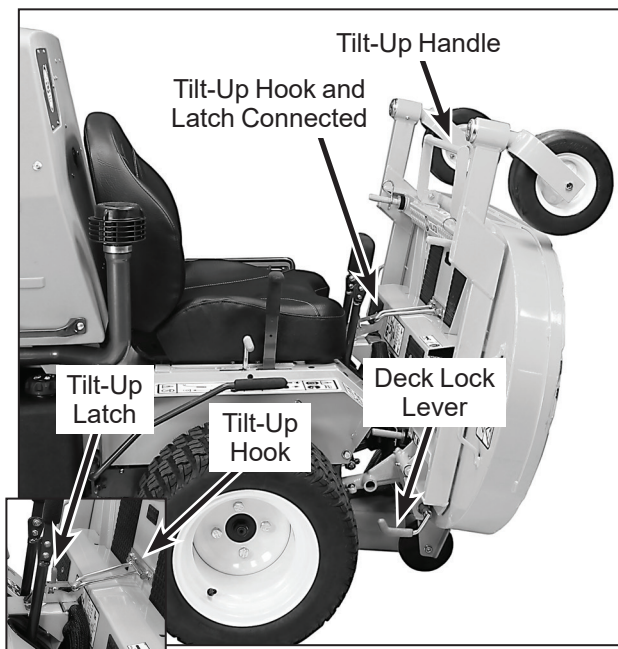

Deck Secured in TILT-UP Position

DANGER

Do not operate the mower with deck in tilt-up position. Do not move the tractor with the deck in the tilt-up position.

3. Clean grass buildup underneath the deck using a pressure washer (and scraper if required).

NOTE: While some degree of material buildup in the mower deck housing can be tolerated, a point is finally reached **where cutting quality deteriorates and clogging begins to occur** because of too much buildup on the baffling and housing.

4. Lower the deck to the normal operating position and re-engage the deck lock levers.

CAUTION

Do not operate machine with deck tilt-up pivot joint unlocked.

GHS Blower

Normally, the GHS blower operates with no maintenance or cleaning. However, when mowing **grass that is dirty and damp** (especially certain spring-time mowing conditions), a deposit of dirt may accumulate inside the blower housing, causing wear and binding of the blower wheel. When operating in these conditions, **inspect the blower frequently for dirt buildup.**

NOTE: A visual clue of binding of the blower wheel is the blower **blade tips are polished** from rubbing on dirt.

When a dirt deposit is found, use a high pressure washer or water spray to clean the inside of the housing as follows:

DANGER

Before attempting to wash the blower, stop the engine, remove the ignition key, and disconnect the spark plug wires. Wear goggles or face shield.

1. Remove the GHS blower drive belt tension by depressing the idler pulley on the tightener arm. Roll the belt off the blower pulley. The belt should be clear of the blower pulley, allowing **free movement** of the blower wheel.

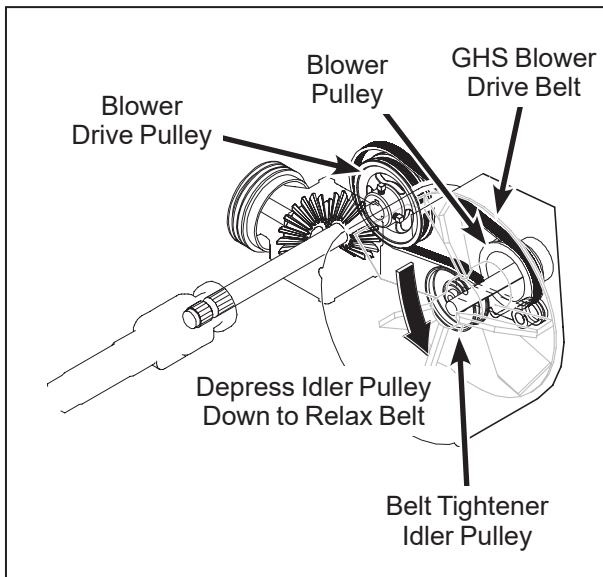

Collapse Blower Belt Tightener to Remove GHS Blower Drive Belt

IMPORTANT: With the belt removed, the blower wheel **must spin freely**. Any binding or dragging of the wheel is an indication of dirt build-up. This **buildup must be cleaned** to avoid abrasive wear of the blower blades, excessive power loss and eventual loss of blower performance (clogging).

2. Use a pressure washer or water spray, and direct the spray inside the blower housing against the blower blades. Water pressure will cause the blower wheel to begin to spin and the combination of spinning action and water will effectively wash the inside of the housing. Spray may be directed against the blower blades vertically and horizontally to cause rotation in both directions for thorough washing action. **Wash blower until the blower wheel spins freely** in both directions.
3. Reinstall the GHS blower drive belt by reversing the removal procedure.

GHS Exhaust Screen

Refer to **Cleaning the GHS Exhaust Screen** in **Operating Instructions**.

Hydrostatic Transmission Cooling Fins

Keeping the cooling fins on the hydrostatic transmissions clean and free of obstruction is **essential to avoid overheating** the transmission fluid and shortening transmission life. The cooling fins should be checked **every 100 hours** and cleaned if necessary.

To clean the fins, use compressed air and/or a pressure washer. The cooling fins extend all the way around the housing—the fins underneath need to be clean as well as the more visible fins above. Also, pay close attention to the area under the drive pulley.

IMPORTANT: In case an oil leak develops on the input shaft, the cooling fan blowing dusty air and oil on the transmission will **quickly** pack the cooling fins with **oily dirt**. If this condition occurs, replace the seal immediately to avoid overheating and damaging the transmission. The input shaft assembly and seal are easily replaced without removing the transmission from the machine.

An additional procedure in maintaining transmission cooling is to inspect the cooling fans. Replace the fan(s) if blades are missing or damaged.

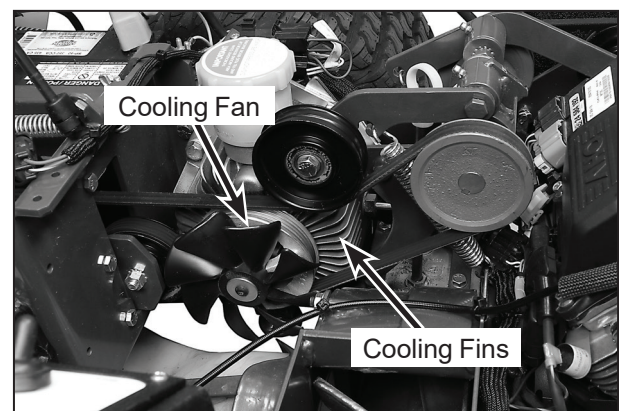

Hydrostatic Transmission Cooling Fins

CHECKING/SERVICING

DANGER

To prevent accidental starting of the engine when servicing or adjusting the machine, remove the key from the ignition switch and disconnect the spark plug wires.

Security of Air Filtration Components

NOTE: The following inspection is **only an external inspection** and should be done without “disturbing” the filtration components.

On a daily basis, visually inspect the external condition of the complete air cleaner system. The following items should be inspected:

1. Check the Donaldson Radialseal™ air cleaner canister for damage. Make sure the cover is in place and the cover latches are secure—do not run the engine without the air cleaner cover in place and secure.
2. Inspect both air intake hoses for cracks, nicks, cuts, etc., and check the hose clamps for tightness.
3. Check to make sure the air filter restriction gauge is in place and hose connections are secure.

Battery

NOTE: For initial battery service during setup, refer to **Battery Service** in **Assembly Instructions**.

IMPORTANT: Make sure battery is securely mounted in the frame. A loose battery may cause damage to the case resulting in acid leakage and severe damage to the machine. A hazard may be created by damage to critical working parts and safety systems.

CAUTION

Important Battery Service, Installation, and Charging Tips for Electronic Fuel Injection Engines:

- Do not allow the battery cables to touch opposing terminals. When connecting battery cables attach the positive (+) cable to positive (+) battery terminal first, followed by negative (-) cable to negative (-) battery terminal.
- Never start the engine when the cables are loose or poorly connected to the battery terminals.
- Never disconnect battery while engine is running.
- Never use a quick battery charger to start the engine.
- Never “jump start” the engine using another source. Electricity fluctuations can damage the ECU (Electronic Control Unit).
- Always disconnect negative (-) battery cable lead before charging battery, and also unplug harness from ECU before performing any welding on equipment.

Electrolyte Level

The battery electrolyte level should be checked **after every 25 hours** of operation. To check electrolyte level:

1. Remove battery cell filler caps.
2. Check the electrolyte level. If the level is below the bottom of the vent well, fill with distilled water to the bottom of the vent wells [1/4 to 1/2 in. (6 to 13 mm) above the plates].
3. Replace filler caps.

IMPORTANT: DO NOT overfill the battery. Electrolyte will overflow through the vented caps onto parts of the machine and **WILL** result in severe corrosion.

Cleaning the Terminals

If battery terminals are corroded, **remove battery** from the mower. Using a wire brush, remove corrosion with a solution of **one part baking soda and four parts water**. Rinse with clean water. Coat the terminals with petroleum jelly or terminal protector spray to retard further corrosion.

Charging the Battery



BATTERIES PRODUCE EXPLOSIVE GASES

- **Charge the battery in a well-ventilated area, so that gases produced while charging can dissipate.**
- **Keep sparks, flames, and smoking materials away from the battery at all times.**
- **Make sure the battery cap vents are open (check manifold vent on each cap).**
- **Make sure the battery charger is unplugged before connecting or disconnecting cables to the battery.**

Check the battery charge by measuring the specific gravity of electrolyte; if specific gravity is less than 1.225, the battery will need to be charged as follows:

IMPORTANT: Always disconnect the negative (-) battery terminal before charging. Failure to do so can result in damage to the ECU.

1. Charge the battery at 15 amps for 10 minutes. **DO NOT** exceed 20 amps maximum recommended charging rate. Charge until specific gravity is at least 1.250. Total charging time should not exceed one (1) hour.
2. After charging the battery, use distilled water to adjust the electrolyte level to the bottom of the vent wells [1/4 to 1/2 in. (6 to 13 mm) above the plates].

Tire Pressure

Inflate tires to pressures shown below:

Deck Caster Wheel* = 20 PSI (137 kPa)
 Drive = 15 PSI (103 kPa)
 Tailwheel = 20 PSI (137 kPa)

* If equipped with optional pneumatic tires

Wheel Bolt Torque

Check the eight (8) lug bolts that mount the drive tires. **Every 100 hours** they should be torqued to 75 to 85 lb·ft (102 to 115 N·m).

Sharpen Mower Blades

Check mower blade(s) for **straightness, sharpness, condition of the cutting edge, and balance every 10 hours** of operation (or more often when mowing abrasive type grass or operating on sandy soils). **Replace blades if worn, bent, cracked, or otherwise damaged** (refer to **REPLACING/REPAIRING the Mower Blades** in this section). Use the following procedure to check and sharpen blades:

NOTE: Keep blades sharp—cutting with dull blades not only yields a poor mowing job but slows the cutting speed of the mower and causes extra wear on the engine and blade drive by pulling hard.

1. Stop the engine, remove ignition key, and disconnect the spark plug wires **before** raising the mower deck to service blades.
2. Raise the deck and **secure** it in the **TILT-UP** position. Refer to **CLEANING the Grass Build-up in Mower Deck Housing** in this section for deck raising instructions.



NEVER operate cutter blades with the deck in the raised position.

NOTE: PTO shaft must be **disconnected** before checking blades for straightness.

3. Check the blades for **straightness** by marking the blade tip position inside the deck housing, and then rotating the opposite end of the blade to the same position and comparing. If the difference in blade tip track is **more than 1/8 in. (3 mm)**, the blade is bent and **should be replaced**.

(continued on next page)

! WARNING

DO NOT try to straighten a blade that is bent. NEVER weld a broken or cracked blade. ALWAYS replace with a new blade to assure safety.

- If the blade cutting edge is **dull or nicked**, it should be sharpened. Remove blades for sharpening by grasping the end of the blade using a rag or a thick, padded glove, while loosening and removing the nut, lock washer, and flat washer that mounts the blade.
- Grind cutting edge at the same bevel as the original. Sharpen only the top of the cutting edge to maintain sharpness.

NOTE: Blades can be sharpened with an electric blade sharpener, conventional electric grinder, or a hand file.

! CAUTION

ALWAYS wear eye protection and gloves when sharpening a blade.

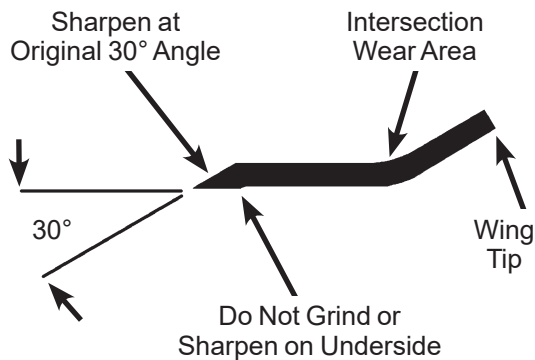

Mower Blade Profile for Sharpening

- Check blade balance by positioning the blade **horizontally** on a blade balancer or use a nail or shaft through the center hole. If either end of the blade rotates downward, grind (remove) metal on that end until the blade will balance. The blade is properly balanced when neither end drops. Balance of a blade is generally maintained by removing an equal amount of material from each end of the blade when sharpening.

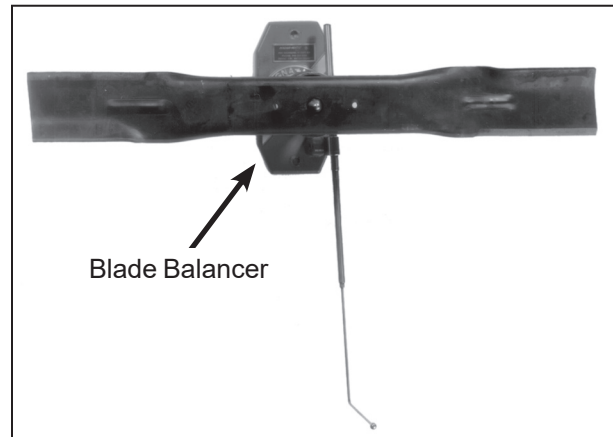

Blade Balanced on Magnetic Wall-Mounted Balancer

- Mount the blade with wing tips pointing up into the housing. For **gear driven decks** reinstall the blade, washer, lock washer, and nut. **Tighten the nut to 60 lb-ft (81 N·m).** For **belt driven decks** reinstall the spacer (if applicable), blade, washer, and bolt. **Tighten the bolt to 70 lb-ft (95 N·m).**

NOTE: When reinstalling blades on **GHS** models, remember, the blades counter-rotate and the LH and RH blades must not be switched. Check for proper blade rotation before installing blades on the deck. Refer to **Blade Rotation** illustrations shown in **Clogging Checklist** in **Operating Instructions** for correct blade rotation.

Drive Belts

Raise the body and inspect the condition of the four (4) belts (3 belts on SD models) **every 25 hours** of operation—engine PTO drive, jackshaft drive, hydrostatic ground drive, and GHS blower drive. If the belts show **signs of cracking or deteriorating**, the belts should be **replaced**. Refer to **REPLACING/REPAIRING the Drive Belts** in this section.

Mower Deck Gearbox Oil Seals

The mower deck gearbox seals should be inspected **every 25 hours** for evidence of oil leaking; **particularly the lower oil seal on the blade drive gearbox**. This seal is protected by the trash guard on the blade hub and seal protector plate on the housing, but is still vulnerable to seal damage due to operating in an adverse environment. The mower blade must be removed for inspection of the seal, so it is recommended to **inspect the gearbox seals when blades are removed for sharpening**. If an oil leak is noted, the seal should be replaced and the gearbox assembly relubricated. Refer to **LUBRICATION for Mower Deck Gearbox Lubrication** in this section.

Spark Plugs

Every 200 hours of operation, remove the spark plugs, inspect, clean, and reset the gap (or replace with **new plugs**). Before removing the spark plugs, clean the area around the base of the plugs to keep dirt and debris out of the engine. Clean spark plugs with a wire brush. **DO NOT** use an abrasive grit type cleaner. If the electrodes are burned short or pitted, replace plugs with Champion® type RC12YC (or equivalent). Check spark plug gap with a wire-type feeler gauge and set the gap at 0.030 in. (0.76 mm). Reinstall and tighten to between 18 and 22 lb·ft (24 to 30 N·m).

Ignition Wires

Good preventive maintenance calls for complete **replacement** of spark plug wires **every two (2) years**.

Fuel Lines and Clamps

NOTE: The engine fuel injection system is pressurized and should be serviced by a Walker dealer or authorized Kohler engine service outlet.

Every year, inspect the fuel supply line from the tank to engine for deterioration or damage. Also, inspect the fuel line **clamps for tightness**. Good preventive maintenance calls for complete **replacement** of fuel lines and clamps **every two (2) years**.

Engine Starter

Yearly or every 500 hours disassemble and clean the solenoid shift starter. Refer to the Kohler Service Manual for this procedure or contact an authorized Kohler engine dealer to perform this service.

Transmission Control Setting

On a **yearly** interval or when an out-of-adjustment condition is observed, check the transmission control for proper function as follows:

Neutral-Park

With the mower parked on level ground, start and run the engine, first at idle and then normal operating speeds. With the FSC in the **NEUTRAL-PARK** position, there should be no movement of either drive tire. If the tire(s) are “creeping” forward or reverse, refer to **ADJUSTMENTS for the Neutral Function Adjustment - Step 4** in this section.

Straight Ground Tracking

Check for straight ground track by driving on a smooth, level surface with hands off the steering levers. Set the FSC at different speeds and observe if the mower moves in a straight line (use a cement joint or other line on the ground for reference). If the machine is drifting to the right or left, refer to **ADJUSTMENTS for Straight Ground Travel Adjustment - Step 5** in this section.

Blade Brake Action



It is important to check and maintain blade brake action for safe operation of the machine.

Check the function of the cutter blade brake (and blower brake on GHS models) by engaging the blade clutch (PTO), operating the engine at full throttle, then disengaging the clutch and measuring how quickly the blades stop. Watch the rotation of the blade drive shaft and blower pulley as a visual indication that movement has stopped. If the brake is **working properly, all rotation will stop five (5) seconds after disengagement** of the clutch. If the brake system malfunctions - blades do not stop in five (5) seconds - adjust or repair the brake before operating the mower. Contact your Walker dealer for this service or refer to **ADJUSTMENTS for Clutch Disengagement/Brake Action, Step 3 - Blade Brake Band Adjustment** on page 86.

PTO U-Joints

The PTO U-joints should be inspected **yearly** for looseness and wear. If either is noticed, the respective shaft or tube should be replaced. A worn U-joint can cause vibration and extensive damage to the PTO and the whole machine.

Safety Switch System



It is important to check and maintain the safety switch system for safe operation of the machine.

There are four (4) safety interlock switches on the tractor: Seat Switch, FSC Neutral-Park Switch, PTO Switch, and Parking Brake Switch.

NOTE: There is a 1/2 second time delay function on the seat switch to avoid engine power interruption when driving over bumps.

If any of the following conditions occur during starting or operating, a safety interlock switch may be malfunctioning. Contact your Walker dealer for troubleshooting and/or replacement.

- With or without an operator in the seat, the **engine starts** with the Forward Speed Control (FSC) and/or the PTO engaged, or the parking brake disengaged.
- With an operator in the seat and the parking brake engaged, **the engine starts but dies** soon after the parking brake is disengaged and the Forward Speed Control (FSC) or PTO is engaged.
- **Without** an operator in the seat, the engine starts and **continues to run** with the Forward Speed Control (FSC) and/or PTO engaged, or the parking brake disengaged.
- With an operator in the seat, the Forward Speed Control (FSC) and PTO disengaged, the parking brake engaged, and Oil Pressure Warning Horn sounding, but the **starter will not engage**.

Forward Speed Control Friction Lock

The FSC friction lock is designed to **hold the selected forward travel speed** when the steering levers are moved and yet the friction is not too heavy to make **moving the FSC control** difficult (too much friction). The procedure for checking the FSC friction lock is as follows:

1. With the engine off, place the FSC in the full **FORWARD** position and pull both steering levers back; the FSC lever should not move. If the FSC lever moves back when the steering levers are pulled back, the **friction needs to be increased**.
2. With the steering levers held back, move the FSC lever back from the **FORWARD** position. With a proper amount of friction adjusted, the FSC lever should move back with a slight amount of resistance (friction). If the FSC lever movement is "stiff", **the friction needs to be decreased**.

If the FSC friction lock needs to be adjusted, refer to **ADJUSTMENTS for Forward Speed Control Friction Lock** in this section.

REPLACING/REPAIRING

DANGER

To prevent accidental starting of the engine when replacing parts or repairing the machine, remove the key from the ignition switch and disconnect the spark plug wires.

IMPORTANT: ALWAYS use genuine factory replacement parts. Substitute parts **CAN** result in product malfunction and possible injury to the operator and/or others.

Drive Belts

There are **four (4) individual belts** on GHS models or **three (3)** belts on SD models:

- Jackshaft Drive Belt
- Engine PTO Drive Belt (3 Groove Power Band)
- GHS Blower Drive Belt (GHS Model Only)
- Hydrostatic Ground Drive Belt

The belts may be removed and replaced using the **procedures described on the following pages.**

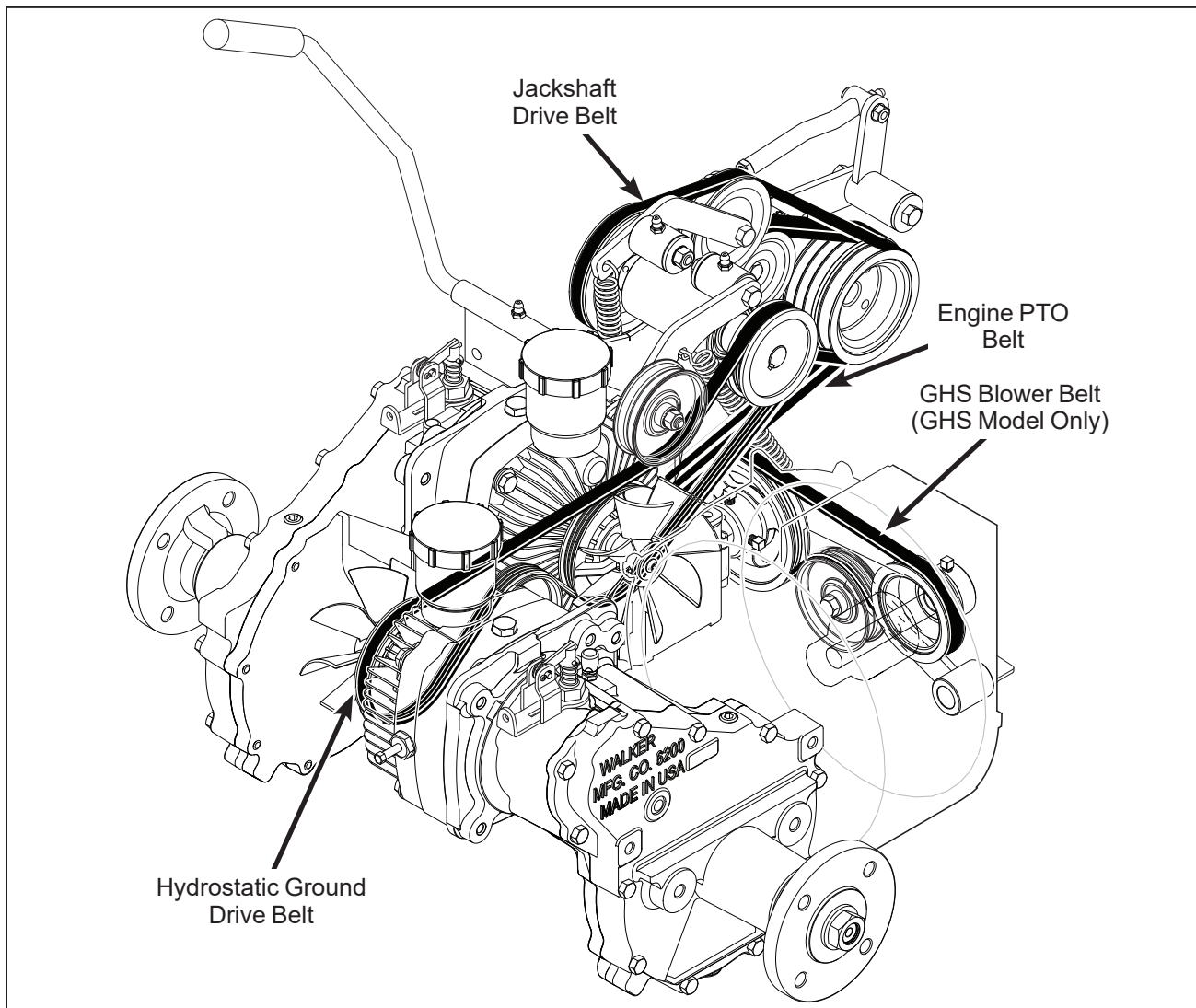

Belt Locations

Engine PTO Drive Belt (3 Groove Power Band)

1. To remove the engine PTO drive belt:
 - a. Remove the jackshaft drive belt from its idler pulley (by pushing down on idler pulley) and let the belt drop down out of the way.
- NOTE:** Step (a) is not essential to removing the PTO belt, but it makes more room to work with the PTO belt.
- b. Push the clutch idler pulley down (until the PTO belt tightener stop block contacts the frame) and then shift the belt off the idler pulley (to the inside).

- c. Raise the clutch lever (engage position) to lift the clutch idler away from the belt.
 - d. Next remove the belt from the engine pulley and then the PTO drive pulley.
2. Install the PTO drive belt by reversing the removal procedure.

IMPORTANT: Make sure the belt is installed **inside** the four (4) belt guide pins.
 3. Refer to **ADJUSTMENTS** of **Blade Clutch (PTO)** in this section to check and make the following adjustments:
 - a. Clutch engagement for proper belt tension.
 - b. Clutch disengagement and brake action.

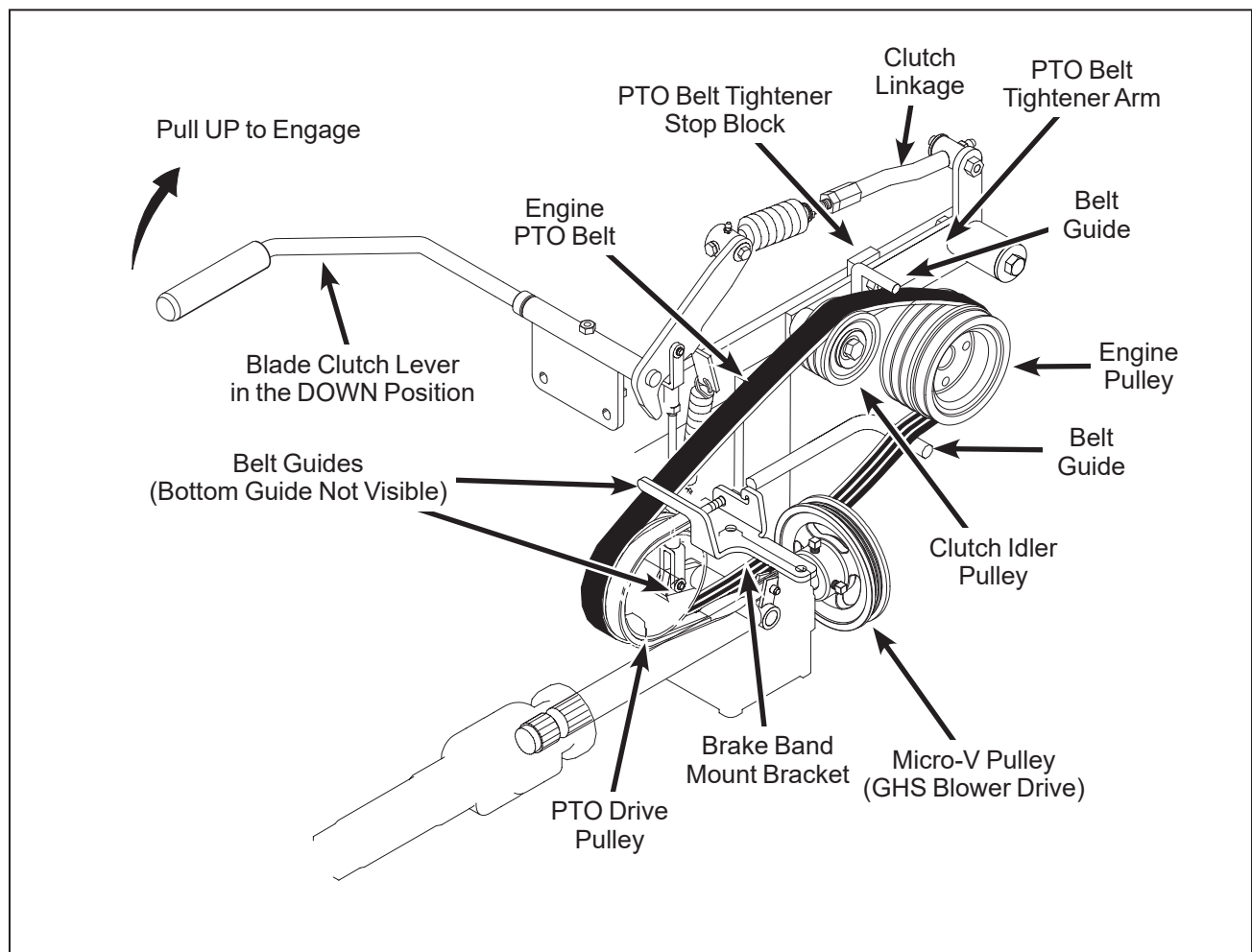

Engine PTO Drive Belt Removal

Jackshaft Drive Belt

1. To remove the jackshaft drive belt:

a. Remove the engine PTO drive belt, as described in previous section.

b. Relax the belt by depressing the spring-loaded idler arm.

c. Roll the belt off the jackshaft pulley and remove.

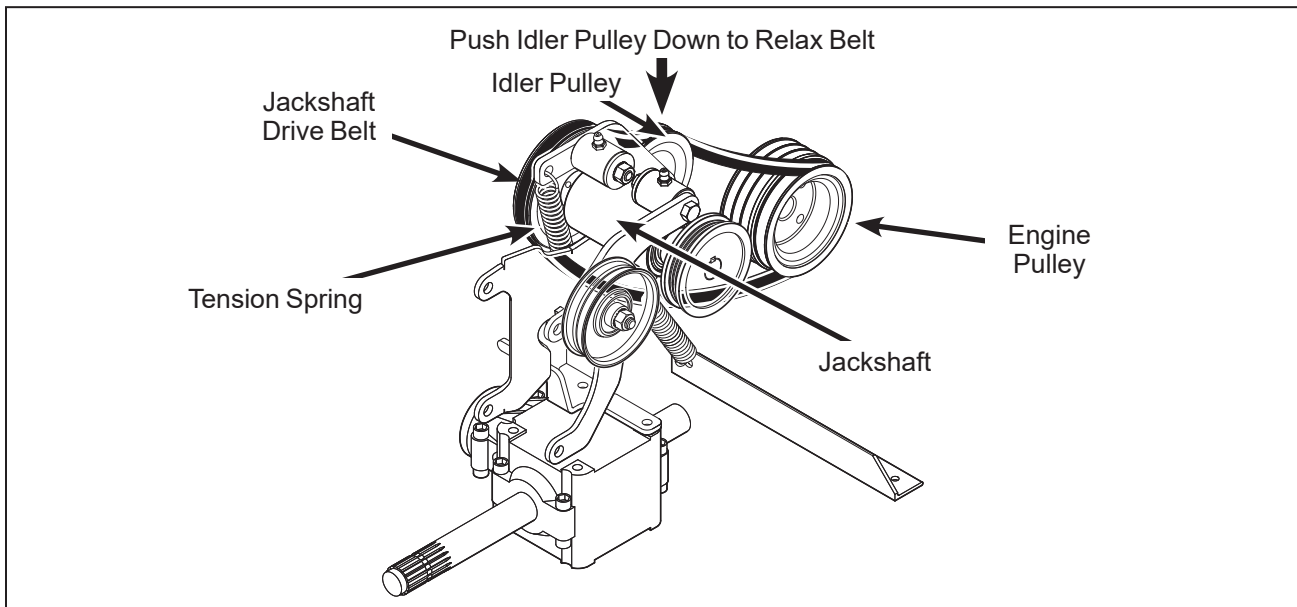

Jackshaft Drive Belt (Disengaged)

2. Reverse the removal procedure to replace the jackshaft drive belt.

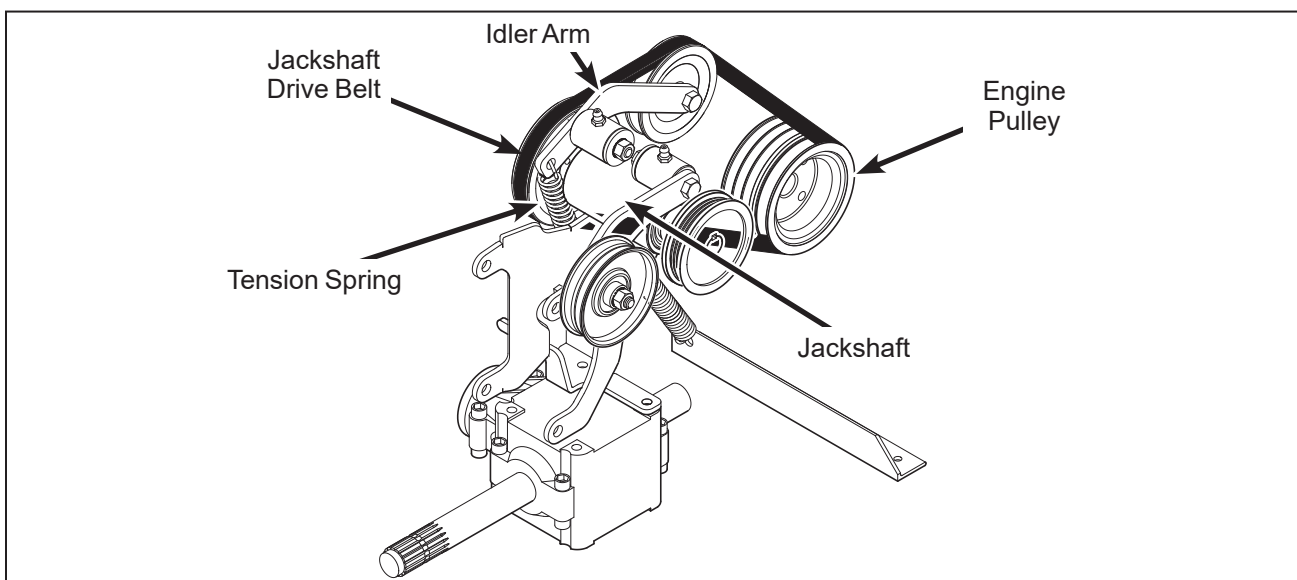

Jackshaft Drive Belt (Engaged)

GHS Blower Drive Belt

1. Remove the GHS blower drive belt tension by depressing the idler pulley on the tightener arm. Roll the belt off the blower pulley.

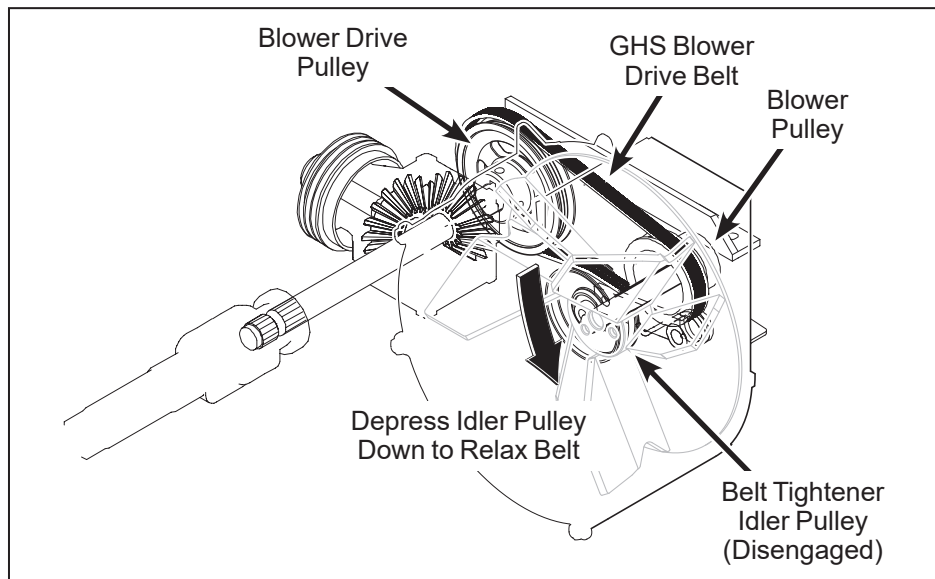

GHS Blower Drive Belt Assembly (Disengaged)

2. Reverse the procedure to install the GHS blower drive belt.

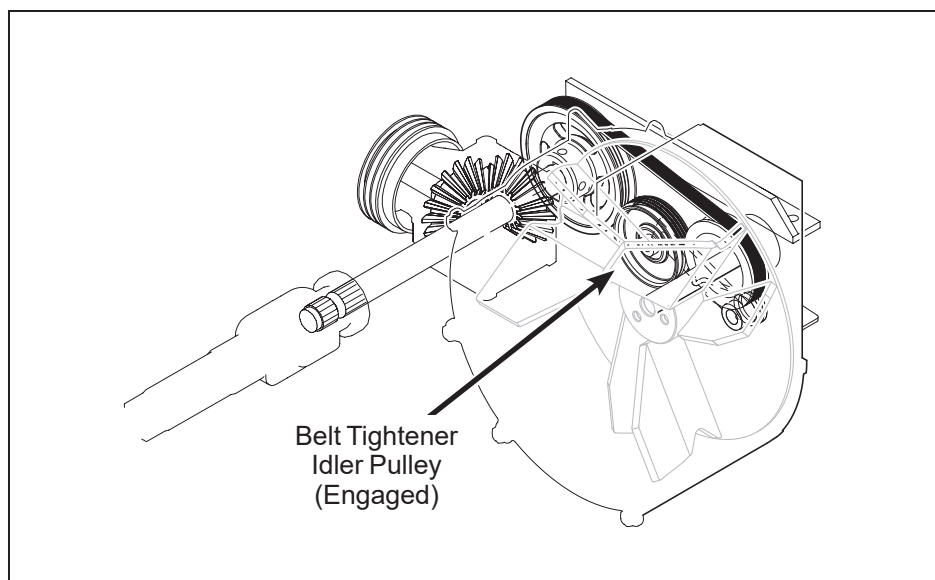

GHS Blower Drive Belt Assembly (Engaged)

Hydrostatic Ground Drive Belt

1. To remove the hydrostatic ground drive belt:
 - a. Raise the spring-loaded belt tightener arm and idler pulley to relax belt.
 - b. Slide belt off pulleys, then release the idler.

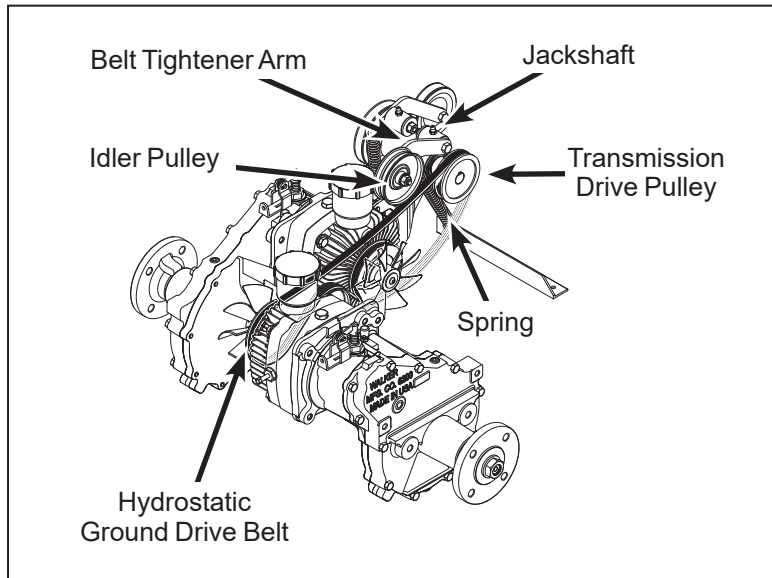

Hydrostatic Ground Drive Belt Assembly (Disengaged)

2. Reverse the procedure to install the hydrostatic ground drive belt.

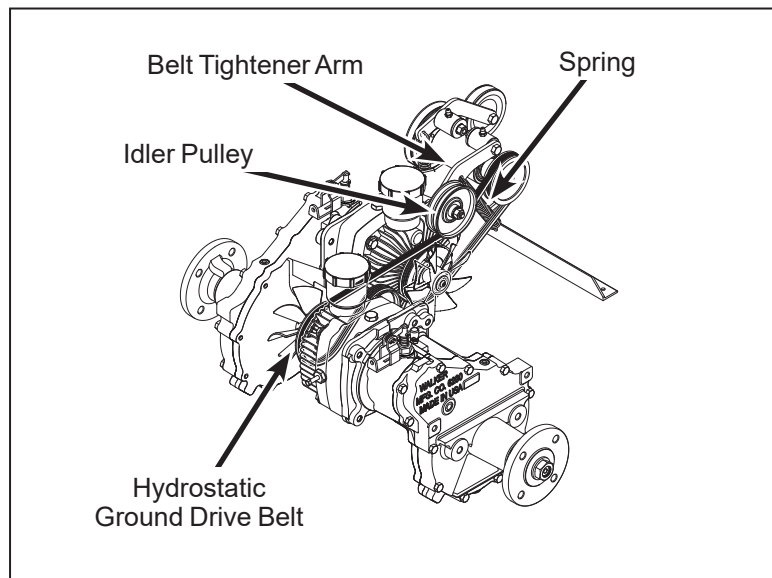

Hydrostatic Ground Drive Belt Assembly (Engaged)

Fuel Filter



Gasoline is extremely flammable and can be highly explosive. To minimize danger:

- Before servicing the fuel system:
 - 1) Disconnect the spark plug leads.
 - 2) Disconnect the negative (-) battery cable from battery.
- Use only an approved fuel container for gasoline.
- DO NOT allow open flames or sparks near the machine while performing maintenance or refueling; DO NOT smoke while working with fuel.
- Wipe up spilled gasoline immediately and completely.

Model T27i is equipped with an in-line fuel filter between the fuel tank and the fuel pump (low pressure fuel pump). Visually inspect the filter periodically, and replace the filter **yearly**. Use Walker P/N 5020-3 or Kohler P/N 24-050-13, 9-12 microns for replacement filter.

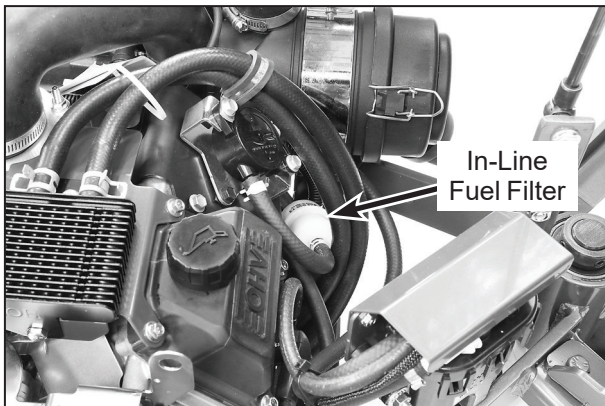

Fuel Filter Location

IMPORTANT: Replace the fuel filters only in a clean area where the fuel line and connections will not be contaminated by dust and dirt.

1. Expand and slide clamps on either side of the filter away from filter and pull fuel lines off filter.

2. Replace filter, making sure that the arrow on the filter is aligned with the fuel flow through the filter.
3. Verify that the fuel lines and clamps are securely attached, and that no fuel leaks are present.

Blade Overload Shear Bolts

NOTE: Blade shear bolts are not used on belt driven decks.

On gear driven decks, each cutting blade is keyed to the blade hub by **two (2) shear bolts** (10-24 x 5/8 in. stainless steel machine screws). These bolts are designed to shear and protect the blade drive gearbox from damage if the blade encounters a shock load.

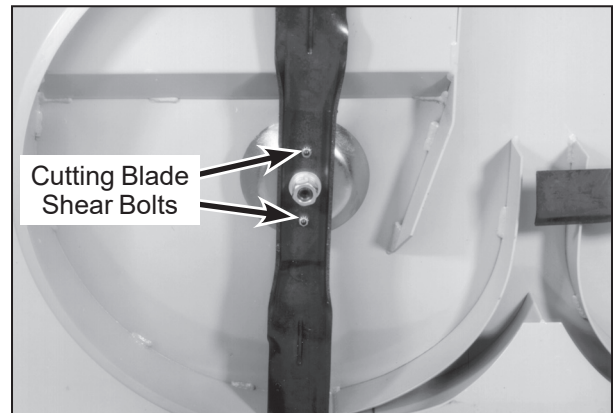

Cutting Blade Shear Bolts

NOTE: Tightening the **5/8-18 blade mounting nut to 60 lb-ft (81 N·m)** is also important for proper shock load protection. It is important to **not over-tighten** the mounting nut since this defeats (overrides) the function of the shear bolts.

If these bolts shear, remove the blade and install new bolts. Refer to **CHECKING/SERVICING** in this section for **Sharpen Mower Blades** which describes the blade removal and installation procedure.

After reinstalling the blade, check blade timing (on gear driven decks) by moving blades through **one (1) complete revolution**. Make sure blade tips pass clear of each other. If timing is incorrect, contact your Walker dealer.

Mower Blades

Mower blades are removed and remounted as described in **Sharpen Mower Blades** instructions (refer to **CHECKING/SERVICING** in this section). During the course of sharpening and inspecting mower blades, if there are **any of the following conditions of wear or damage, blades should be replaced** for reasons of safety and performance of the machine:

- An excessive amount of the **flat section** of the blade has been **ground away** (removed) when the blade is sharpened. Replace the blade **when less than a 3/4 in. (19 mm) flat section remains** at the blade tip.
- Examine ends of the blade carefully, especially the intersection where the flat section of the blade turns up to form the “wing tip” (refer to **CHECKING/SERVICING** for **Mower Blade Profile for Sharpening** illustration in **Sharpen Mower Blades** instructions). Since sand and abrasive material can wear metal away in this area, the blade should be **replaced when metal thickness has worn to 1/16 in. (1.6 mm) or less**.

DANGER

When blades are operated over sandy soil, and if blades are allowed to wear, a “slot” may be worn into the wing tip of blade. Eventually a piece of the blade may break off creating a serious potential for injury or damage.

- Check the blades for **straightness** by marking blade tip position inside the deck housing and then rotating the opposite end of the blade to the same position and comparing. If the difference in blade tip track is **more than 1/8 in. (3 mm)**, the blade is bent and **should be replaced**.
- Inspect the blade surface, especially in formed areas, for **cracks**. Replace the blade if any cracks are found.

WARNING

DO NOT try to straighten a blade that is bent. NEVER weld a broken or cracked blade. ALWAYS replace with a new blade to assure safety.

Reinstall the blades following procedure from **Sharpen Mower Blades** instructions in **CHECKING/SERVICING** in this section. If blades are replaced, always use **Walker original equipment blades** to ensure safety and optimum performance. The quality and performance of **replacement blades offered by other manufacturers** cannot be guaranteed, they **could be dangerous**.

CAUTION

ALWAYS use genuine factory replacement parts. Substitute parts CAN result in product malfunction and possible injury to the operator.

ADJUSTMENTS

Transmission Control

The following instructions reflect the most current transmission linkage configuration with a spring/dampener connected to the steering lever (starting S/N 11-109716) and the FSC using direct linkage instead of a sliding fork disconnect (starting S/N 15-134121). Earlier units will need to use the transmission control adjustment instructions from the P/N 9000-30 Service Manual.

IMPORTANT: The proper adjustment of the transmission control stops is **essential** for efficient operation and life of the transmission. These stops are properly adjusted at the factory and should only require readjustment if the transmission or related control linkage is removed or changed.

NOTE: It would not be unusual for a new machine, after initial 5 or 10 hours of operation, to begin to not travel straight (this is due to the break-in of the transmissions). In this case, proceed to *Straight Ground Travel Adjustment - Step 5*.

IMPORTANT: The following adjustment procedures are sequential. Check and adjust each function in the order given.

Steering Lever Position Adjustment - Step 1

NOTE: For proper operation, the steering levers should be adjusted to sit evenly using the following procedure.

1. Examine the steering levers to make sure they are **parallel front to back** in relation to one another. If they are not equal, adjust accordingly. (The handles may or may not be even at this point, see **Steering Handles** adjustment this section.)

NOTE: The LH steering lever is non-adjustable. This procedure will require adjustment of the RH lever to make it even with the LH lever.



Lever Alignment

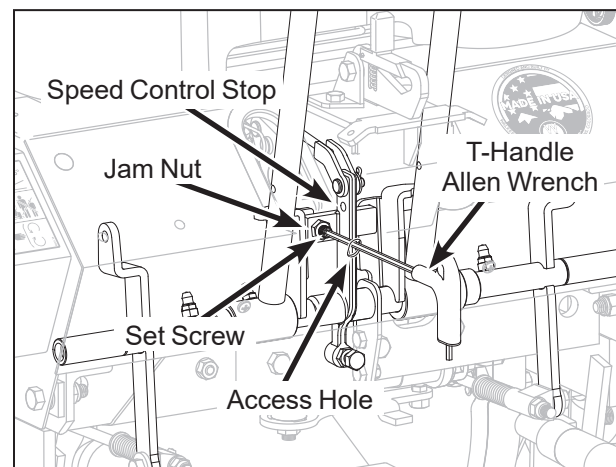

Lever Position Adjustment

2. Adjust the position of the RH Steering lever using the adjustment screw on the Speed Control Stop as shown in the **Lever Position Adjustment** illustration. The screw is adjusted with the tractor body in the normal operating position (not raised) using an access hole in the front panel. Loosen the jam nut and adjust the lever position to match the LH lever position. Tighten jam nut after the adjustment.

Set FSC Travel Limits (Stop) - Step 2

1. Move the Forward Speed Control (FSC) lever to the most **FORWARD** position.
2. Check clearance of the RH and LH steering lever actuator arms with the frame and **adjust forward stop bolt** so each lever clears the frame by at least 1/16 in. (1.6 mm). Clearance of the arm to the frame should be checked while **applying pressure back** on the arm to remove any slack in the linkage.

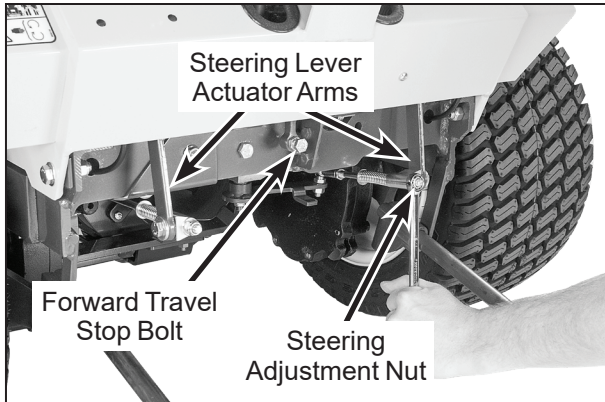

Forward Speed Control Stop and Steering Lever Adjustment

3. Tighten the jam nut on the forward travel stop adjusting bolt.

Set Maximum Forward Travel Speed (Stop) - Step 3

1. Position the FSC lever to the most **FORWARD** position.
2. Turn the steering lever adjustment nut(s) until 2 or 3 threads are showing past the end of the nut.
3. Loosen the jam nut at the other end of the control rod (where it connects to the transmission control arm).
4. For each steering lever, use a wrench on the adjustment nut, turn the control rod counter-clockwise (CCW) until the steering lever begins to move backward, then make two additional turns. Next, reverse and turn the control rod clockwise (CW) until the **steering lever stops moving forward** and then **make one additional turn**. Tighten the jam nut.

NOTE: Failure to make at **least one extra turn** on the control rod can place excessive loads on the transmission internal control stops and cause internal wear and damage to the transmission. Making additional turns beyond one turn reduces the maximum forward travel speed.

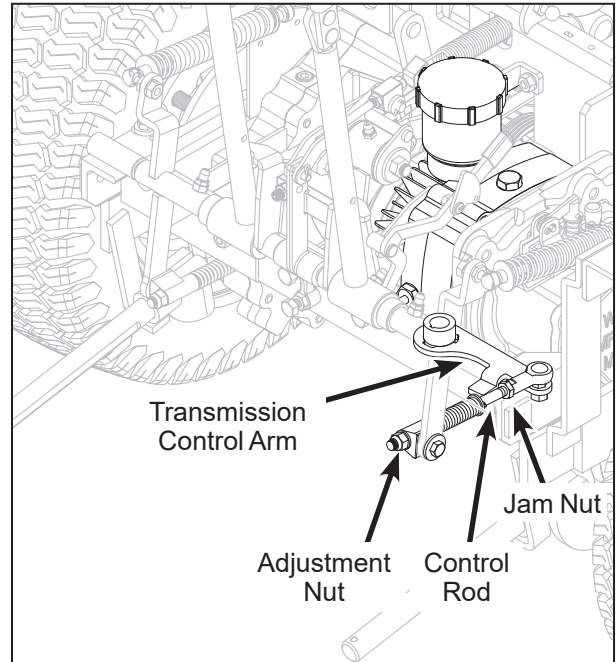

Transmission Control Rod and Arm Location (Front Body Hidden for Clarity)

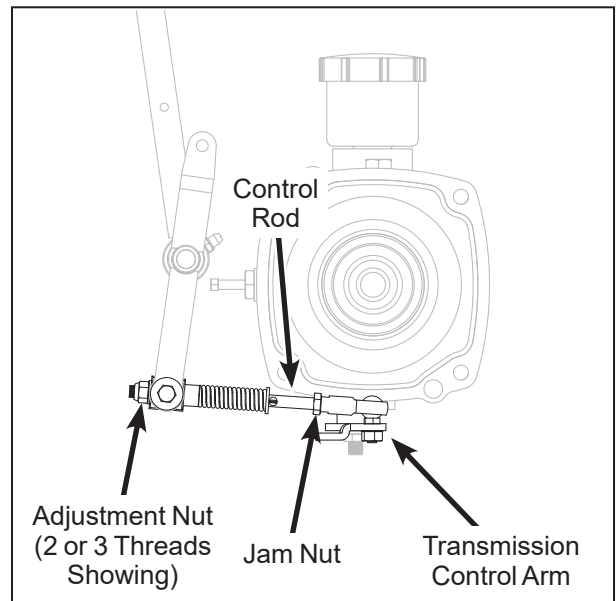

Adjustment Components

Neutral Function Adjustment - Step 4

1. Securely block the tractor up so the drive tires are off the ground.
2. Move the FSC lever to the **NEUTRAL-PARK** position (rear travel limit).

3. Start the engine (operate first at idle and then normal operating speeds) and **check for movement of the drive wheels**.

NOTE: If the engine will not start, check the operation of the neutral safety switch.

CAUTION

NEVER attempt to disconnect any safety devices or defeat the purpose of these safety devices.



Neutral Function Adjustment

4. If drive wheels are moving, **adjust the FSC neutral stop** by adjusting the FSC actuator rod (see **Neutral Function Adjustment** photo). If the drive wheels are moving backward, loosen the jam nut and lengthen the FSC actuator rod by turning the adjustment nut counterclockwise (CCW). If the drive wheels are moving forward, use the opposite clockwise (CW) adjustment.

5. At this point it may **not be possible** to adjust **both** wheels stationary since the differential adjust has not been made. (This is covered by the *Straight Ground Travel Adjustment - Step 5*.) In this case, the neutral adjustment should be made for one wheel stationary and the other moving **forward** slightly.
6. Check the **neutral safety switch** for closure and function with the FSC in neutral (the engine will not start when the switch is open).

Straight Ground Travel Adjustment - Step 5

1. Sit in the seat, start the engine (operate at normal speed), and with the FSC in the **NEUTRAL-PARK** position, check for **forward movement** of either drive wheel (if either wheel moves **backward**, refer back to *Neutral Function Adjustment - Step 4* and readjust). **Tighten the steering lever adjustment nut on the side of the mower with the wheel moving forward** until wheel movement stops.
2. Check for straight ground track on a **level surface** (with **hands off** the steering levers). Set the FSC at several different speeds and observe if the mower moves in a straight line (use cement joint or other line on the ground for reference).
3. If travel is not straight, **tighten the adjustment nut that is on the same side of the mower as the wheel that is moving too fast**, e.g., the mower tracks to the right, indicating the LH wheel is moving too fast, tighten the LH adjustment nut.



Straight Ground Travel Adjustment

Blade Clutch (PTO)

Clutch Engagement/Belt Tension

The clutch engagement and PTO belt tension are adjusted using the clutch actuator rod. Initially, after installing a new PTO belt, **after 10 hours and every 100 hours** thereafter, check and adjust for the two dimensions in the clutch actuator rod as shown in the **PTO Clutch Engaged** and **PTO Clutch Disengaged** illustrations.

Adjust the bolt head clearance [1/4 to 3/8 in. (6.35 to 9.53 mm)] first (clutch engaged), then adjust uncompressed spring length (clutch disengaged). The spring must be adjusted to an uncompressed overall length of 2-1/8 in. (54 mm). If adjustments are needed more frequently than every 100 hours to maintain the linkage dimensions, it may suggest problems with pulley wear or belt misalignment.

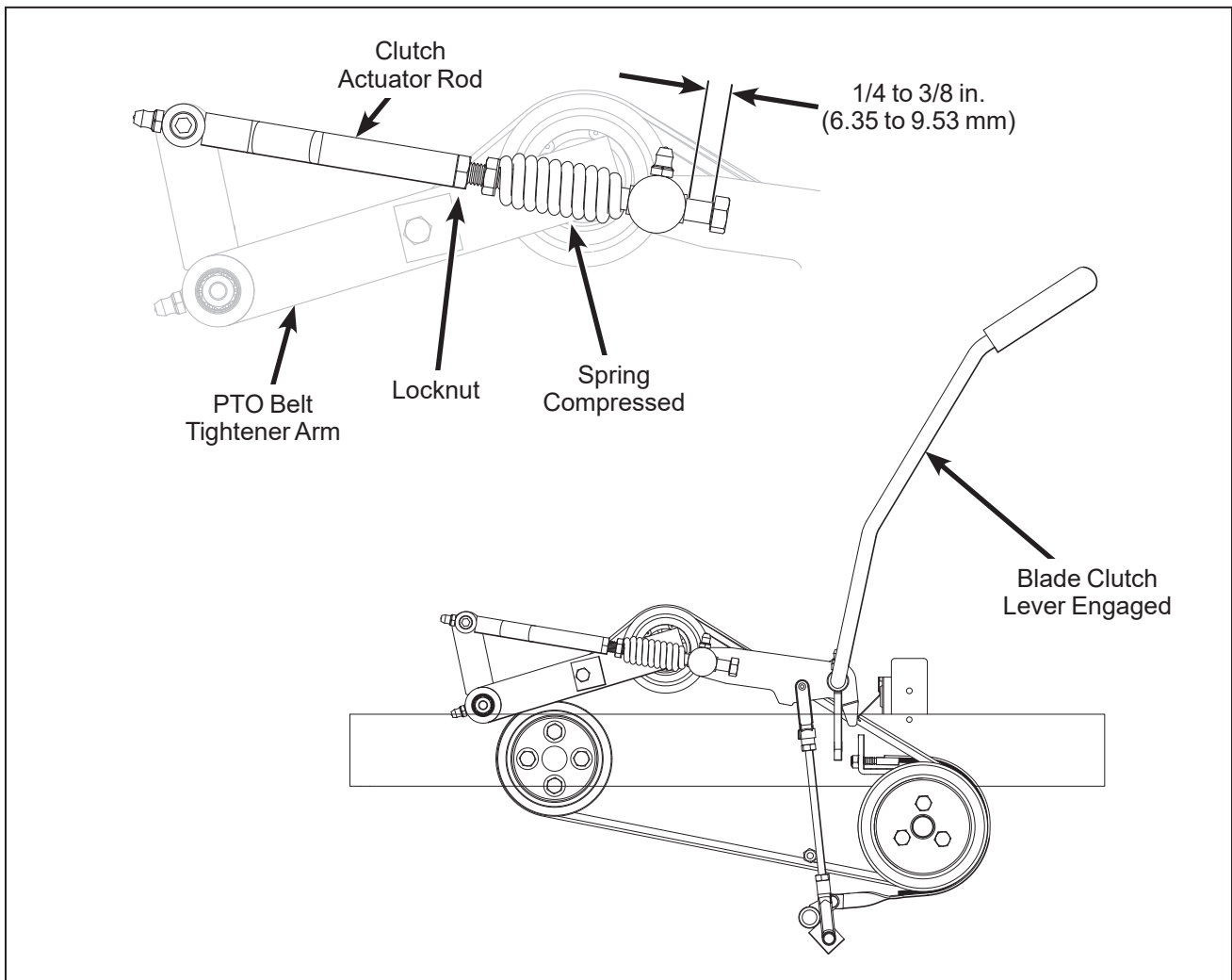

PTO Clutch Engaged

Clutch Disengagement/Brake Action

WARNING

It is important to check and maintain blade brake action for safe operation of the machine.

The **declutched or disengaged** position of the blade clutch idler pulley is adjustable and is set to give belt release **without excessive slack** and to apply the blade brake. The blade brake is activated by the brake actuator rod linkage to the clutch idler pulley mechanism. The brake is designed to stop the blades within five (5) seconds after disengaging the clutch.

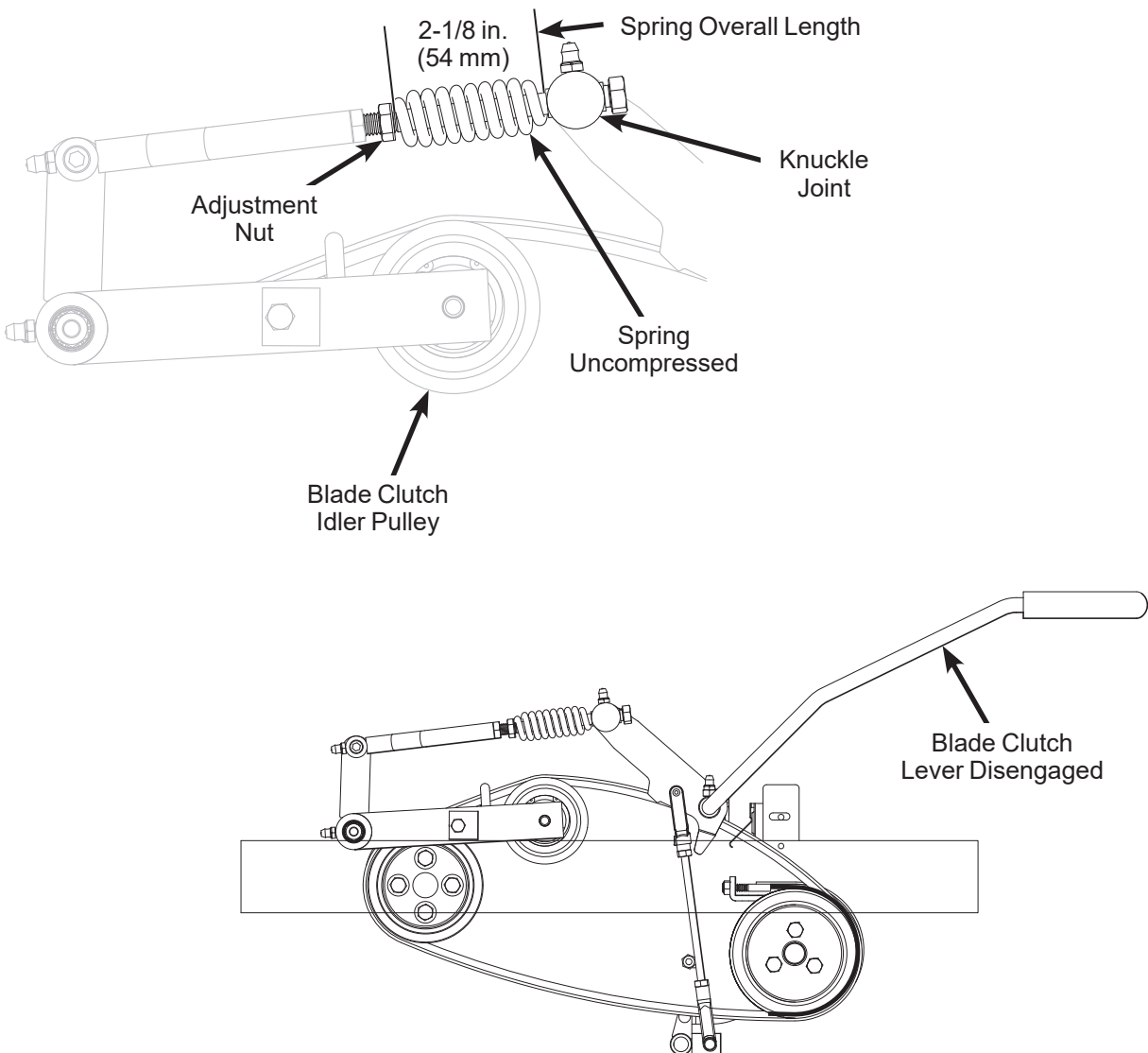

PTO Clutch Disengaged

Use the following procedure to check and adjust clutch disengagement and brake action:

Stop Block Eccentric Adjustment - Step 1

Use the stop block attached to PTO belt tightener arm to set the bottom position of the clutch idler pulley in the disengaged position. The stop block should contact the chassis to stop the clutch idler pulley from moving further down in the disengaged position. **If the stop block is not contacting the chassis** in the disengaged position, it will be necessary to **loosen the brake band adjustment nut**. The stop block is an "eccentric" block that will allow four adjustment positions from 5/16 to 11/16 in. (8 to 17 mm).

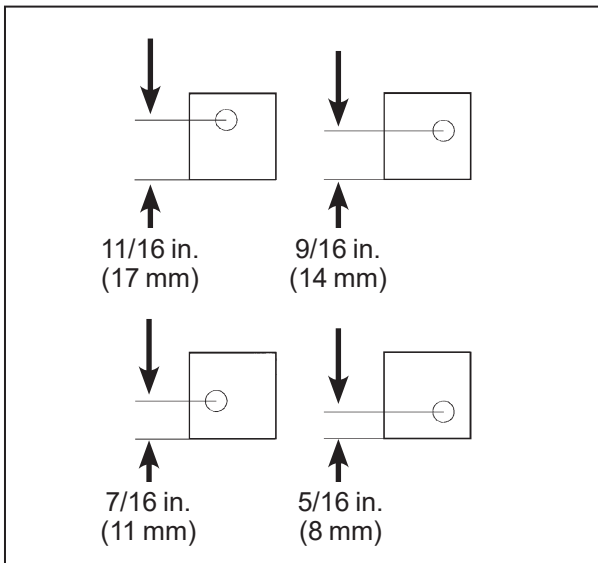

PTO Belt Tightener Stop Block Adjustments

Clutch Idler Pulley Travel Adjustment - Step 2

Adjust the stop block to give 1 to 1-1/2 in. (25 to 38 mm) pulley travel from "clutch engaged" to "clutch disengaged". To check and adjust the pulley travel, first engage the clutch, then measure the distance the pulley moves down as the clutch is disengaged and the stop block contacts the frame.

NOTE: The importance of this adjustment is if the pulley travel is excessive and the belt develops too much slack, the belt will derail when disengaged.

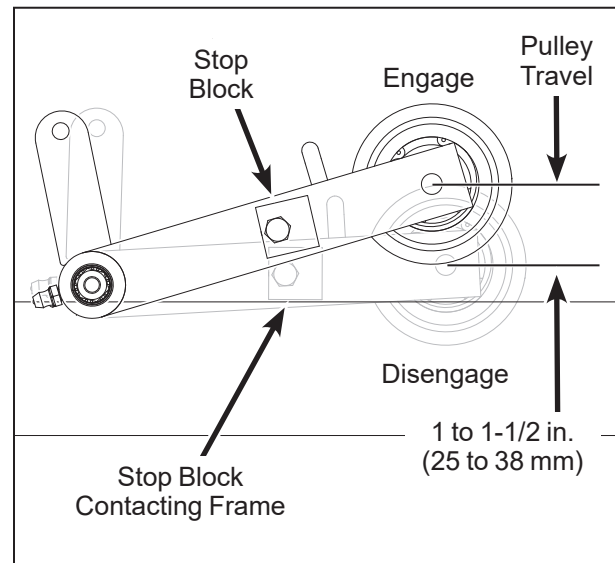

Clutch Idler Pulley Travel Adjustment

Blade Brake Band Adjustment - Step 3

After the pulley travel is set, make the following adjustment as needed:

1. Adjust the blade brake band, using the adjustment nut until there is a gap of approximately 1/8 in. (3 mm) between the PTO belt tightener stop block and chassis. If there are not enough threads on the brake band for adjustment, lengthen the brake actuator rod.

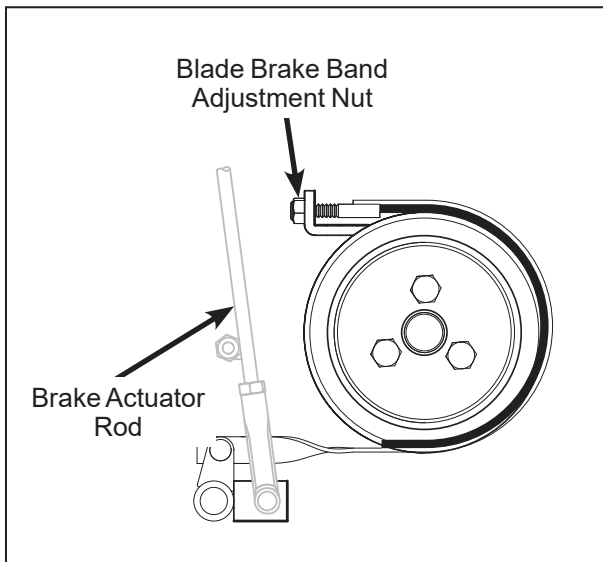

Blade Brake Band Adjustment

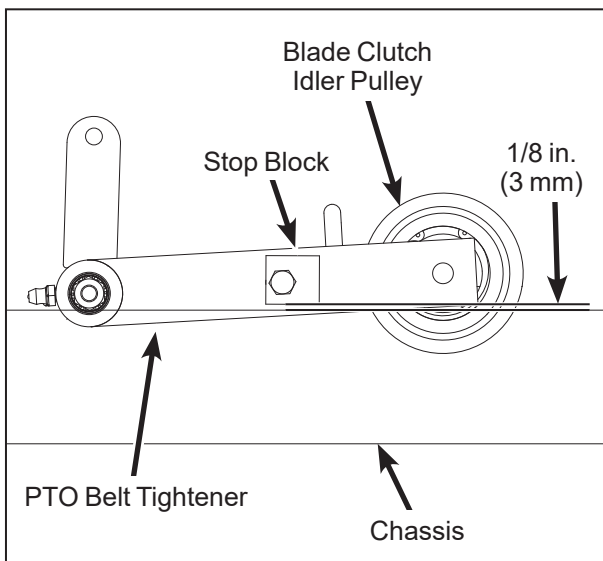

Blade Brake Band Adjustment

NOTE: The length of the actuator rod is adjusted by disconnecting the bottom clevis and shortening or lengthening accordingly. The standard pre-set length of the actuator rod is set at the factory at 8-1/4 in. (209 mm).

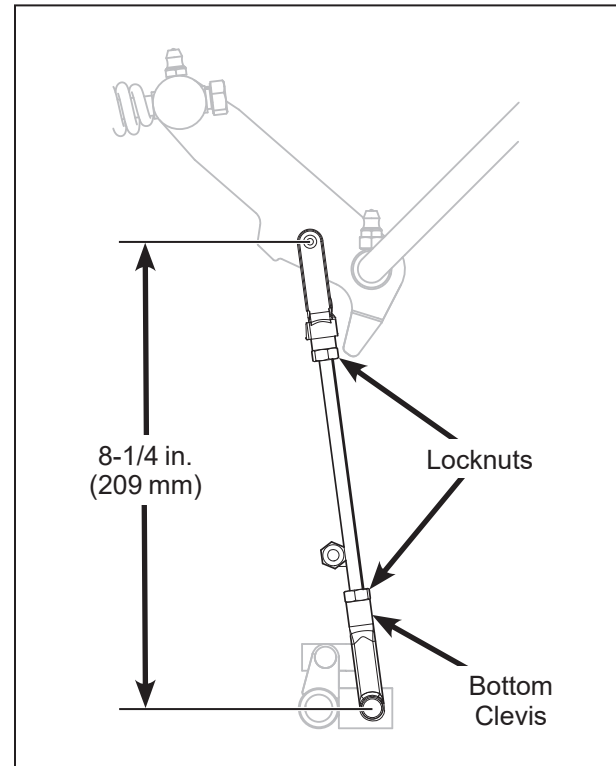

Brake Actuator Rod Adjustment

2. After adjustments are complete, check blade brake action as described in **CHECKING/SERVICING** the **Blade Brake Action** in this section. If blades do not stop within five (5) seconds, check the following:
 - a. Recheck 1/8 in. (3 mm) gap between stop block and chassis.
 - b. Make sure clutch and brake linkage are working freely (no binding).
 - c. Check the brake band lining.
 - d. Check the brake drum on the pulley. If excessive wear is present, it will be necessary to replace worn parts.

Forward Speed Control Friction Lock

The FSC friction lock is adjusted to **hold the selected forward speed** when the steering levers are moved. The friction should not be so heavy as to make **moving the FSC difficult** (too much friction). The procedure for checking and adjusting the FSC friction lock is as follows:

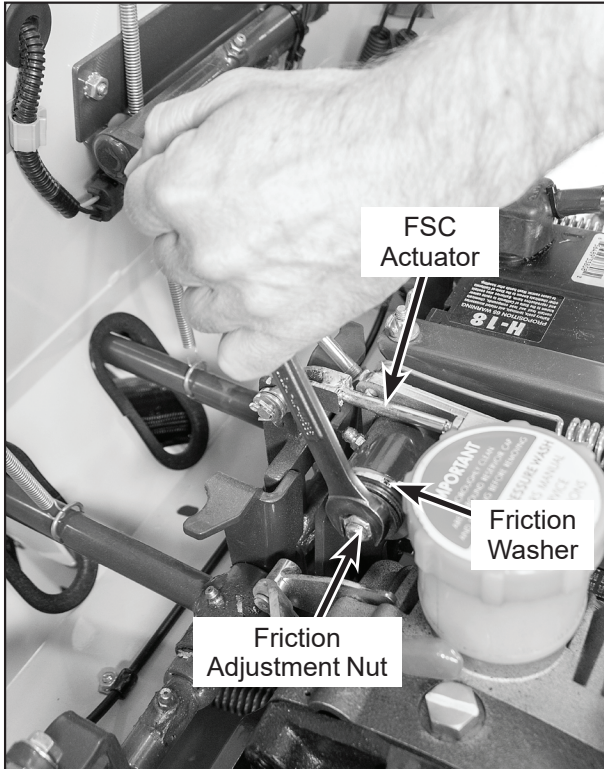

Forward Speed Control Friction Lock

1. Place the FSC in the full **FORWARD** position and pull both steering levers back; the FSC lever should not move. If the FSC lever moves back when the steering levers are pulled back, the **friction needs to be increased**.

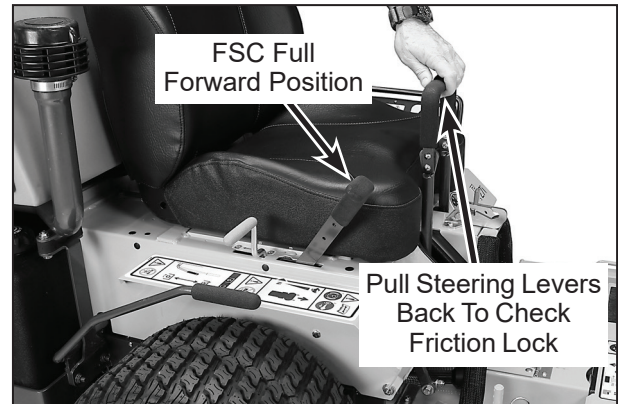

Forward Speed Control Position (Checking Friction Lock)

2. With the steering levers held back, move the FSC lever back from the **FORWARD** position. With a proper amount of friction adjusted, the FSC lever should move back with a slight amount of resistance (friction). If the FSC lever movement is "stiff", the **friction needs to be decreased**.
3. The FSC friction is **increased** or **decreased** by **tightening** or **loosening** the **friction adjustment nut**. Loosen or tighten the nut and check the control function until conditions of both steps 1 and 2 (above) are met.

Steering Handles

An adjustment range of approximately 3 in. (76 mm) is available on the steering handles - the handles can be adjusted forward or aft depending on the arm length of the operator. The handles can be adjusted by loosening the locknut at the pivot point and the locknut holding the handle in position in the adjustment slide. Adjust handles into most comfortable position and tighten both locknuts.

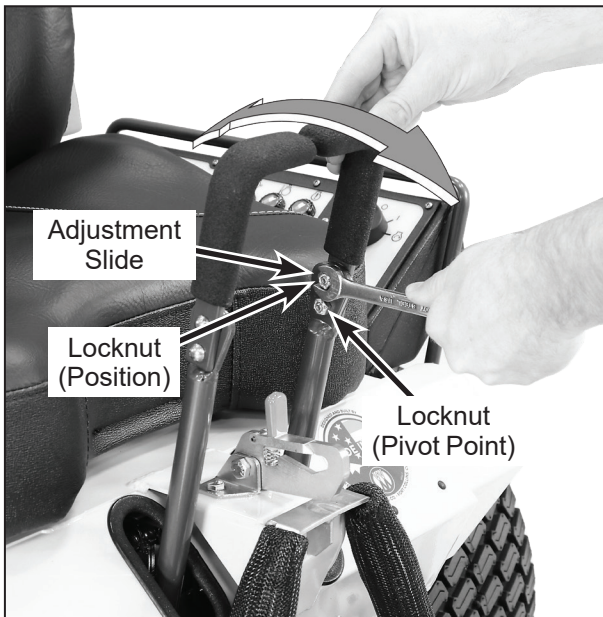

Steering Handle Adjustment

Tilt-Up Deck Adjustable Stop

When the carrier frame hinge joint is properly adjusted, the deck lock levers should move in and out of the engaged and disengaged positions freely. All four (4) hitch pins used for height adjustment should sit flush on the washers above the deck pin bushing. On a level surface, if any pin is sticking up (likely the front pins), tighten the opposite side or loosen the same side to lower the pin. Adjustments are made by loosening the jam nut and tightening or loosening the set screws on the Deck Mount Pivot Brackets. Retighten the jam nut when the adjustment is complete.

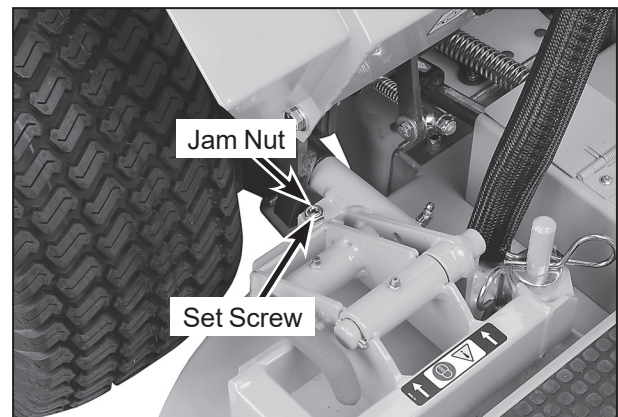

Tilt-Up Deck Adjustable Stop

GHS “Full” Signal Horn Adjustment

The vertical position of the Grass-Pak[®] switch is critical to make sure the catcher box does not over-fill causing the delivery chute to clog. The vertical position can be adjusted by moving the aluminum shaft and vane on the Grass-Pak[®] switch.

1. Position the discharge chute so that it is pointing straight back.
 - a. Turn the ignition switch to **ON (RUN)** and move the blade clutch to the **ENGAGED** position (engine not running).
 - b. Open the catcher back door and monitor the spout position (as it oscillates) and move the blade clutch to the **DISENGAGED** position and turn the ignition switch to the **OFF** position.

⚠ DANGER

PINCH POINT - SPRING LOADED DOOR

When lowering the door on the GHS catcher, **BE VERY CAREFUL** to keep hands, fingers, etc. out of the hinging mechanism and away from the door frame as the door closes. The springs that hold the door closed during operation are very powerful, and the door can slam shut with considerable force.

⚠ WARNING

DO NOT test the Grass-Pak[®] switch with the engine running. Projectiles **CAN** be thrown out of the grass delivery spout and **CAN** cause serious injury to bystanders or property damage.

2. Measure from the exhaust screen (top of catcher) to the top of the Grass-Pak[®] switch actuator vane, refer to **Adjusting the Grass-Pak[®] Switch** illustration. The proper measurement should be between 4 and 4-1/2 inches (10 and 11.5 cm).

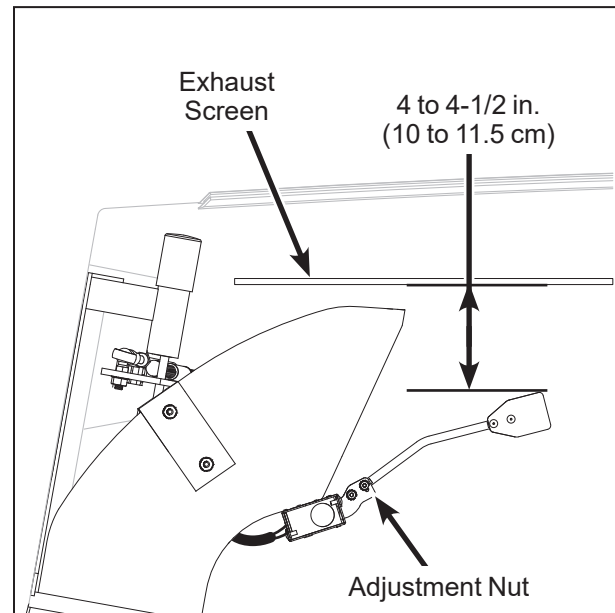

**Adjusting the Grass-Pak[®] Switch
(Side View of Catcher Box)**

3. If adjustment is required, loosen front adjustment nut then move aluminum shaft and vane to the recommended measurement. Adjustments should be done in very small increments checking the measurement each time until the recommended measurement is achieved.

NOTE: It will not be possible to adjust the switch to give a signal at the precise instant the catcher is full for a wide variety of mowing conditions. For example, wet heavy grass will fill the catcher differently than dry fluffy grass, causing the signal to come on a little sooner or later than usual. Primarily, the switch should be adjusted to give the “full” signal with a **little advance warning before overfilling and clogging** of the grass delivery chute begins (regardless of mowing conditions).

LIMITED WARRANTY FOR WALKER COMMERCIAL RIDER MOWER

1. WHAT THIS WARRANTY COVERS, AND FOR HOW LONG:

Walker Manufacturing company will, at its option, repair or replace, without charge, any part covered by this warranty which is found to be defective in material and/or workmanship within two (2) years* after the date of sale to the original retail purchaser unless the product is used for rental purposes, in which case this warranty is limited to ninety (90) days. At Walker's request, customer will make the defective part available for inspection by Walker and/or return the defective part to Walker, transportation charges prepaid. All parts and components of the Walker Mower are covered by this warranty **except** the following components which are warranted separately by their respective manufacturers:

Kohler Engine
Battery

The available warranties covering these items are furnished with each mower. Walker does not assume any warranty obligation, liability or modification for these items, which are covered exclusively by the stated warranty of the respective manufacturers noted above.

* Extended warranties are offered for the following powertrain components:

- A three (3) year unlimited hour warranty is offered for the Walker P/N 6200-9 Gear Axle Assembly.
- A three (3) year or 3000 hour (whichever comes first) warranty is offered for Eaton Model 7 Hydrostatic transmissions; covers full cost of replacement up to 1000 hours of use, and after 1000 hours warranty coverage is prorated against 3000 hours.

2. WHAT THIS WARRANTY DOES NOT COVER:

- A. This warranty does not cover defects caused by depreciation or damage caused by normal wear, accidents, improper maintenance, improper use or abuse of the product, alterations, or failure to follow the instructions contained in the Operator's Manual for operation and maintenance.
- B. The customer shall pay any charges for making service calls and/or for transporting the mower to and from the place where the inspection and/or warranty work is performed.

3. HOW TO OBTAIN SERVICE UNDER THIS WARRANTY:

Warranty service can be arranged by contacting the dealer where you purchased the mower or by contacting Walker Manufacturing Company, 5925 East Harmony Road, Ft. Collins, CO 80528. Proof of the date of purchase may be required to verify warranty coverage.

4. WARRANTY LIMITATION:

- A. **THERE IS NO OTHER EXPRESS WARRANTY. ANY WARRANTY THAT MAY BE IMPLIED FROM THIS PURCHASE INCLUDING MERCHANTABILITY AND FITNESS FOR A PARTICULAR PURPOSE IS HEREBY LIMITED TO THE DURATION OF THIS WARRANTY AND TO THE EXTENT PERMITTED BY LAW ANY AND ALL IMPLIED WARRANTIES ARE EXCLUDED.** Some states do not allow limitations on how long an implied warranty lasts, so the above limitations may not apply to you.
- B. **WALKER WILL NOT BE LIABLE FOR ANY INCIDENTAL, CONSEQUENTIAL, OR SPECIAL DAMAGES AND/OR EXPENSES IN CONNECTION WITH THE PURCHASE OR USE OF THE MOWER.** Some states do not allow the exclusion or limitation of incidental or consequential damages, so the above limitation(s) or exclusion(s) may not apply to you.
- C. Only the warranty expressed in this limited warranty shall apply and no dealer, distributor, or individual is authorized to amend, modify, or extend this warranty in any way. Accordingly, additional statements such as dealer advertising or presentations, whether oral or written, do not constitute warranties by Walker, and should not be relied upon.
- D. This warranty gives you specific legal rights, and you may also have other rights which vary from state to state.

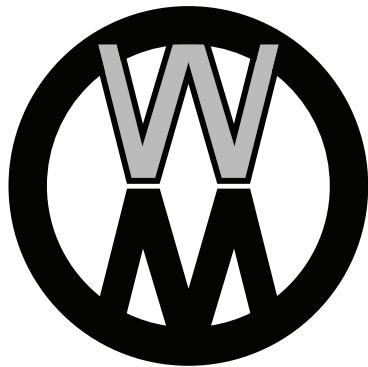

WALKER

WALKER MFG. CO. • 5925 E. HARMONY ROAD, FORT COLLINS, CO 80528 • (970) 221-5614
FORM NO. 020321 PRINTED IN USA www.walker.com ©2021 WALKER MFG. CO