

Operator's Manual



Air Mover
Model No.
AM201 0101

FOR YOUR SAFETY

Read and understand this manual before use.
Keep this manual for future reference.

TABLE OF CONTENTS

SECTION	PAGE
Warranty.....	2
Safety Instructions & Warnings.....	3
Grounding Instructions.....	4
Operation.....	5
Storage.....	8
Maintenance.....	9
Troubleshooting.....	10
Exploded View & Parts List.....	11

Thank you for purchasing this Vacmaster® air mover. Feel confident that with Vacmaster® you are obtaining a high-quality product engineered for optimal performance.

FOR YOUR SAFETY: CAREFULLY READ AND UNDERSTAND ALL INSTRUCTIONS.

WARRANTY

We take pride in producing a high-quality, durable product. This Vacmaster® product carries a limited two (2) year warranty against defects in workmanship and materials from date of purchase under normal household use. If product is to be used for commercial, industrial, or rental use, a 90 day limited warranty will apply. Please keep your receipt as proof of purchase. This warranty gives you specific legal rights, which may vary from state to state. For product service call Customer Service at 1-866-384-8432.

Not Covered by Warranty:

- Any part that has become inoperative due to misuse, negligence, direct/indirect abuse, accidents, improper maintenance, repairs, or alterations;
- Normal deterioration of the exterior finish due to use or exposure;
- Any product where serial number/data label is tampered with or removed;
- Any product purchased from an unauthorized retailer.

SAFETY INSTRUCTIONS & WARNINGS

IMPORTANT SAFETY INSTRUCTIONS

READ AND UNDERSTAND ALL INSTRUCTIONS BEFORE USING THIS AIR MOVER.

Read and understand this operator's manual and all labels on the air mover before operating. Safety is a combination of common sense, staying alert, and knowing how the air mover works. Use this air mover only as described in this manual.

SAVE THIS MANUAL FOR FUTURE REFERENCE.

WARNING: TO REDUCE THE RISK OF FIRE, ELECTRIC SHOCK, OR INJURY:

- Do not run air mover unattended.
- Do not use this air mover near flammable liquids, gases, or explosive vapors like gasoline or other fuels, lighter fluids, cleaners, oil-based paints, natural gas, hydrogen, or explosive dusts like coal dust, magnesium dust, grain dust, or gun power. Sparks inside the motor can ignite flammable vapors or dust.
- Use only with GFCI-protected outlets.
- Do not use an extension cord with this air mover.
- Do not use with a solid state speed control device.
- Do not expose to rain. Store indoors.
- Do not handle the plug or air mover with wet hands.
- Do not unplug by pulling on cord. To unplug, grasp the plug, not the cord.
- Do not pull or carry by cord, use cord as handle, close a door on cord, or pull cord around sharp edges or corners.
- Do not use with damaged cord, plug, or other parts.
- If air mover is not working as it should, or has been dropped, damaged, left outdoors, or dropped into water, take it to a service dealer for inspection and repair before using it again.
- To reduce the risk of health hazards from vapors or dusts, do not use or store near toxic or hazardous materials.
- Never operate this air mover with intake grills removed.
- Do not run cord under carpeting. Do not cover cord with rugs, runners, or other coverings. Direct cord away from traffic areas where it will not be tripped over.
- Do not put any object into intake openings. Do not operate air mover with any intake openings blocked.
- Do not allow to be used as a toy. Close attention is necessary when used by or near children.
- Direct air discharge at work area only; do not direct air at bystanders.
- Do not leave air mover unattended when plugged in.
- This air mover is equipped with an over-load protection device which may shut down the unit during operation. To reduce the risk of injury from accidental starting, turn off unit and unplug power cord when not in use or before servicing.
- Turn off air mover before unplugging.
- Keep hair, loose clothing, fingers, and all parts of body away from openings and moving parts.

SAFETY INSTRUCTIONS & WARNINGS

CAUTION:

- For dusty jobs, wear a dust mask.
- Do not move or carry the air mover while it is operating.
- Only operate on a level, stable surface to prevent the air mover from falling and potentially causing injury or damage to the unit or property.

Observe the following warnings that appear on the motor housing of this air mover:

WARNING:

- For your own safety, read and understand operator's manual.
- To reduce the risk of electric shock, do not expose to rain or water.
- Do not operate around explosive, toxic, carcinogenic, or hazardous materials, liquids, vapors, or dusts.
- Do not use an extension cord with this air mover.
- To reduce the risk of electric shock, connect only to an outlet provided with a ground fault circuit interrupting device.
- This is an automatically operated device - to reduce the risk of injury, disconnect from power supply before servicing.

GROUNDING INSTRUCTIONS

This appliance must be grounded. If it should malfunction or breakdown, grounding provides a path of least resistance for electric current to reduce the risk of electric shock. The plug must be inserted into an appropriate GFCI outlet that is properly installed and grounded in accordance with all local codes and ordinances.

This air mover is for use on a nominal 120-volt circuit, and has a grounded plug. The air mover should not be plugged into an outlet if it is not grounded and equipped with GFCI-equipped outlet. Please consult a qualified electrician if there is a question on whether an outlet is GFCI-equipped. Do not use with an extension cord.

CAUTION: RISK OF ELECTRIC SHOCK. THIS AIR MOVER IS SUPPLIED WITH A GROUNDING CONDUCTOR AND GROUNDING-TYPE ATTACHMENT PLUG. TO REDUCE THE RISK OF ELECTRIC SHOCK, BE CERTAIN THAT IT IS CONNECTED ONLY TO A GFCI-EQUIPPED, PROPERLY GROUNDED, GROUNDING-TYPE RECEPTACLE.

WARNING: CHECK WITH A QUALIFIED ELECTRICIAN OR SERVICE PERSON IF YOU ARE IN DOUBT AS TO WHETHER THE OUTLET IS PROPERLY GROUNDED. DO NOT MODIFY THE PLUG PROVIDED WITH THE APPLIANCE. IF IT WILL NOT FIT THE OUTLET, OR IF THE OUTLET IS NOT GFCI EQUIPPED, HAVE A PROPER GROUNDED, GFCI OUTLET INSTALLED BY A QUALIFIED ELECTRICIAN.

OPERATION

GETTING TO KNOW THE AIR MOVER

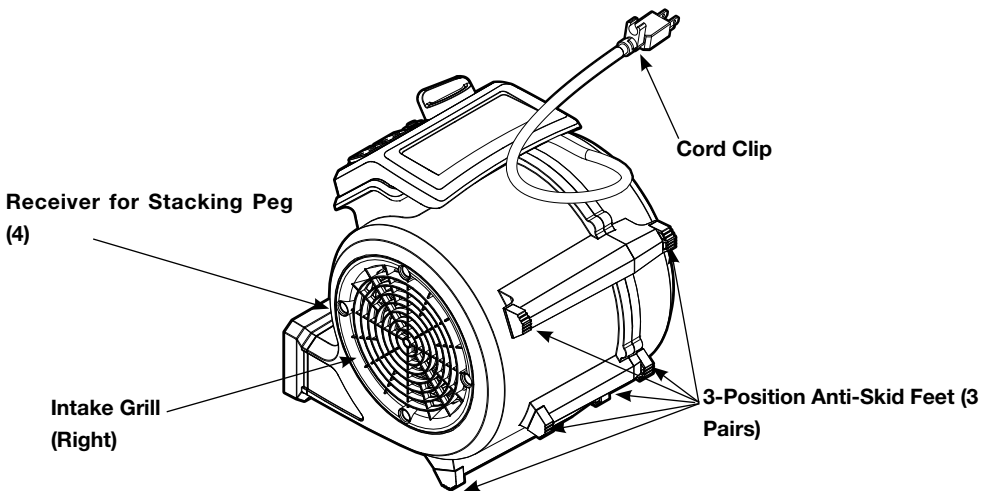
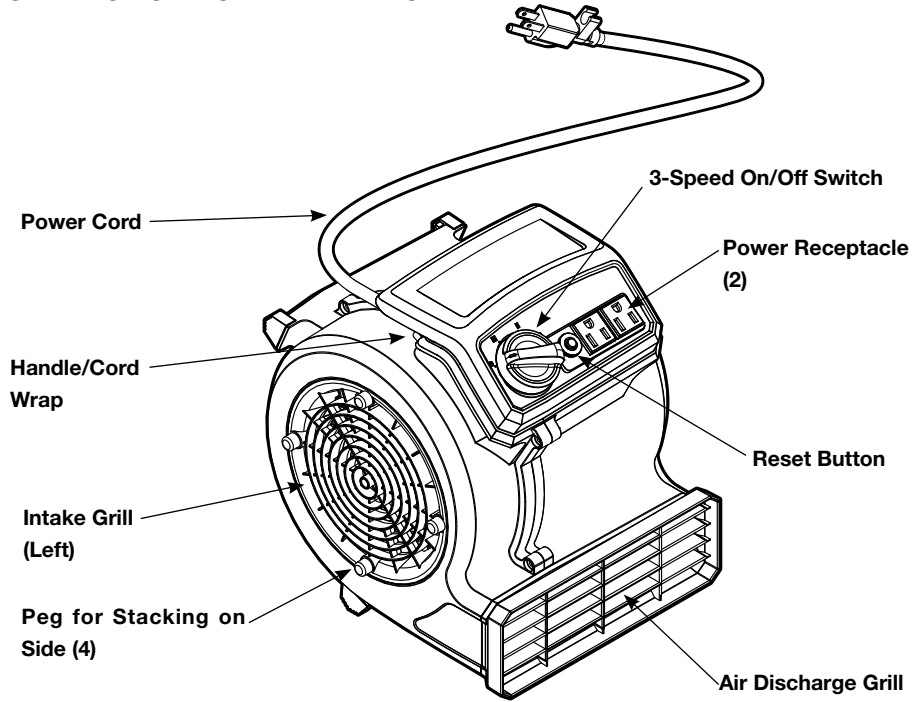

OPERATION

GENERAL USE INSTRUCTIONS

1. Verify that the 3-speed on/off switch is set to "0" (OFF) and the cord is unplugged.
2. Place the air mover in the desired position on a stable surface. Ensure there is at least a foot of clearance on each side of the air mover. Avoid placing the air mover where loose fabric, sheets, or other objects can get pulled onto the intake grills.
3. Direct air mover at the designated target area, using one of the operational positions listed on page 6.
4. Plug in the air mover to a grounded, GFCI-protected outlet. See page 4 for grounding instructions. **DO NOT USE WITH AN EXTENSION CORD.**
5. Turn on the air mover by rotating the 3-Speed On/Off Switch clockwise to the desired power level (I, II, or III).
6. The air mover is equipped with an overload protection feature. If the air mover is overloaded, it will shut off and will need to be reset before it can be used again. If this occurs, set the 3-speed on/off switch to "0" (OFF) and press the reset button. Check that there are no obstructions preventing airflow into the intake grills before turning on the air mover again.
7. When finished with use, turn the 3-speed on/off switch counter-clockwise to the "0" (OFF) position and unplug the power cord from the outlet. See page 8-9 for storage instructions.

WARNING: BE SURE TO READ, UNDERSTAND, AND APPLY, ALL THE INFORMATION IN THE IMPORTANT SAFETY INSTRUCTIONS SECTION AT THE BEGINNING OF THIS OPERATOR'S MANUAL. DO NOT OPERATE IN AREAS WITH FLAMMABLE GASES, VAPORS, OR EXPLOSIVE DUSTS IN THE AIR. FLAMMABLE GASES OR VAPORS INCLUDE BUT ARE NOT LIMITED TO: LIGHTER FLUID, SOLVENT TYPE CLEANERS, OIL-BASED PAINTS, GASOLINE, ALCOHOL, OR AEROSOL SPRAYS. EXPLOSIVE DUSTS INCLUDE BUT ARE NOT LIMITED TO: COAL, MAGNESIUM, GRAIN, OR GUN POWDER. TO REDUCE THE RISK OF HEALTH HAZARDS FROM VAPORS OR DUST, DO NOT USE AROUND TOXIC MATERIALS.

OPERATIONAL POSITIONS

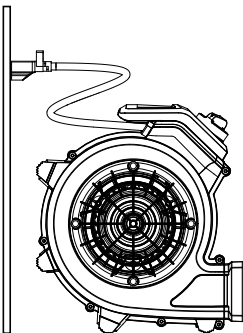

Carpet and Flooring

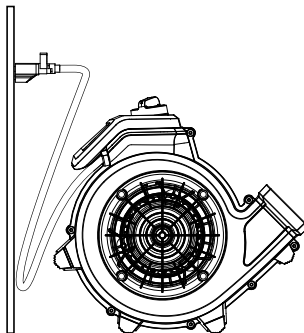

Stairs and Walls

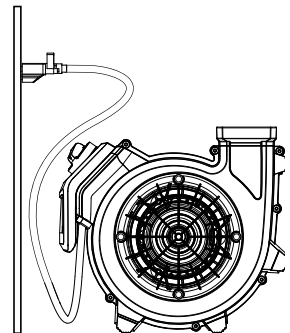

Ceilings

OPERATION

This air mover has the ability to connect up to three units together to maximize air circulation. To do this, plug the first unit into a grounded electrical outlet. Then plug a second unit into the receptacle of the first unit. A third unit can then be plugged into the receptacle of the second unit. (Other units sold separately.)

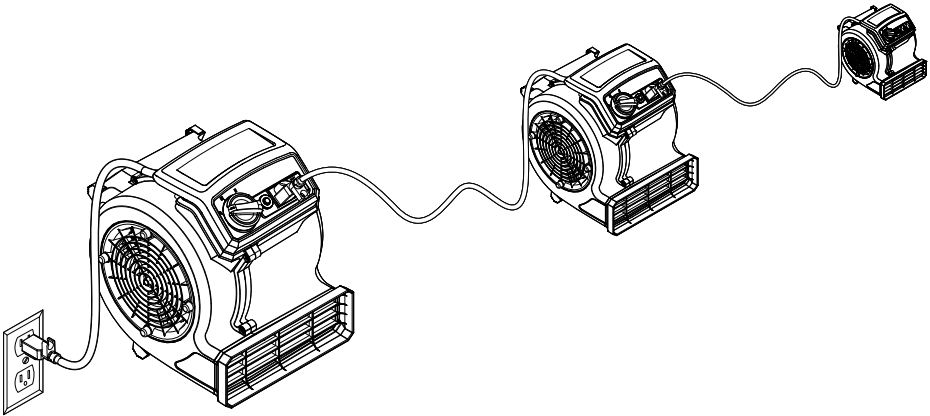

WARNING: Do not stack air movers vertically during operation. To reduce risk of overheating or overload, ensure area around intake grills are clear to allow for unobstructed air flow.

The total rated amperage for all units running through the unit plugged into the outlet should never exceed 10A. Do not use an extension cord to connect units, or to connect a unit to the wall outlet.

STORAGE

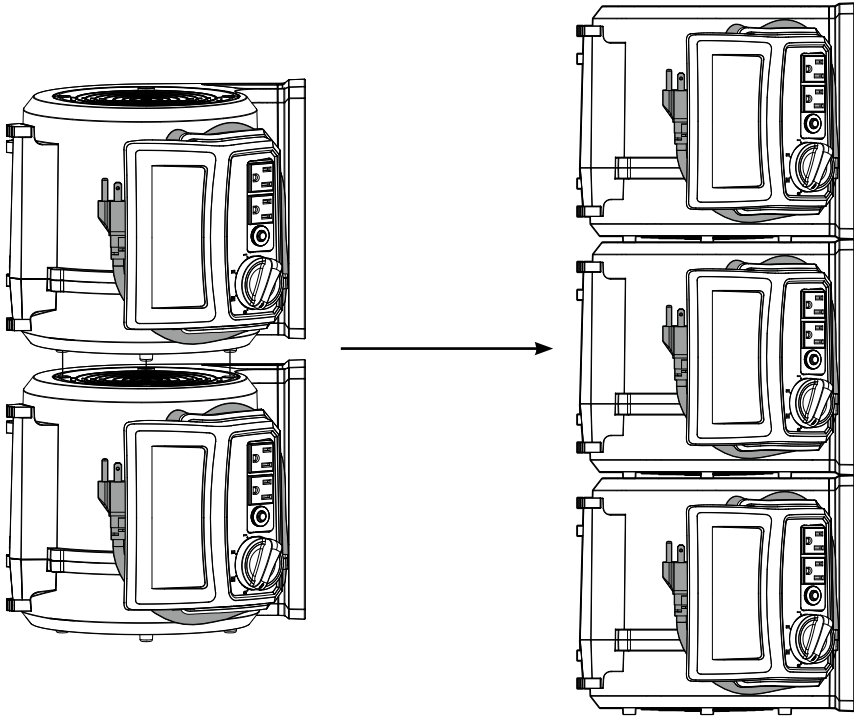

WARNING: DO NOT STORE OUTDOORS. STORE IN A DRY ENVIRONMENT, AWAY FROM HAZARDOUS MATERIALS, SUCH AS TOXIC, CARCINOGENIC, FLAMMABLE, OR EXPLOSIVE SUBSTANCES.

CAUTION: TO PREVENT DAMAGE TO AIR MOVER, PROPERTY DAMAGE, OR PERSONAL INJURY: DO NOT STACK MORE THAN THREE UNITS HIGH. STACK ONLY ON A STABLE, LEVEL, EVEN SURFACE. DO NOT TRANSPORT STACKED UNITS UNLESS THEY ARE BRACED ON ALL SIDES.

CAUTION: DO NOT TURN ON THE AIR MOVER WHILE IT IS STACKED. THE STACKING PEGS ARE FOR STORAGE PURPOSES ONLY.

CORD STORAGE

Before storing the air mover, ensure the power switch is turned to the OFF position, and unplug the unit from the power outlet.

Wrap the cord around the base of the handle.

Use the attached cord clip to hold the cord in place.

STORING THE AIR MOVER

To conserve space while storing multiple units, this air mover can be stacked together with multiple additional units, as illustrated above.

To stack, the pegs on the intake grill on the power switch side of the unit must be inserted into the peg receiver on the opposite side of the partner unit.

MAINTENANCE

WARNING: AFTER HAVING SERVICED, ENSURE ANY PROTECTIVE OR SAFETY DEVICES ARE REINSTALLED BEFORE USE, INCLUDING INTAKE GRILLS, AIR DISCHARGE GRILL AND IMPELLER.

Before and after each use:

Inspect the plug and the cord to ensure that it has not been damaged during operation or between uses; if the plug or cord is damaged, do not use the air mover and replace the damaged part immediately.

Check the air intake and air discharge grills and make sure they are free of blockage.

TROUBLESHOOTING

WARNING! TO REDUCE THE RISK OF ELECTRIC SHOCK, UNPLUG BEFORE TROUBLESHOOTING.

Problem	Possible Causes	Corrective Action
Air Mover will not operate.	1) No power supply.	1) Check power supply - cord, breakers, and fuses.
	2) Faulty power cord.	2) Unplug and check the power cord. If damaged, have it repaired by a professional.
	3) Switch in the wrong position.	3) Move switch to the "On" position (I, II, or III).
	4) Switch is faulty or burned out.	4) Have switch replaced by a professional.
	5) Overload protection has engaged, shutting off the air mover.	5) Ensure the switch is turned to the "Off" position (0) and press the reset button.
Air Mover runs but makes loud scraping noise.	1) Accident to unit has caused deformed housing or misaligned wheel.	1) Replace air mover.
Air Mover runs but blower wheel does not rotate.	1) Blower wheel and housing are jammed.	1-2) Replace air mover.
	2) There is a problem with the switch or capacitor.	
Air Mover runs briefly then shuts off due to overload protection.	1) Intake grill or air discharge grill is obstructed.	1) Remove obstruction.
	2) Motor is damaged or worn out.	2) Replace air mover.
Air Mover runs but with excessive vibration.	1) The blower wheel has dirt build up.	1-2) Have air mover inspected by a professional.
	2) The blower wheel is damaged or the motor is bent.	1) Have blower wheel cleaned by professional. 2) Replace air mover.

EXPLODED VIEW & PARTS

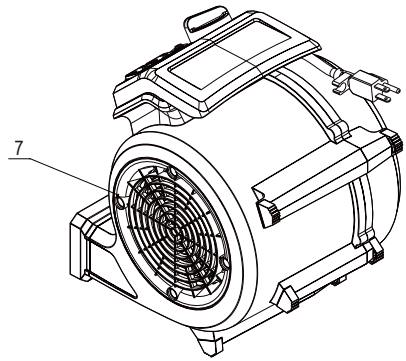
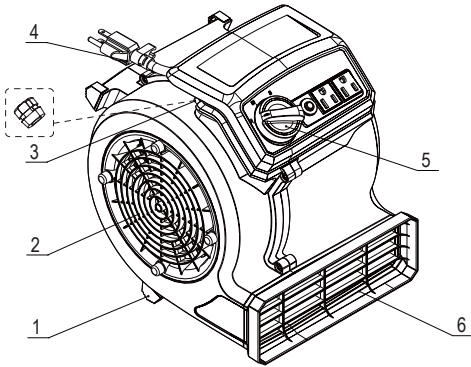

Key No.	Part Number	Description	Quantity
1	251002118	Rubber Foot	8
2	251002115	Intake Grill (Left)	1
3	251002113	Cord Grommet	1
4	251002111	Power Cord	1
5	251006101	ON/OFF Switch	1
6	251002117	Air Discharge Grill	1
7	251002120	Intake Grill (Right)	1