

# Genie®

## Operator's Manual

First Edition  
Seventh Printing  
Part No. 35566



Genie Lift™

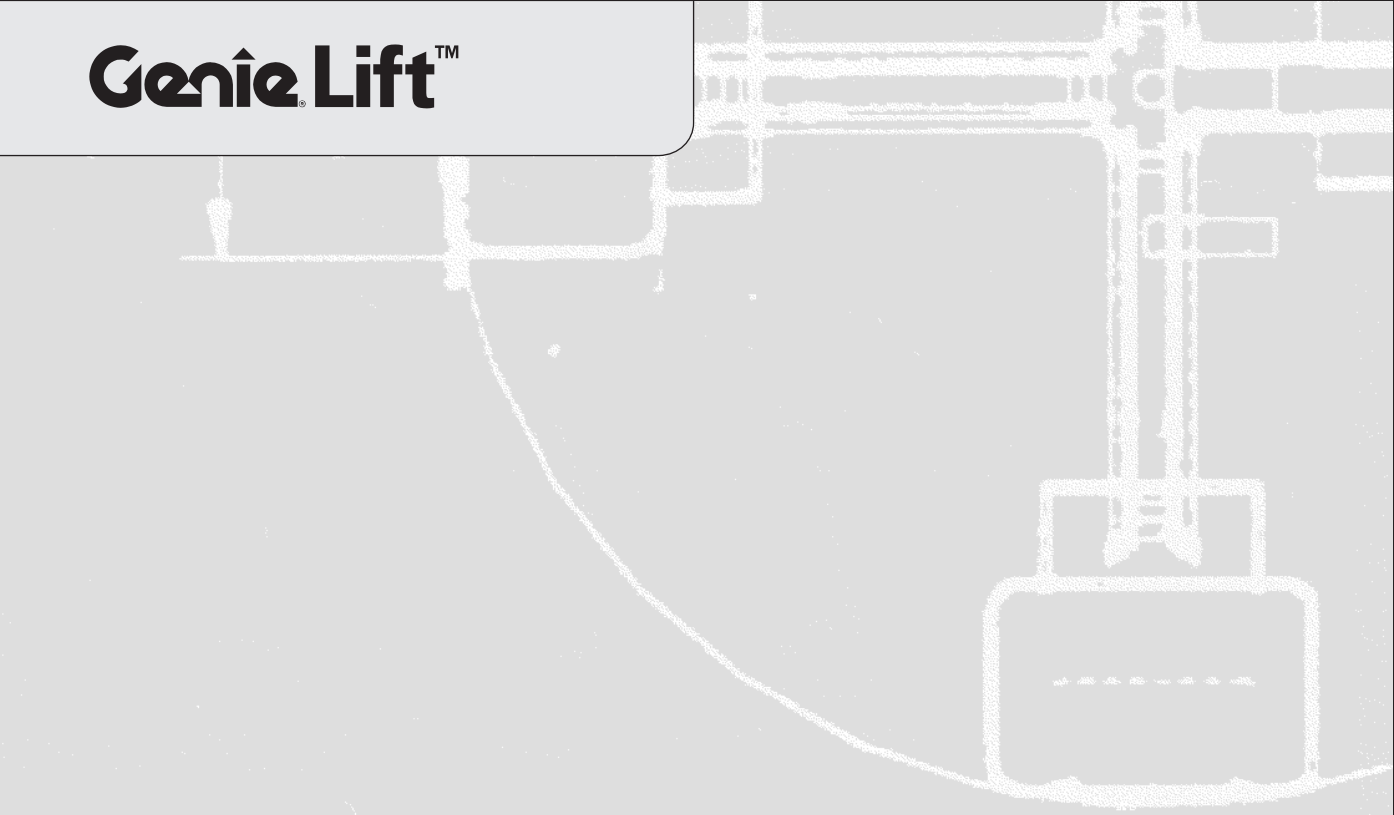

## Important

Read, understand and obey these safety rules and operating instructions before operating this machine. Only trained and authorized personnel shall be permitted to operate this machine. If you have any questions, call Genie Industries.

---

## Contents

	Page
Safety .....	1
Legend .....	6
Pre-operation Inspection .....	8
Function Tests .....	10
Workplace Inspection .....	13
Operating Instructions .....	14
Battery & Charger Operating Instructions .....	16
Transport Instructions .....	17
Load Capacity Charts .....	18
Decals .....	20
Specifications .....	22

---

## Contact us:

Internet: <http://www.genielift.com>  
 e-mail: [techpub@genieind.com](mailto:techpub@genieind.com)

---

Copyright © 1995 by Genie Industries

First Edition: Sixth Printing, December 2004

First Edition: Seventh Printing, August 2008

"Genie" is a registered trademark of Genie Industries in the USA and many other countries.

 Printed on recycled paper

Printed in U.S.A.

---

# Safety Rules



---

## Warning

Failure to obey the instructions and safety rules in this manual may result in death or serious injury.

---

## Do Not Operate Unless:

- You learn and practice the principles of safe machine operation contained in this operator's manual.
  - 1 Avoid hazardous situations.**
    - Know and understand the safety rules before going on to the next section.**
    - 2 Always perform a pre-operation inspection.
    - 3 Always perform the function tests prior to use.
    - 4 Inspect the workplace.
    - 5 Only use the machine as it was intended.
- You read, understand and obey the manufacturer's instructions and safety rules—safety and operator's manuals and machine decals.
- You read, understand and obey employer's safety rules and work site regulations.
- You read, understand and obey all applicable governmental regulations.
- You are properly trained to safely operate the machine.

## SAFETY RULES

**Fall Hazards**

Do not use as a personnel lifting platform or step.

Do not stand or sit on the forks, load platform or boom.

Do not climb on the machine.

**Tip-over Hazards**

Do not exceed the rated load capacity. See Load Capacity Charts section.

Do not raise the load unless the leg lock pins have been properly inserted into the legs.

Do not raise the load unless the correct length legs are properly installed.

Do not raise the load unless the machine is on a firm, level surface.



Do not move the machine with a raised load, except for minor positioning.

Do not tilt the machine back with a raised load.

Do not use blocks to level the machine.

Do not operate the machine in strong or gusty winds. Increasing the load surface area will decrease machine stability in windy conditions.

Do not place ladders or scaffolding against any part of the machine.

Do not operate the machine unless the wheel / leg / caster configuration is properly installed.

Prior to use, check the work area for drop-offs, holes, bumps, debris, unstable or slippery surfaces or other possible hazardous conditions.

Avoid debris and uneven surfaces while rolling a machine without the legs installed.

Do not replace machine parts critical to stability or structure with items of different weight or specification.

Do not cause a horizontal force or side load to the machine by raising or lowering a fixed or overhanging load.

Do not use the machine on a moving or mobile surface or vehicle.

**Collision Hazards**

Do not raise if the load is not properly centered on the forks or load platform.

Check the work area for overhead obstructions or other possible hazards.

Do not stand under or allow personnel under the machine when the load is raised.



Do not lower the load unless the area below is clear of personnel and obstructions.

Use common sense and planning when transporting the machine on an incline, slope or stairs.

Maintain proper lubrication on the frame channels. See the Pre-operation Inspection section. Unlubricated frame channels can bind or stop moving, which could result in the load shifting or falling.

SAFETY RULES

### Electrocution Hazards

This machine is not electrically insulated and will not provide protection from contact with or proximity to electrical current.

Maintain safe distances away from electrical power lines and apparatus in accordance with applicable governmental regulations and the following chart.

Voltage	Minimum Safe Approach Distance	
	Feet	Meters
Phase to Phase		
0 to 300V	Avoid Contact	
300V to 50KV	10	3.1
50KV to 200KV	15	4.6
200KV to 350KV	20	6.1
350KV to 500KV	25	7.6
500KV to 750KV	35	10.7
750KV to 1000KV	45	13.7

Allow for mast movement and electrical line sway or sag, and beware of strong or gusty winds.

Keep away from the machine if it contacts energized power lines. Personnel must not touch or operate the machine until power lines are shut off.

Do not use the machine as a ground for welding.

### Bodily Injury Hazards

Do not grasp the cable.

Keep hands and fingers away from the pulleys, carriage and other potential pinch points.

Do not place arms, hands or fingers through the frame.

### Improper Use Hazard

Never leave a machine unattended with a load. Unauthorized personnel may attempt to operate the machine without proper instruction, creating an unsafe condition.

### Damaged Machine Hazards



Do not use a damaged or malfunctioning machine.

Do not use a machine with a worn, frayed, kinked or damaged cable.

Do not use a machine with less than 4 wraps of cable on the winch drum when the carriage is fully lowered.

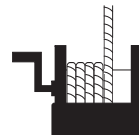

Conduct a thorough pre-operation inspection prior to each use.

Be sure that all decals are legible and in place.

Maintain proper lubrication on the winch. See *Genie Lift Parts and Service Manual* for details. Do not allow oil or grease on braking surfaces.

### Crushing Hazard

Maintain a firm grasp on the winch handle until the brake is locked. The brake is locked when the load will not cause the winch handle to turn.

### Lifting Hazard

Use proper lifting techniques to load or tip the machine, or move the machine on stairs.

Do not move the machine on stairs when the machine is equipped with the 4 point caster option.

## SAFETY RULES

**Ladder Safety****Fall Hazards**

Do not use the ladder as scaffolding.

Do not sit on the ladder.

Do not over reach. Keep your body centered between both side rails.

Do not use the top rung as a step.

**Tip-over Hazards**

Do not exceed the ladder's maximum capacity of 250 lbs / 113 kg.

Do not overload the ladder. Ladders are designed for 1 person only.

Do not use the ladder unless it is properly set up.

Do not shift the ladder while on it. Avoid pushing or pulling off to the side of the ladder.

Do not set up the ladder on slippery surfaces.

Do not use blocks to level the ladder.

**Electric Winch Safety****Electrocution Hazard**

Do not operate the DC battery charger unless using a 3-wire grounded extension cord connected to a grounded AC circuit. Do not alter or disable the 3-wire grounded plugs.

**Tip-over Hazards**

Do not exceed the rated load capacity. See Load Capacity Charts section.

Do not use the electric winch on models with the standard base. The electric winch is designed for use only on straddle base models.

Do not alter or disable the limit switch.

**Battery and Charger Safety  
- Electric Winch Models****Burn Hazards**

Batteries contain acid. Always wear protective clothing and eyewear when working with batteries.



Avoid spilling or contacting battery acid. Neutralize battery acid spills with baking soda and water.



The battery pack must remain in an upright position.

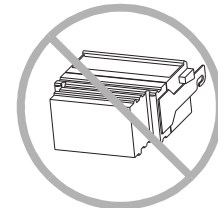

SAFETY RULES

### Explosion Hazards



Batteries emit explosive gas. Keep sparks, flames and lighted tobacco away from the battery.

Charge the battery in a well-ventilated area.

Do not disconnect the charger DC output wires from the battery when the charger is on.

### Electrocution Hazards



Connect the charger to a grounded AC circuit only.

Do not expose the battery or charger to water or rain.

Before each use, inspect for damage. Replace damaged components before operating.

### Lifting Hazard

The battery pack weighs 80 lbs / 37 kg. Use the appropriate number of people and proper lifting techniques when lifting the battery pack.

### Decal Legend

Genie product decals use symbols, color coding and signal words to identify the following:



Safety alert symbol—used to alert personnel to potential personal injury hazards. Obey all safety messages that follow this symbol to avoid possible injury or death.



Red—used to indicate the presence of an imminently hazardous situation which, if not avoided, will result in death or serious injury.



Orange—used to indicate the presence of a potentially hazardous situation which, if not avoided, could result in death or serious injury.



Yellow with safety alert symbol—used to indicate the presence of a potentially hazardous situation which, if not avoided, may cause minor or moderate injury.



Yellow without safety alert symbol—used to indicate the presence of a potentially hazardous situation which, if not avoided, may result in property damage.



Green—used to indicate operation or maintenance information.

# Legend

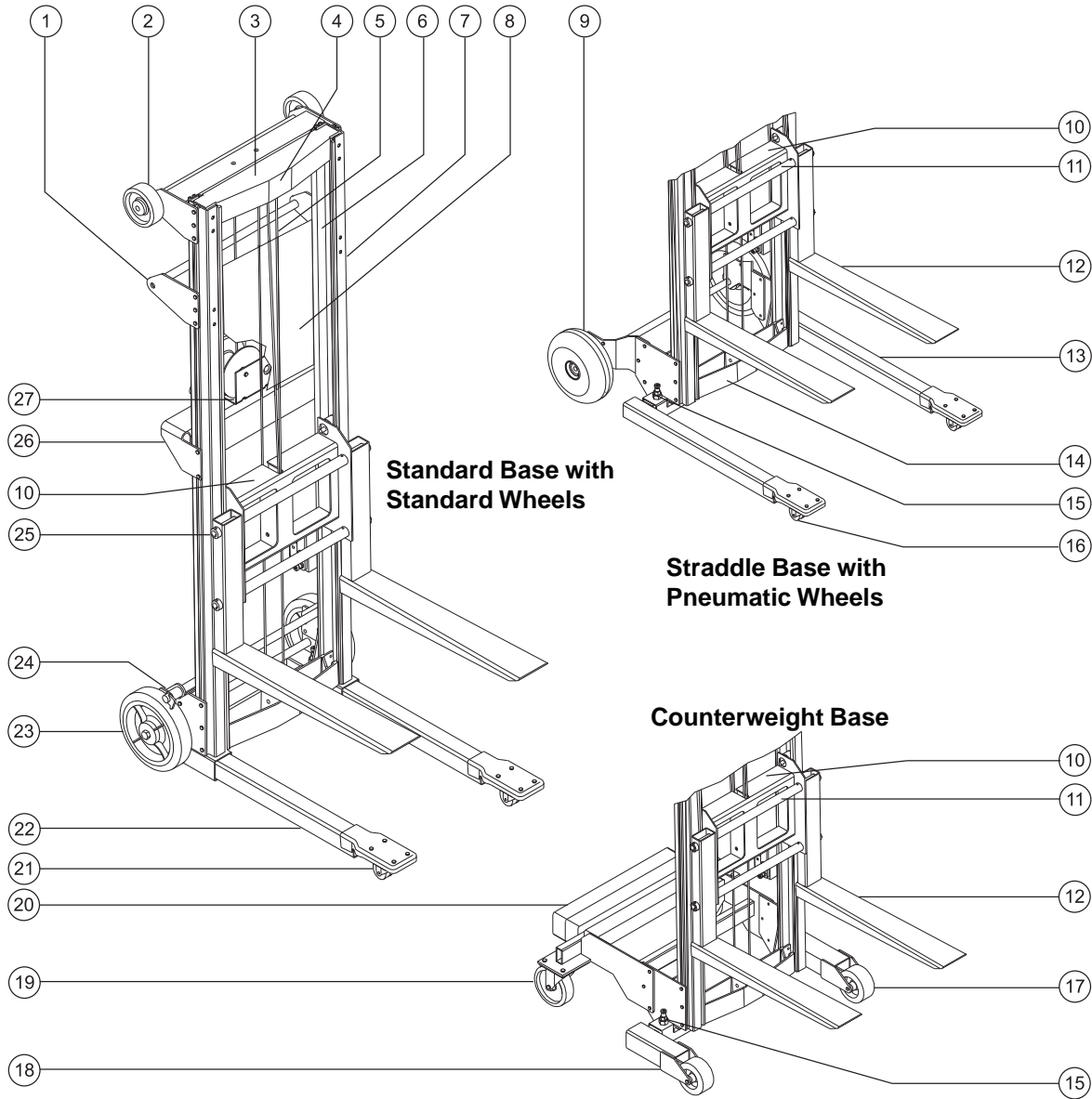

- |                            |   |  |
|----------------------------|---|--|
| 1 Handle                   | 10 Carriage   | 17 Wheel - 4 inch fixed                |
| 2 Loading wheels           | 11 Fork mounting tube   | 18 Adjustable leg - counterweight base |
| 3 Upper inner frame pulley | 12 Fork   | 19 Caster - 5 inch swivel              |
| 4 Cable anchor             | 13 Adjustable leg - straddle base                             | 20 Counterweight base                  |
| 5 Cable                    | 14 Lower inner frame pulley                                   | 21 Caster - 2 inch dual wheel          |
| 6 Inner frame              | 15 Leg lock pin   | 22 Leg - standard base                 |
| 7 Outer frame              | 16 Caster, 2 inch - option A<br>Caster, 2 1/2 inch - option B | 23 Solid rubber wheel                  |
| 8 Decal plate              |   |  |
| 9 Pneumatic wheel          |   |  |



LEGEND

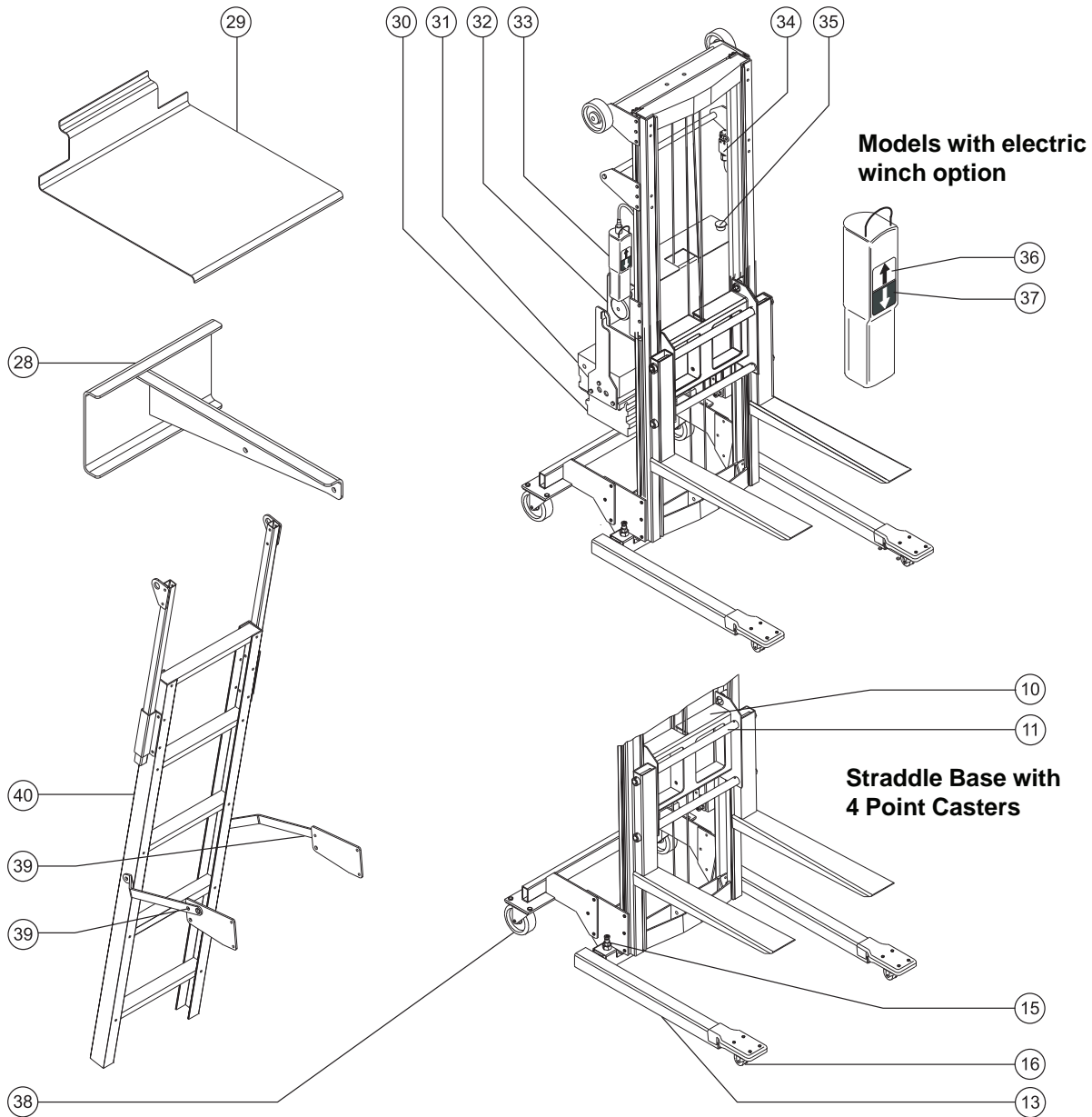

- |                           |                                     |   |
|---------------------------|-------------------------------------|---|
| 24 Brake (option)         | 31 Electric winch charger           | 37 Electric winch control down button                     |
| 25 Fork lock pin          | 32 Electric winch (option)          | 38 Caster, 4 inch - option A<br>Caster, 5 inch - option B |
| 26 Winch mounting bracket | 33 Electric winch control           | 39 Ladder snap pin  |
| 27 Winch                  | 34 Electric winch limit switch      | 40 Ladder (option)  |
| 28 Boom (option)          | 35 Red Emergency Stop button        |   |
| 29 Load platform (option) | 36 Electric winch control up button |   |
| 30 Electric winch battery |                                     |   |

---

# Pre-operation Inspection



## Do Not Operate Unless:

---

You learn and practice the principles of safe machine operation contained in this operator's manual.

1 Avoid hazardous situations.

**2 Always perform a pre-operation inspection.**

**Know and understand the pre-operation inspection before going on to the next section.**

3 Always perform function tests prior to use.

4 Inspect the workplace.

5 Only use the machine as it was intended.

## Fundamentals

The pre-operation inspection is a visual inspection performed by the operator prior to each work shift. This inspection is designed to discover if anything is apparently wrong with a machine before the operator tests it.

Refer to the list on the next page and check each of the items.

If damage or any unauthorized variation from factory delivered condition is discovered, the machine must be tagged and removed from service.

Repairs to the machine may only be made by a qualified service technician, according to the manufacturer's specifications. After repairs are completed, the operator must perform a pre-operation inspection again before testing the machine functions.

## PRE-OPERATION INSPECTION

## Pre-operation Inspection

---

- Be sure that the operator's manual is complete, legible and available for reference.
- Be sure that all decals are legible and in place. See Decals section.

Check the following components or areas for damage, improperly installed or missing parts and unauthorized modifications:

- Winch and related components
- Base components
- Legs
- Roller wheels
- Inner and outer frames
- Glide buttons
- Carriage hold-down assembly
- Cable anchor
- Cable and pulleys
- Wheels and casters
- Forks
- Load platform and boom (if equipped)
- Nuts, bolts and other fasteners
- Cable (kinks, frays, abrasions)
- Ladder (if equipped)
- Brake system (if equipped)
- Limit switch (electric winch models)
- Electric winch and related components (if equipped)
- Hand controls and wiring (electric winch models)

Check the entire machine for:

- Dents or damage
- Corrosion or oxidation
- Cracks in welds or structural components
- Be sure that all structural and other critical components are present and all associated fasteners and pins are in place and properly tightened.
- Inspect and clean the battery terminals and all battery cable connections.
- Be sure there is a minimum of 4 wraps of cable around the winch drum when the carriage is fully lowered.
- Be sure the frame channels are properly lubricated and free of debris. Lubricate the channels with a dry silicone spray or silicone wax (Genie part number 90337).

# Function Tests



## Do Not Operate Unless:

---

- You learn and practice the principles of safe machine operation contained in this operator's manual.
- 1 Avoid hazardous situations.
- 2 Always perform a pre-operation inspection.
- 3 Always perform function tests prior to use.**

## Know and understand the function tests before going on to the next section.

- 4 Inspect the workplace.
- 5 Only use the machine as it was intended.

## Fundamentals

The function tests are designed to discover any malfunctions before the machine is put into service. The operator must follow the step-by-step instructions to test all machine functions.

A malfunctioning machine must never be used. If malfunctions are discovered, the machine must be tagged and removed from service. Repairs to the machine may only be made by a qualified service technician, according to the manufacturer's specifications.

After repairs are completed, the operator must perform a pre-operation inspection and function tests again before putting the machine into service.

## FUNCTION TESTS

## Function Tests

---

- 1 Select a test area that is firm, level and free of obstructions.

### Setup

- 1 Tilt the machine back.
- 2 Slide each fork onto the carriage and secure it with the fork lock pins.
- 3 Slide each leg into a base socket until the leg lock pin snaps into the leg. 
- 4 Stand the machine up.
- 5 Remove the winch handle, reverse the handle and install it. The handle grip should face the operator.
- 6 **Straddle base:** Adjust to desired width. Be sure the leg lock pin snaps into the leg.
- 7 Rotate the hold-down bar off of the carriage.

### Boom

- 1 Hold the boom in a vertical position.
- 2 Place the top of the boom plate under the upper fork mounting tube and lift up.
- 3 Rotate the boom down until it locks into place.
- 4 Attach the lifting shackle to the desired hole on the boom.

### Load Platform

- 1 Lay the load platform onto the forks.
- 2 Lift the front of the load platform and push it toward the carriage until the back angle is under the lower fork mounting tube.
- 3 Rotate the load platform down until it locks into place over the forks.

### Ladder Setup (if equipped)

- 1 Position the machine.
- 2 Pull the snap pins on both sides of the ladder.
- 3 Pull the ladder down into the lowered position. Be sure to support the ladder until it is fully lowered.

To store the ladder: Raise the ladder to the stowed position and be sure the snap pins lock into place.

## FUNCTION TESTS

**Test the Brake Operation  
(if equipped)**

- 1 Press down on the foot pedal to lock the brake.
- 2 Push the machine.
- ⦿ Result: The wheels should not roll.
- 3 Pull up on the foot pedal to release the brake.
- 4 Push the machine.
- ⦿ Result: The machine should move.

**Test the Winch Operation**

Note: The Genie Lift 4 does not have an inner frame.

- 1 Rotate the winch handle clockwise to raise the carriage.
- ⦿ Result: The carriage should raise to the top of the inner frame and then the inner frame should raise. The carriage and inner frame should move smoothly, free of hesitation and binding.
- 2 Rotate the winch handle counterclockwise to lower the carriage.
- ⦿ Result: The inner frame should lower into the outer frame, and then the carriage should lower into the inner frame. The carriage and inner frame should move smoothly, free of hesitation and binding.

Note: If the carriage and inner frame do not move freely, the channels may need to be lubricated with a dry silicone spray or silicone wax.

**Test Electric Winch Operation  
(if equipped)**

Note: The Genie Lift 4 does not have an inner frame.

- 1 Connect the battery pack.
- 2 Pull out the red Emergency Stop button to the on position.
- 3 Push the up button on the hand controls.
- ⦿ Result: The carriage should raise to the top of the inner frame and then the inner frame should raise. The carriage and inner frame should move smoothly, free of hesitation and binding. The winch should turn off when the carriage reaches maximum height.
- 4 Push in the red Emergency Stop button to the off position.
- 5 Push the down button, then the up button.
- ⦿ Result: The up/down function should not operate.

---

# Workplace Inspection



## Do Not Operate Unless:

---

You learn and practice the principles of safe machine operation contained in this operator's manual.

- 1 Avoid hazardous situations.
- 2 Always perform a pre-operation inspection.
- 3 Always perform function tests prior to use.
- 4 **Inspect the workplace.**

**Know and understand the workplace inspection before going on to the next section.**

- 5 Only use the machine as it was intended.

Be aware of and avoid the following hazardous situations:

- drop-offs or holes
- bumps and floor obstructions
- debris
- overhead obstructions and high voltage conductors
- hazardous locations
- sloped surfaces
- unstable or slippery surfaces
- inadequate surface support to withstand all load forces imposed by the machine
- wind and weather conditions
- all other possible unsafe conditions

## Fundamentals

The workplace inspection helps the operator determine if the workplace is suitable for safe machine operation. It should be performed by the operator prior to moving the machine to the workplace.

It is the operator's responsibility to read and remember the workplace hazards, then watch for and avoid them while moving, setting up and operating the machine.

# Operating Instructions



## Do Not Operate Unless:

- You learn and practice the principles of safe machine operation contained in this operator's manual.
- 1 Avoid hazardous situations.
- 2 Always perform a pre-operation inspection.
- 3 Always perform function tests prior to use.
- 4 Inspect the workplace.
- 5 **Only use the machine as it was intended.**

## Fundamentals

The Operating Instructions section provides instructions for each aspect of machine operation. It is the operator's responsibility to follow all the safety rules and instructions in the operator's manual.

Using the machine for any purpose other than lifting material is unsafe.

If more than one operator is expected to use a machine at different times in the same work shift, each operator is expected to follow all safety rules and instructions in the operator's manual. That means every new operator should perform a pre-operation inspection, function tests and a workplace inspection before using the machine.

## Setup

Select an area that is firm, level and free of obstructions.

Follow the Setup procedures in the Function Tests section.

## Raising and Lowering Load - Manual Winch

- 1 Center the load on the forks or load platform.
- 2 Raise the load by firmly grasping the winch handle and rotating it clockwise. Do not allow the cable to wind unevenly onto the winch drum.
- 3 Lower the load by firmly grasping the winch handle and rotating it counterclockwise. After lowering to the desired position, turn the winch handle clockwise (raise the load)  $\frac{1}{4}$  turn to set the brake.

## Raising and Lowering Load - Electric Winch

- 1 Center the load on the forks or load platform.
- 2 Connect the battery pack.
- 3 Pull out the red Emergency Stop button to the on position.
- 4 Push the up or down button on the hand controls for the desired direction of travel.



## OPERATING INSTRUCTIONS

## Moving Machine with a Load

It is best to move the machine on the work site with no load. Moving a raised load should be restricted to positioning for loading and unloading. If it is necessary to move the machine with a raised load, understand and obey the following safety rules:

- Make sure the area is level and clear of obstructions.
- Make sure the load is centered on the forks or load platform.
- Avoid sudden starts and stops.
- Travel with the load in the lowest possible position.
- Keep personnel away from the machine and load.
- Do not tilt the machine back with a raised load.

## Moving Machine on Stairs

It is best to move the machine on stairs using the optional stair glides. Moving the machine on stairs without the use of stair glides is not recommended. If it is necessary to move the machine on stairs, understand and obey the following safety rules:

- Do not move the machine on stairs when the machine is equipped with the 4 point caster option.
- Fully lower the load.
- Ease the machine over each stair. Maintain a firm grasp on the handle.
- Do not allow the machine to become unbalanced.
- Continue carefully up or down the stairs.
- Use the appropriate number of people and proper lifting techniques with heavy loads.
- Models with electric winch: Remove the battery pack.

## After Each Use

To prepare the machine for storage, remove the forks and legs and reverse the winch handle. Refer to the Setup procedure.

Select a safe storage location - firm level surface, weather protected, clear of obstruction and traffic.

Models with electric winch: Recharge the battery.

## OPERATING INSTRUCTIONS



## Battery and Charger Instructions

---

### Observe and Obey:

- Do not use an external charger or booster battery.
- Charge the battery in a well-ventilated area.
- Use proper AC input voltage for charging as indicated on the charger.
- Use only a Genie authorized battery and charger.

### To Charge Battery

- 1 Open the battery pack lid to access the battery.
- 2 Remove the battery vent caps and check the battery acid level. If necessary, add only enough distilled water to cover the plates. Do not overfill prior to the charge cycle.
- 3 Replace the battery vent caps.
- 4 If equipped: Set the power switch to the OFF position. Be sure that the DC output cord is properly connected to the battery (black to negative, red to positive).
- 5 Connect the battery charger to a grounded AC circuit.
- 6 If equipped: Set the AC Selector switch to the proper voltage.
- 7 Set the power switch to the AUTO position.
- 8 Monitor the ampere meter for the correct charge rate. The initial charge rate should be approximately 10A. The charge rate will decrease as the battery reaches full charge.

- 9 Charger models equipped with manual/auto selector switch: If the ampere meter indicates that the battery is not being charged, set the power switch to the MANUAL position until the ampere meter begins to move up the scale. Then set the power switch to the AUTO position.
- 10 The charger will turn off automatically when the battery is fully charged. If equipped: Set the power switch to the OFF position, then disconnect from the AC supply.
- 11 Check the battery acid level when the charge cycle is complete. Replenish with distilled water to the bottom of the fill tube. Do not overfill.

### Dry Battery Filling and Charging Instructions

- 1 Remove the battery vent caps and permanently remove the plastic seal from the battery vent openings.
- 2 Fill each cell with battery acid (electrolyte) until the level is sufficient to cover the plates.

Do not fill to maximum level until the battery charge cycle is complete. Overfilling can cause the battery acid to overflow during charging. Neutralize battery acid spills with baking soda and water.

- 3 Install the battery vent caps.
- 4 Charge the battery.
- 5 Check the battery acid level when the charging cycle is complete. Replenish with distilled water to the bottom of the fill tube. Do not overfill.

## OPERATING INSTRUCTIONS



## Transport Instructions

---

### Observe and Obey:

- Be sure the vehicle capacity and loading surfaces are sufficient to support the machine weight. See the serial plate for the machine weight.
- The transport vehicle must be parked on a level surface.
- Remove the load from the forks, boom or load platform before loading for transport.
- The transport vehicle must be secured to prevent rolling while the machine is being loaded.
- The machine must be securely fastened to the transport vehicle.

## Lifting Instructions

The number of people required to load and unload a machine is dependent on a number of factors, including but not limited to:

- the physical condition, strength and disabilities or prior injuries of the people involved
- the vertical and horizontal distances the machine has to be moved
- the number of times the machine will be loaded or unloaded
- the stance, posture and grip used by the people involved
- the lifting techniques used
- the site conditions and weather in which the activity is being performed (i.e., slippery, icy, raining)

The appropriate number of people and proper lifting techniques must be used to prevent physical injury.

## Loading for Transport

- 1 Fully lower the carriage.
- 2 Rotate the carriage hold-down bar over the carriage. Be sure the lock pin snaps into place.
- 3 Remove the winch handle, reverse the handle and install it. The handle grip should face the carriage.
- 4 Models with electric winch: Remove the battery pack.

# Load Capacity Charts



## Observe and Obey:

- ☑ Failure to properly position the load may result in death or serious injury.
- ☑ Verify that the load you wish to raise does not exceed the maximum load for your load center. See the load capacity charts on the next page.

**WARNING** Tip-over hazard. Raising a load that exceeds the machine capacity may result in death or serious injury.

- ☑ A load center is defined as the balancing point (center of gravity) of a load and must be positioned within the load center zone.

**WARNING** Tip-over hazard. Failure to position the load center within the load center zone may result in death or serious injury.

## Forks

### Load Positioning Instructions

- 1 Determine the weight of the load and the location of its load center.
- 2 Measure to the load center from the side of the load that will be closest to the carriage.
- 3 Refer to the chart on the next page to determine if the machine is capable of lifting the weight at the location on the forks.
- 4 Place the load so that it rests on the forks, as close to the carriage as possible.
- 5 Position the load so that the load center is within the load center zone.

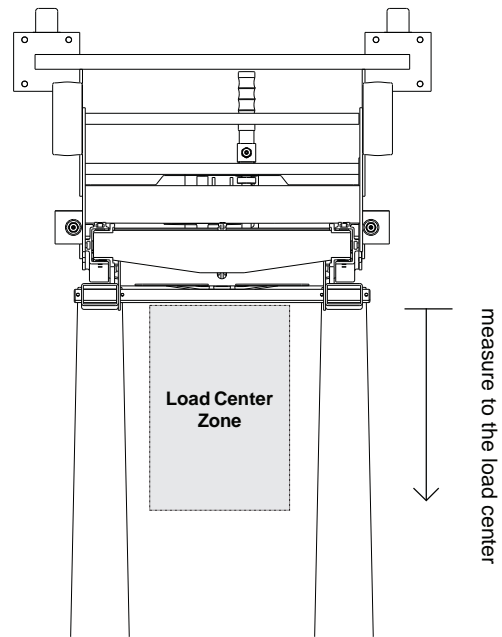

LOAD CAPACITY CHARTS

Forks Load Capacity Chart				
		inches	12	14
		cm	30	35
Model				
GL-4	lbs		500	500
	kg		227	227
GL-8	lbs		400	400
	kg		181	181
GL-10	lbs		350	350
	kg		159	159
GL-12	lbs		350	350
	kg		159	159

### Maximum Load Centers

(measure from front of carriage)

Forks:	14 in	35 cm
Load Platform:	14 in	35 cm
Boom:	20 in	51 cm

## Boom

### Load Positioning Instructions

- 1 Determine the weight of the load and the location of its load center.
- 2 Refer to the chart below to determine if the machine is capable of lifting the weight at the location on the boom.
- 3 Attach the lifting shackle to the desired hole on the boom.

Boom Load Capacity Chart				
Model		Front Hole	Rear Hole	
GL-4	lbs	300	500	
	kg	136	227	
GL-8	lbs	240	400	
	kg	109	181	
GL-10	lbs	210	350	
	kg	95	159	
GL-12	lbs	210	350	
	kg	95	159	

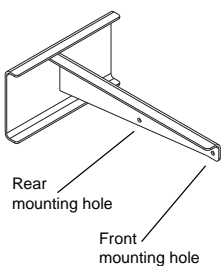

# Decals

## Inspection for Decals with Words

Determine whether the decals on your machine have words or symbols. Use the appropriate inspection to verify that all decals are legible and in place.

Part No.	Description	Quantity
33468	Warning - No Riders	1
35567	Warning - Bodily Injury Hazard	1
35574	Warning - Machine Safety and Setup	1
35575	Notice - Boom Setup	1
35577	Notice - Max Capacity 350 lbs / 159 kg, GL-10, GL-12	1
35578	Notice - Max Capacity 400 lbs / 181 kg, GL-8	1

Part No.	Description	Quantity
35579	Notice - Max Capacity 500 lbs / 227 kg, GL-4	1
37049	Warning - Tip-over Hazard	1
37084	Notice - Load Platform Setup	1
37111	Warning - Ladder Safety and Setup	1
37120	Warning - No Step	1
43021	Warning/Notice - Electric Winch Safety	1
43022	Danger/Notice - Electric Winch Battery Safety	1
52982	Cosmetic - Genie Lift	1
82959	Danger - Electrocutation Hazard	1
97529	Caution - Bodily Injury Hazard	1

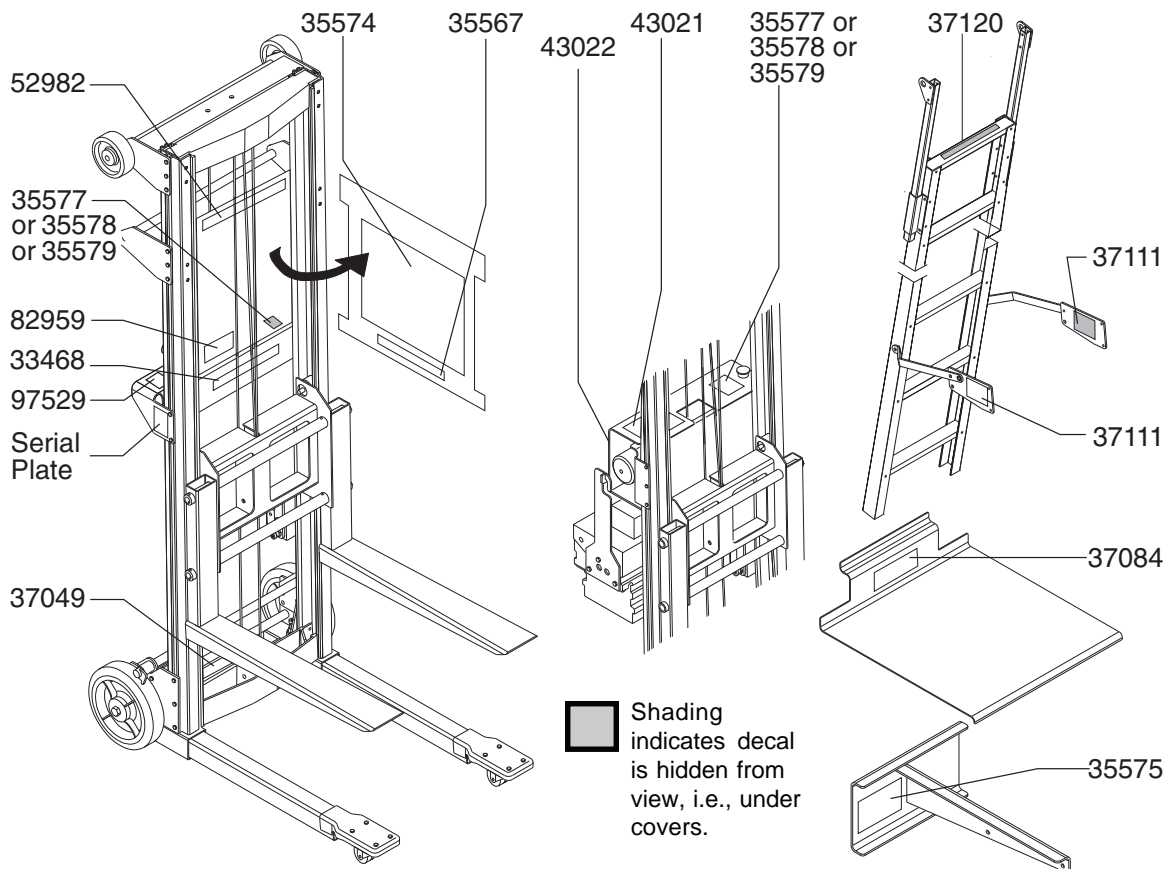

DECALS

### Inspection for Decals with Symbols

Determine whether the decals on your machine have words or symbols. Use the appropriate inspection to verify that all decals are legible and in place.

Part No.	Description	Quantity
52982	Cosmetic - Genie Lift	1
82481	Danger - Battery Safety	1
82962	Warning - No Riders	1
82487	Label - Read the Manual	3

Part No.	Description	Quantity
97510	Warning - Boom Setup	1
97511	Warning - Max Capacity 159 kg, GL-10, GL-12	1
97512	Warning - Max Capacity 181 kg, GL-8	1
97513	Warning - Max Capacity 227 kg, GL-4	1
97532	Caution - Bodily Injury Hazard	1
97533	Warning - No Step	2
97536	Warning - Do Not Reach	1
97539	Danger - Electrocutation Hazard	2
97540	Warning - Ladder Capacity, 113 kg	2

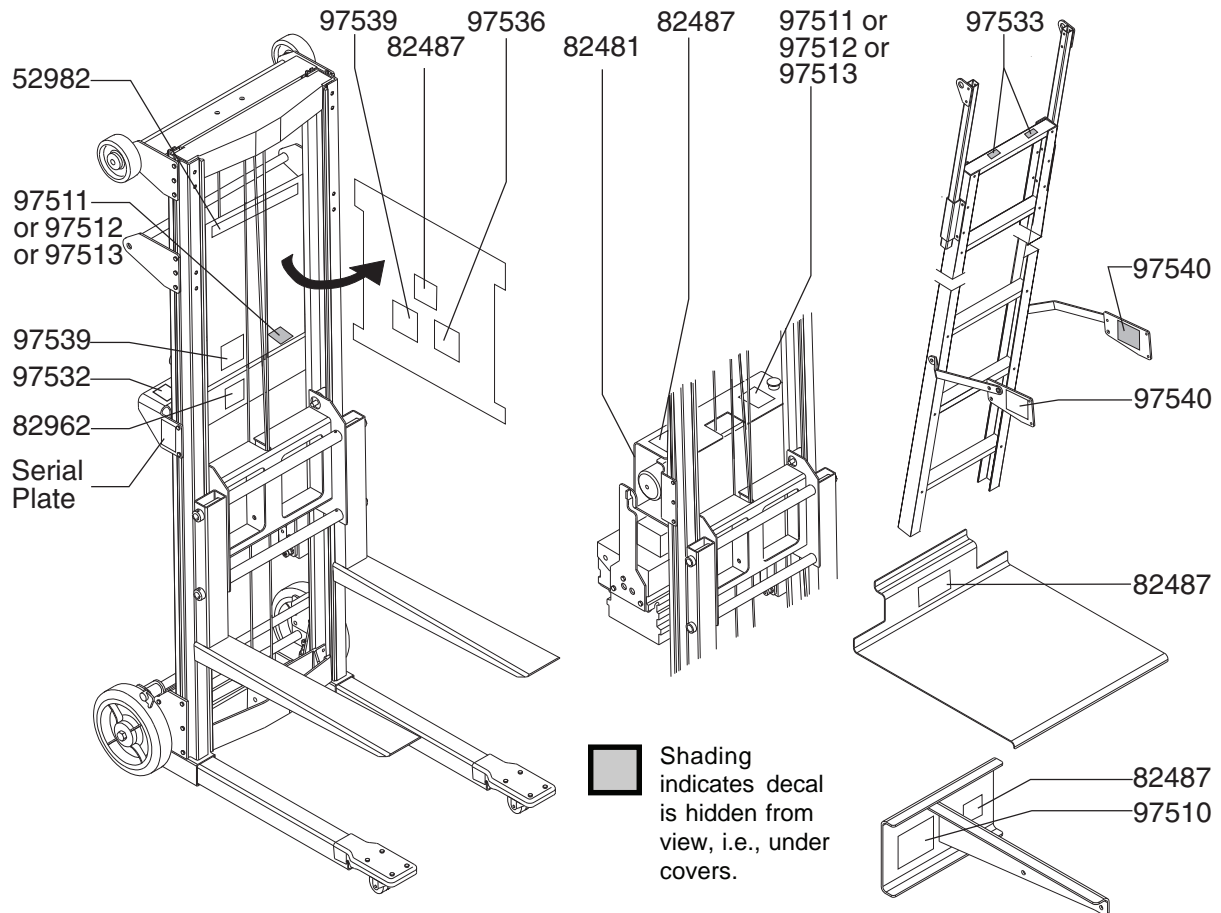

# Specifications

Model	GL-4	GL-8	GL-10	GL-12
<b>Height, maximum lift Forks up</b>	5 ft 11 in 1.8 m	10 ft 1/2 in 3.06 m	11 ft 8 in 3.6 m	13 ft 9 1/2 in 4.2 m
<b>Height, maximum lift Forks down</b>	4 ft 1 1/2 in 1.2 m	8 ft 3 in 2.5 m	9 ft 10 1/2 in 3 m	12 ft 3.7 m
<b>Height, minimum lift Forks down</b>	3 1/2 in 8.9 cm	3 1/2 in 8.9 cm	2 in 5.1 cm	2 in 5.1 cm
<b>Lift capacity at 12 in / 30.5 cm load center</b>	500 lbs 227 kg	400 lbs 181 kg	350 lbs 159 kg	350 lbs 159 kg
<b>Machine weight</b>	<b>See specification chart on next page.</b>			
<b>Height, stowed*</b>	5 ft 7 1/2 in 1.7 m	5 ft 7 1/2 in 1.7 m	6 ft 5 1/2 in 2 m	7 ft 6 3/4 in 2.3 m
<b>Ground clearance*</b>	3/4 in 1.9 cm	3/4 in 1.9 cm	3/4 in 1.9 cm	3/4 in 1.9 cm
<b>Standard base</b>				
Width	24 3/4 in 62.9 cm	24 3/4 in 62.9 cm	NA	NA
Length - stowed	12 in 30.5 cm	12 in 30.5 cm	NA	NA
Length - operating	34 3/4 in 88.3 cm	34 3/4 in 88.3 cm	NA	NA
<b>Straddle base</b>				
Width - stowed	28 3/4 in 73 cm	28 3/4 in 73 cm	28 3/4 in 73 cm	28 3/4 in 73 cm
Width - extended	43 1/2 in 1.1 m	43 1/2 in 1.1 m	43 1/2 in 1.1 m	43 1/2 in 1.1 m
Length - stowed	19 1/4 in 48.9 cm	19 1/4 in 48.9 cm	19 1/4 in 48.9 cm	19 1/4 in 48.9 cm
Length - operating	43 in 1 m	43 in 1 m	43 in 1 m	43 in 1 m
<b>Counterweighted base</b>				
Width - stowed	28 3/4 in 73 cm	28 3/4 in 73 cm	28 3/4 in 73 cm	NA
Width - extended	43 1/2 in 1.1 m	43 1/2 in 1.1 m	43 1/2 in 1.1 m	NA
Length - operating	28 1/2 in 72.4 cm	28 1/2 in 72.4 cm	28 1/2 in 72.4 cm	NA
<b>Airborne noise emissions by machinery</b>				
Maximum sound level at normal operating workstations (A-weighted)				
<b>Manual winch</b>	90 dB	90 dB	90 dB	90 dB
<b>Electric winch</b>	95 dB	95 dB	95 dB	95 dB

\* The 10 inch pneumatic rear wheel option will add 1 inch / 2.5 cm to these specifications.

\* The 4 point caster option B will add 1 inch / 2.5 cm to these specifications.

\* The counterweight base will add 1 inch / 2.5 cm to these specifications.



SPECIFICATIONS

Model	GL-4	GL-8	GL-10	GL-12
<b>Forks</b>				
Length	22 <sup>1</sup> / <sub>2</sub> in 57.2 cm	22 <sup>1</sup> / <sub>2</sub> in 57.2 cm	22 <sup>1</sup> / <sub>2</sub> in 57.2 cm	22 <sup>1</sup> / <sub>2</sub> in 57.2 cm
Width	20 <sup>1</sup> / <sub>2</sub> in 52.1 cm	20 <sup>1</sup> / <sub>2</sub> in 52.1 cm	20 <sup>1</sup> / <sub>2</sub> in 52.1 cm	20 <sup>1</sup> / <sub>2</sub> in 52.1 cm
<b>Load Platform</b>				
Length	23 in 58.4 cm	23 in 58.4 cm	23 in 58.4 cm	23 in 58.4 cm
Width	22 in 55.9 cm	22 in 55.9 cm	22 in 55.9 cm	22 in 55.9 cm

**Machine Configurations**

**Base: Standard Base  
GL-4 and GL-8**

**\*Wheel and Casters:**

Pneumatic option  
 Front: 2<sup>1</sup>/<sub>2</sub> inch swivel casters  
 Rear: 10 inch pneumatic wheels

**Base: Straddle Base  
GL-4, GL-8, GL-10 and GL-12**

**\*Wheel and Casters:**

Pneumatic option  
 Front: 2<sup>1</sup>/<sub>2</sub> inch swivel casters  
 Rear: 10 inch pneumatic wheels

**4 point caster option A**

Front: 2 inch dual wheel swivel casters  
 Rear: 4 inch swivel casters

**4 point caster option B**

Front: 2<sup>1</sup>/<sub>2</sub> inch swivel casters  
 Rear: 5 inch swivel casters with side brakes and 4 point rotational locks

**Base: Counterweight  
GL-4, GL-8, GL-10**

**\*\*Wheel and Casters:**

Front: 4 inch fixed wheel  
 Rear: 5 inch swivel casters with side brakes

\*Machines with standard or straddle base ship standard with 8 inch rear wheels and 2 inch dual wheel front swivel casters.

\*\*Machines with counterweight base ship standard with 5 inch rear swivel casters with side brakes and 4 inch front fixed wheels.

**Machine Weights**

**Genie Lift 4**

Base:	Caster Option:	Weight:
Standard	Standard	113 lbs / 51 kg
Standard	Pneumatic	117 lbs / 53 kg
Straddle	Standard	126 lbs / 57 kg
Straddle	Pneumatic	130 lbs / 59 kg
Straddle	4 point caster A	137 lbs / 62 kg
Straddle	4 point caster B	139 lbs / 63 kg
Counterweight	Standard	392 lbs / 178 kg

**Genie Lift 8**

Base:	Caster Option:	Weight:
Standard	Standard	132 lbs / 60 kg
Standard	Pneumatic	136 lbs / 62 kg
Straddle	Standard	145 lbs / 66 kg
Straddle	Pneumatic	149 lbs / 68 kg
Straddle	4 point caster A	156 lbs / 71 kg
Straddle	4 point caster B	158 lbs / 72 kg
Counterweight	Standard	411 lbs / 186 kg

**Genie Lift 10**

Base:	Caster Option:	Weight:
Straddle	Standard	149 lbs / 68 kg
Straddle	Pneumatic	153 lbs / 69 kg
Straddle	4 point caster A	160 lbs / 73 kg
Straddle	4 point caster B	162 lbs / 73 kg
Counterweight	Standard	415 lbs / 188 kg

**Genie Lift 12**

Base:	Caster Option:	Weight:
Straddle	Standard	154 lbs / 70 kg
Straddle	Pneumatic	158 lbs / 72 kg
Straddle	4 point caster A	165 lbs / 75 kg
Straddle	4 point caster B	167 lbs / 76 kg

The electric winch option will add an additional 103 lbs / 47 kg to the above machine weights.